

# GAS SENSOR WITH CLOUD CONNECTION: OVERVIEW

Collecting environmental data has become more and more important for building, industrial and home applications, as it helps maintain a clean atmosphere and minimizes exposure to toxic and dangerous gases. Good air quality is also very important in factories to ensure a safe production site. This gas sensor solution monitors the existence of these gases and connects the data to the cloud.

Renesas' 32-bit RX130 MCU is connected to the sensor network by a smart Wi-Fi module to feed the data to a suitable gateway and then connects to the cloud.

## Key Features:

- Easy and fast to integrate
- Fast productization due to existing cloud solutions with AWS and an RX MCU
- Gas sensor with highest sensitivity to gases in the market

## Applications:

- Factory automation
- Building automation

# GAS SENSOR WITH CLOUD CONNECTION: BLOCK DIAGRAM

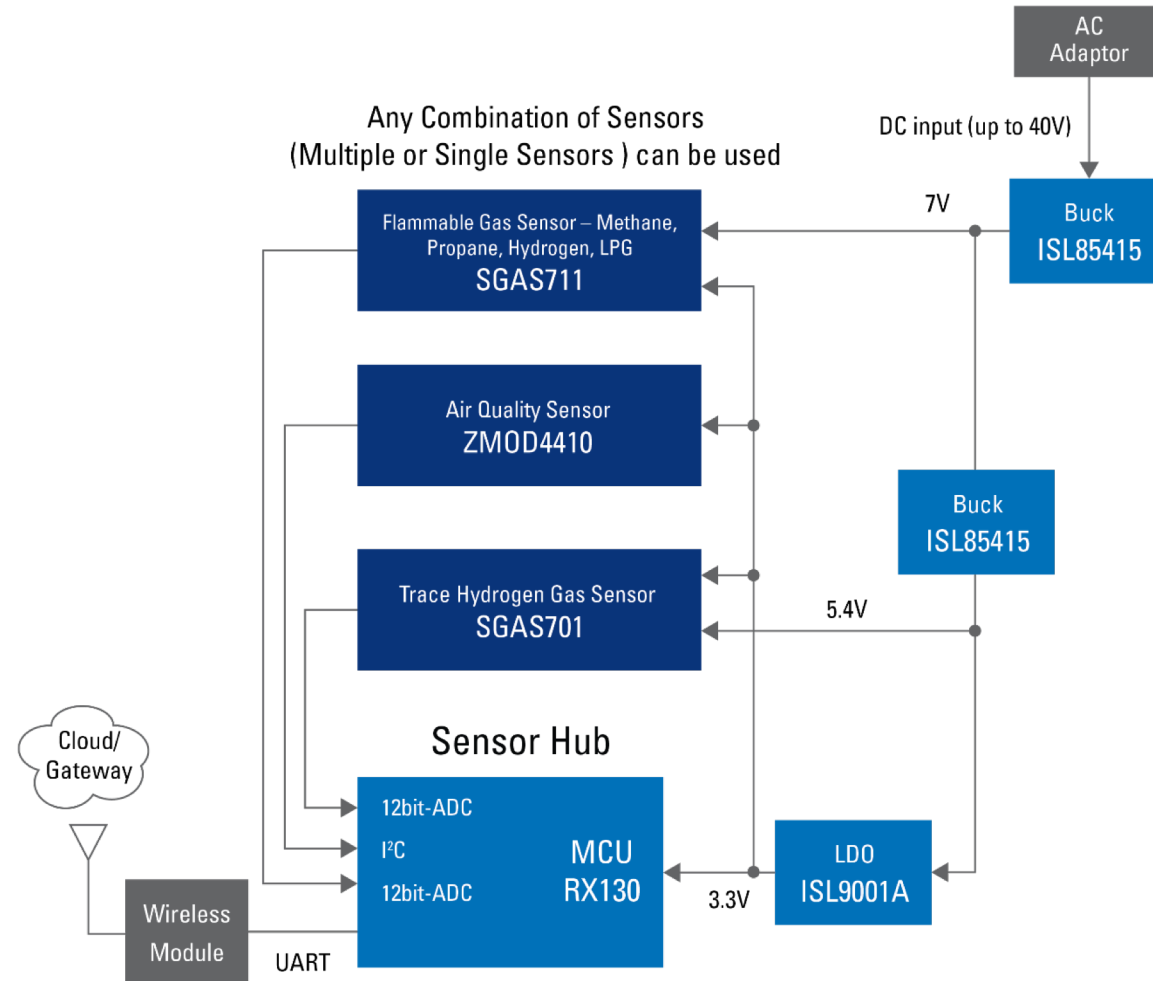

[Back to Directory](#)

# SGAS701: HIGH SENSITIVITY HYDROGEN GAS SENSOR

## A solid-state chemiresistor sensor

Features	Benefits	Applications
<ul style="list-style-type: none"><li>• High sensitivity to low hydrogen concentrations (10 to 1000 ppm)</li><li>• Fast response time (15 seconds at 100 ppm)</li><li>• Environmental temperature range of -20°C to 50°C</li><li>• Environmental humidity range of 0% to 90% RH, non-condensing</li><li>• Low dependence on flow rate</li></ul>	<ul style="list-style-type: none"><li>• The SGAS701 is a solid-state chemi-resistor sensor designed to detect hydrogen in air.</li><li>• The sensor uses an integrated heater with highly sensitive MOx material tailored for detection of hydrogen.</li><li>• Example of Target Gases:<ul style="list-style-type: none"><li>• Hydrogen H2</li></ul></li></ul>	<ul style="list-style-type: none"><li>• Leak Detection</li><li>• Gas Concentration Detection</li><li>• Breath Detection</li></ul>

## Typical application and key performances

The Renesas SGAS701 is a solid-state chemiresistor sensor designed to detect hydrogen in air. The sensor uses an integrated heater with highly sensitive MOx material tailored for detection of hydrogen.

Renesas has developed a set of nanostructured gas sensing materials with excellent sensitivity and stability.

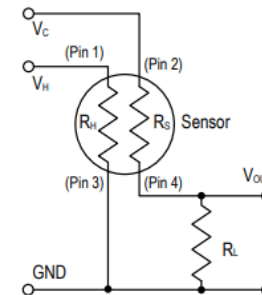

# ZMOD4410: GAS SENSOR MODULE TVOC

## Indoor Air Quality Sensor Platform

Features	Benefits	Applications
<ul style="list-style-type: none"> <li>• Proven MOx Material</li> <li>• Electrical and Gas calibrated</li> <li>• Flexible architecture with available GUI and firmware for different operation modes</li> <li>• Correlates German Committee on Indoor Guidelines (UBA study)</li> <li>• Miniature 3 x 3 x 0.7mm</li> <li>• Power consumption of &lt;1 mW in Low Power operation</li> <li>• Digital (I<sup>2</sup>C) output</li> <li>• Siloxane resistant</li> </ul>	<ul style="list-style-type: none"> <li>• Leading high sensitivity and long term stability</li> <li>• Calibrated sensor allows easy and fast system integration</li> <li>• Enables Customer to release product families via SW changes</li> <li>• International accepted definition of Indoor Air Quality (IAQ)</li> <li>• Calculation of estimated Carbon Dioxide (eCO<sub>2</sub>)</li> <li>• Reduced end product size</li> </ul>	<ul style="list-style-type: none"> <li>• HVAC Systems</li> <li>• Air Purifiers</li> <li>• Smart Thermostats</li> <li>• Smart Speakers</li> <li>• Bathroom fans</li> <li>• Kitchen exhaust hoods</li> <li>• Smart outlets &amp; receptacles</li> </ul>

## Best Performance in Stability and Sensitivity

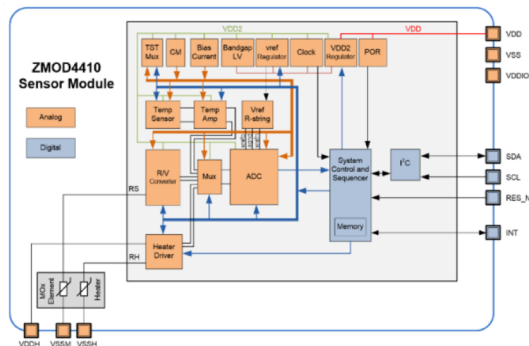

IDT IAQ Rating	Reference Level	Air Information	TVOC (mg/m <sup>3</sup> )	Air Quality
≤ 1.99	Level 1	Clean Hygienic Air (Target value)	< 0.3	Very Good
2.00 – 2.99	Level 2	Good Air Quality (if no threshold value is exceeded)	0.3 – 1.0	Good
3.00 – 3.99	Level 3	Noticeable Comfort Concerns (Not recommended for exposure > 12 months)	1.0 – 3.0	Medium
4.00 – 4.99	Level 4	Significant Comfort Issues (Not recommended for exposure > 1 month)	3.0 – 10.0	Poor
≥ 5.00	Level 5	Unacceptable Conditions (Not recommended)	> 10.0	Bad

# SGAS711: HIGH SENSITIVITY FLAMMABLE GAS SENSOR

*A solid-state chemiresistor sensor – Methane, Propane, Hydrogen, LPG*

Features	Benefits	Applications
<ul style="list-style-type: none"><li>• High sensitivity to a wide range of flammable gases,</li><li>• Non-specific response, calibration factors available upon request</li><li>• Typical response time &lt;1 minute to 90% full scale</li><li>• Environmental temperature of -20°C to 50°C</li><li>• Minimal response to environmental humidity over the range of 0% to 95%, non-condensing</li><li>• Rugged, reliable sensor based on IDT's exclusive technology</li></ul>	<ul style="list-style-type: none"><li>• The SGAS711 is a solid-state chemiresistor sensor designed to detect flammable gases in air.</li><li>• Integrated heater with highly sensitive MOx material tailored for detection of flammable gases.</li><li>• The device is ideal to be used as a methane gas sensor, propane gas sensor, hydrogen gas sensor, liquefied petroleum gas sensor (LPG sensor), and more</li></ul>	<ul style="list-style-type: none"><li>• Leak Detection</li><li>• Gas Concentration Detection</li><li>• Process Control</li></ul>

## Typical application and key performances

The Renesas SGAS711 is a solid-state chemiresistor sensor designed to detect flammable gases in air. The SGAS711 sensor uses an integrated heater with highly sensitive MOx material tailored for detection of flammable gases, such as methane, propane, hydrogen, liquefied petroleum gas (LPG), and more. In addition to detecting flammable gases, the sensor is also sensitive to other hydrocarbons, such as pentane and R410a, and it can be used for leak detection. Renesas has developed a set of nanostructured gas-sensing materials with excellent sensitivity and stability.

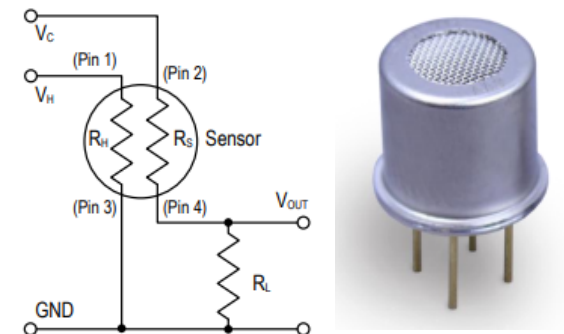

# RX130: HIGH PERFORMANCE MCU WITH TOUCH KEY FUNCTION

*Built-in functional safety hardware and can easily support the IEC/UL60730 safety standard*

Features	Benefits	Applications
<ul style="list-style-type: none"> <li>32-bit MCU @ 32MHz</li> <li>Operation from a single 1.8 V to 5.5 V</li> <li>Three low power mode                             <ul style="list-style-type: none"> <li>High Speed Mode : 96uA/MHz</li> <li>Software Standby Mode : 0.37uA</li> <li>Wakeup time from Standby Mode : 4.8uS</li> </ul> </li> <li>High sensitive 36pin(max.324 Key capacitive touch sensing unit.</li> <li>Useful functions for IEC60730 compliance</li> <li>Up to 512KB Flash and 48B RAM</li> <li>48pin, 52pin and 64pin LQFP packages</li> </ul>	<ul style="list-style-type: none"> <li>The RX130 Group integrates a built-in max. 36-channel capacitive touch sensor. The capacitive touch sensor uses an improved detection method compared to previous products and so has vastly improved noise immunity, sensitivity and water resistance.</li> </ul>	<ul style="list-style-type: none"> <li>Healthcare</li> <li>Home Appliance</li> <li>Human Machine Interface</li> <li>Industrial Sensor</li> <li>Capacitive Touch Control UI</li> </ul>

## Typical application and key performances

32-MHz, 32-bit RX MCUs, 50 DMIPS, up to 512-KB flash memory, up to 36 pins capacitive touch sensing unit, up to 6 comms channels, 12-bit A/D, D/A, RTC, IEC60730 compliance, 1.8-V to 5.5-V single supply

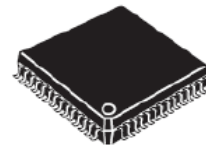

PLQP0100KB-B 14 × 14mm, 0.5mm pitch  
 PLQP0080KB-B 12 × 12mm, 0.5mm pitch  
 PLQP0064GA-A 14 × 14mm, 0.8mm pitch  
 PLQP0064KB-C 10 × 10mm, 0.5mm pitch  
 PLQP0048KB-B 7 × 7mm, 0.5mm pitch



PWQN0048KB-A 7 × 7mm, 0.5mm pitch

# ISL85415: WIDE VIN 500MA SYNCHRONOUS BUCK REGULATOR

## Selectable PFM or PWM mode operation

Features	Benefits	Applications
<ul style="list-style-type: none"> <li>• Synchronous Operation for high efficiency</li> <li>• No compensation required</li> <li>• Selectable PFM or forced PWM mode at light loads</li> <li>• Internal fixed (500kHz) or adjustable Switching frequency 300kHz to 2MHz</li> <li>• Internal or external soft-start</li> <li>• Minimal external components required</li> <li>• Power-good and enable functions available</li> </ul>	<ul style="list-style-type: none"> <li>• It provides an easy to use, high efficiency low BOM count solution for a variety of applications.</li> <li>• It will provide a very robust design for high voltage Industrial applications as well as an efficient solution for battery powered applications</li> </ul>	<ul style="list-style-type: none"> <li>• Industrial control</li> <li>• Medical devices</li> <li>• Portable instrumentation</li> <li>• Distributed Power supplies</li> <li>• Cloud Infrastructure</li> </ul>

## Typical application and key performances

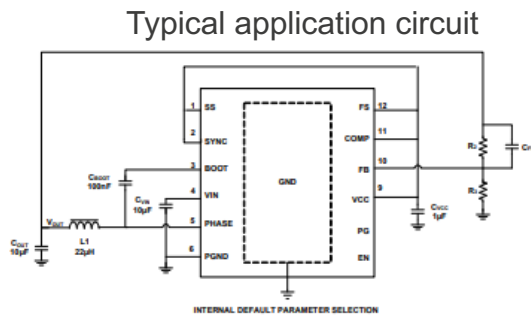

FIGURE 1. TYPICAL APPLICATION

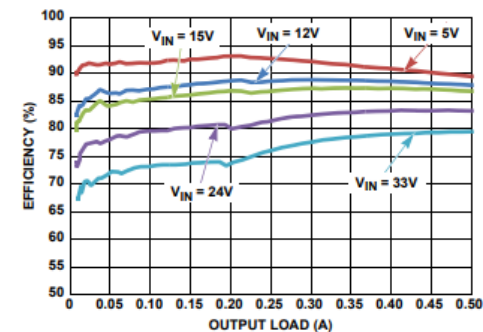

FIGURE 2. EFFICIENCY vs LOAD, PFM, V<sub>OUT</sub> = 3.3V

# ISL9001A: HIGH ACCURACY HIGH PSRR LDO IN TINY PACKAGE

*Low dropout regulator with low Iq and high PSRR*

Features	Benefits	Applications
<ul style="list-style-type: none"> <li>• Excellent transient response to large current steps</li> <li>• Excellent load regulation: &lt;0.1% voltage change across full range of load current</li> <li>• High PSRR: 90dB @ 1kHz</li> <li>• Extremely low quiescent current: 25µA</li> <li>• Low dropout voltage: typically 200mV @ 300mA</li> <li>• Low output noise: typically 30µVRMS @ 100µA (1.5V)</li> </ul>	<ul style="list-style-type: none"> <li>• When coupled with a no load quiescent current of 25µA (typical), and 0.1µA shutdown current, the ISL9001A is an ideal choice for low power consumption application.</li> </ul>	<ul style="list-style-type: none"> <li>• PDAs, cell phones and smart phones</li> <li>• Portable instruments, MP3 players</li> <li>• Handheld devices, including medical handhelds</li> </ul>

## Typical application and key performances

Typical application circuit

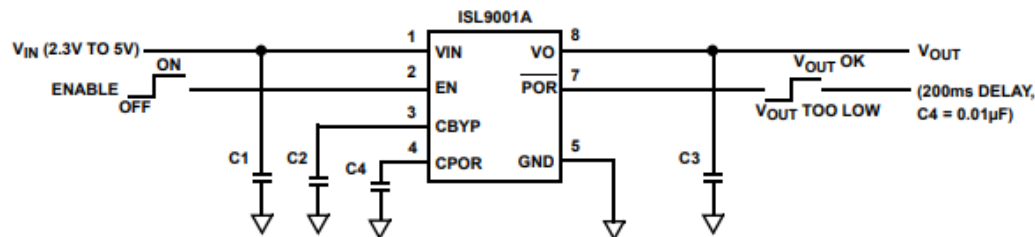

ISL9001A  
(8 LD DFN)  
TOP VIEW

