



dsPIC33FJ06GS101/X02 and dsPIC33FJ16GSX02/X04

dsPIC33FJ06GS101/X02 and dsPIC33FJ16GSX02/X04 Family Silicon Errata and Data Sheet Clarification

The dsPIC33FJ06GS101/X02 and dsPIC33FJ16GSX02/X04 family devices that you have received conform functionally to the current Device Data Sheet (DS70000318G), except for the anomalies described in this document.

The silicon issues discussed in the following pages are for silicon revisions with the Device and Revision IDs listed in [Table 1](#). The silicon issues are summarized in [Table 2](#).

The errata described in this document will be addressed in future revisions of the dsPIC33FJ06GS101/X02 and dsPIC33FJ16GSX02/X04 silicon.

Note: This document summarizes all silicon errata issues from all revisions of silicon, previous as well as current. Only the issues indicated in the last column of [Table 2](#) apply to the current silicon revision (**A4**).

Data Sheet clarifications and corrections start on [page 19](#), following the discussion of silicon issues.

The silicon revision level can be identified using the current version of MPLAB® IDE and Microchip's programmers, debuggers and emulation tools, which are available at the Microchip corporate web site (www.microchip.com).

For example, to identify the silicon revision level using MPLAB IDE in conjunction with a hardware debugger:

1. Using the appropriate interface, connect the device to the hardware debugger.
2. Open an MPLAB IDE project.
3. Configure the MPLAB IDE project for the appropriate device and hardware debugger.
4. Based on the version of MPLAB IDE you are using, do one of the following:
 - a) For MPLAB IDE 8, select *Programmer > Reconnect*.
 - b) For MPLAB X IDE, select *Window > Dashboard* and click the **Refresh Debug Tool Status** icon ().
5. Depending on the development tool used, the part number and Device ID and Revision ID values appear in the **Output** window.

Note: If you are unable to extract the silicon revision level, please contact your local Microchip sales office for assistance.

The Device and Revision ID values for the various dsPIC33FJ06GS101/X02 and dsPIC33FJ16GSX02/X04 silicon revisions are shown in [Table 1](#).

TABLE 1: SILICON DEVREV VALUES

Part Number	Device ID ⁽¹⁾	Revision ID for Silicon Revision ⁽²⁾		
		A2	A3	A4
dsPIC33FJ06GS101	0x0C00	0x3002	0x3003	0x3004
dsPIC33FJ06GS102	0x0C01			
dsPIC33FJ06GS202	0x0C02			
dsPIC33FJ16GS402	0x0C04			
dsPIC33FJ16GS404	0x0C06			
dsPIC33FJ16GS502	0x0C03			
dsPIC33FJ16GS504	0x0C05			

- Note 1:** The Device and Revision IDs (DEVID and DEVREV) are located at the last two implemented addresses in program memory.
- 2:** Refer to the “dsPIC33F/PIC24H Flash Programming Specification” (DS70152) for detailed information on Device and Revision IDs for your specific device.

dsPIC33FJ06GS101/X02 and dsPIC33FJ16GSX02/X04

TABLE 2: SILICON ISSUE SUMMARY

Module	Feature	Item Number	Issue Summary	Affected Revisions ⁽¹⁾		
				A2	A3	A4
PWM	Leading-Edge Blanking	1.	Reading LEBCONx registers, as well as writing individual bits and bytes within these registers, does not work.	X	X	X
PWM	Immediate Updates	2.	PWM Immediate Update mode (IEU = 1) for the Master Duty Cycle register (MDC) is not functional.	X	X	X
PWM	Status Bits	3.	PWM Fault Status bits do not function if the associated PWM Fault interrupts are disabled.	X	X	X
PWM	Clock	4.	PWM output will exhibit jitter with some PWM clock divider settings.	X	X	X
PWM	Faults	5.	If the PWM is in Complementary, Redundant and Push-Pull mode and the Independent Time Base bit (ITB) is set, the Independent Fault mode may not work as expected for the PWMxL pin.	X	X	X
PWM	Independent Time Base	6.	The Independent Time Base PWM outputs may not be synchronized with the Master time base PWM outputs when both modes are used simultaneously.	X	X	X
PWM	Latched Faults	7.	In PWM Latched Fault mode, the PWM outputs may be latched on both the rising as well as the falling edge of the Fault signal regardless of the Fault input polarity selection (set with the FCLCONx<FLTPOL> bit setting).	X	X	X
PWM	Faults	8.	A bit write to the CLMOD bit (bit 8) in the FCLCONx register, or consecutive writes to the lower byte and higher byte of the FCLCONx register, causes all other bits of the high byte to be loaded with zeros.	X	X	X
PWM	Sleep Mode	9.	The PWM module fails to wake the CPU from Sleep mode on a PWM Fault event.	X	X	X
Comparator	—	10.	For slow input signals, the Comparator module may generate erroneous triggers/interrupts.	X	X	X
ADC	Clock	11.	Selecting the primary FRC (Fvco) as a clock source for the ADC module by setting the SLOWCLK bit (ADCON<12>) to the default setting of '0', does not work.	X	X	X
Auxiliary Clock	Module Disable	12.	When the PWMMD bit in the PMD1 register is set, the Auxiliary Clock to both the ADC and PWM modules is disabled.	X	X	X
Comparator	Interrupts	13.	Comparator interrupts are incorrectly generated when the High-Speed Analog Comparator is configured for an inverted polarity setting (CMPCONx<CMPPOL> = 1).	X	X	X
UART	4x Mode	14.	When the UART is in 4x mode (BRGH = 1) and using two Stop bits (STSEL = 1), it may sample the first Stop bit instead of the second one.	X	X	X
UART	IR Interface Operations	15.	The 16x baud clock signal on the BCLK pin is present only when the module is transmitting.	X	X	X
I ² C™	10-Bit Addressing Mode	16.	When the I ² C™ module is configured for 10-bit addressing using the same address bits (A10 and A9) as other I ² C devices, the A10 and A9 bits may not work as expected.	X	X	X
PWM	ADC Conversion	17.	The PWM module may fail to trigger a conversion on certain ADC pairs when the primary or secondary PWMx generator is selected as a trigger source.	X		

Note 1: Only those issues indicated in the last column apply to the current silicon revision.

dsPIC33FJ06GS101/X02 and dsPIC33FJ16GSX02/X04

TABLE 2: SILICON ISSUE SUMMARY (CONTINUED)

Module	Feature	Item Number	Issue Summary	Affected Revisions ⁽¹⁾		
				A2	A3	A4
Core	PGEC3/ PGED3 Programming Pins	18.	When using the PGEC3/PGED3 pins for device programming, the programming time may be slower as compared to other available PGECx/PGEDx pin pairs.	X	X	X
UART	Break Character Generation	19.	The UART module will not generate back-to-back Break characters.	X	X	X
PWM	Current Limit	20.	Cycle-by-cycle current-limit operation does not work when the PWM module is configured for Center-Aligned mode.	X	X	X
PWM	Current Reset Mode	21.	Current Reset mode does not work when the current-limit source (CLSRC) occurs during, and persists past, the assertive time interval of the PWM, and leading-edge blanking time is less than the PWM assertive time interval.	X	X	X
UART	IrDA [®] Encoder/ Decoder (8-bit Mode)	22.	When the UART module is operating in 8-bit mode (PDSEL = 0x) and using the IrDA encoder/decoder (IREN = 1), the module incorrectly transmits a data payload of 80h as 00h.	X	X	X
UART	UxE Interrupt	23.	The UART error interrupt may not occur, or may occur at an incorrect time, if multiple errors occur during a short period of time.	X	X	X
I ² C	10-Bit Addressing Mode	24.	When the I ² C™ module is configured as a 10-bit slave with an address of 0x102, the I2CxRCV register content for the lower address byte is 0x01 rather than 0x02.	X	X	X
I ² C	10-Bit Addressing Mode	25.	The 10-bit slave does not set the RBF flag or load the I2CxRCV register, on address match if the Least Significant bits (LSBs) of the address are the same as the 7-bit reserved addresses.	X	X	X
PSV Operations	Addressing Modes	26.	An address error trap occurs in certain addressing modes when accessing the first four bytes of any PSV page.	X	X	X
Comparator	Sleep Mode	27.	The Comparator fails to wake the CPU from Sleep mode when the internal voltage reference is used.	X	X	X
PWM	Independent Time Base	28.	When updating the frequency on the fly, push-pull PWM outputs may not be synchronized with other PWM output modes.	X	X	X
Analog Comparator	Internal Band Gap Reference Voltage	29.	The Internal Band Gap Reference Voltage (INTREF) for the analog comparator does not meet the stated accuracy specifications.	X	X	X
Auxiliary PLL	Input Frequency	30.	For extended temperature devices, the auxiliary PLL input frequency does not meet the published specification range.	X	X	X
ADC	Current Consumption in Sleep Mode	31.	If the ADC module is in an enabled state when the device enters Sleep mode, the power-down current (IPD) of the device may exceed the device data sheet specifications.	X	X	X
High-Speed PWM	PWM Module Enable	32.	A glitch may be observed on the PWM pins when the PWM module is enabled after assignment of pin ownership to the PWM module.	X	X	X
Reserved	—	33.	—	—	—	—

Note 1: Only those issues indicated in the last column apply to the current silicon revision.

dsPIC33FJ06GS101/X02 and dsPIC33FJ16GSX02/X04

TABLE 2: SILICON ISSUE SUMMARY (CONTINUED)

Module	Feature	Item Number	Issue Summary	Affected Revisions ⁽¹⁾		
				A2	A3	A4
PWM	Duty Cycle Updates	34.	When the PWM duty cycle update coincides with the PWM period rollover, the PWM output may be corrupted for one PWM period.	X	X	X
JTAG	Active Pull-up	35.	In JTAG mode, the TMS pin will not have an active pull-up as required by the JTAG specification.	X	X	X
SPI	Framed Master Mode	36.	When the SPI module is configured in Framed Master mode and the Frame Sync Pulse Edge Select bit (FRMDLY) is set to '1', transmitting a word and then buffering another word in the SPIxBUF register before the transmission has completed, results in an incomplete transmission of the first data word.	X	X	X
Comparator	Trigger Voltage Level	37.	Output signal transitions occurring on the DACOUT pin (with DAC output disabled) can cause the Comparator trigger voltage level to change.	X	X	X
CPU	Interrupt Disable	38.	When a previous DISI instruction is active (i.e., the DISICNT register is non-zero), and the value of the DISICNT register is updated manually, the DISICNT register freezes and disables interrupts permanently.	X	X	X
CPU	div.sd	39.	When using the div.sd instruction, the overflow bit is not getting set when an overflow occurs.	X	X	X
UART	TX Interrupt	40.	A Transmit (TX) interrupt may occur before the data transmission is complete.	X	X	X
JTAG	Flash Programming	41.	JTAG Flash programming is not supported.	X	X	X
PWM	PWM Module Enable	42.	If the PWM Clock Divider Select register, PTCON2, is not equal to zero, the PWM module may or may not initialize from an override state	X	X	X
PWM	PWM SWAP	43.	If the PWM is configured for Complimentary mode and the SWAP bit is enabled, the PWM outputs might operate as Redundant mode when the PHASE value is greater than the programmed dead-time (DTRx) value.	X	X	X
PWM	Current-Limit Mode	44.	A < 8-ns glitch may be observed on the PWM output pins when the Current-Limit event occurs.	X	X	X
PWM	Immediate Update	45.	Dead time is not asserted when PDCx is updated to cause an immediate transition on the PWMxH and PWMxL outputs.	X	X	X
ADC	—	46.	ADC measurement of INTREF may be zero under certain start-up conditions.	X	X	X
PWM	Redundant/ Push-Pull Output Mode	47.	When the Immediate Update is disabled, changing the duty cycle value from a non-zero value to zero will produce a glitch pulse equal to 1 PWM clock.	X	X	X
PWM	Master Time Base Mode	48.	When the Immediate Update is disabled, certain changes to the PHASEx register may result in missing dead time.	X	X	X
PWM	Trigger Compare Match	49.	First PWM/ADC trigger event on TRIGx/STRIGx match may not occur under certain conditions.	X	X	X
I ² C	Slave Mode	50.	Clock stretching may not occur when enabled.	X	X	X

Note 1: Only those issues indicated in the last column apply to the current silicon revision.

dsPIC33FJ06GS101/X02 and dsPIC33FJ16GSX02/X04

Silicon Errata Issues

Note: This document summarizes all silicon errata issues from all revisions of silicon, previous as well as current. Only the issues indicated by the shaded column in the following tables apply to the current silicon revision (**A4**).

1. Module: PWM

Reading LEBCONx registers, as well as writing individual bits and bytes within these registers does not work.

Work around

Use a Word write operation to modify LEBCONx registers. For example, to set the PHR bit within the LEBCON1 register, use the following C code:

```
LEBCON1 = 0x8000
```

There is no work around for reading LEBCONx registers.

Affected Silicon Revisions

A2	A3	A4					
X	X	X					

2. Module: PWM

If PWM Immediate Update mode is selected (IUE = 1), and the PWM duty cycle is provided via the Master Duty Cycle (MDC) register (MDCS = 1 mode), the updates to the MDC register are synchronized to the PWM time base instead of an immediate update (duty cycle will be updated on the next PWM period).

Work arounds

Work around 1:

Use the Enable Immediate Period Update mode (EIPU = 1) in conjunction with PWM Immediate Update mode (IUE = 1). This will update the period and duty cycle on an immediate basis.

Work around 2:

Use individual duty cycle registers (PDCx) and PWM Immediate Update mode (IUE = 1) to update individual duty cycle registers on an immediate basis.

Affected Silicon Revisions

A2	A3	A4					
X	X	X					

3. Module: PWM

If PWM Fault interrupts are disabled (FLTIEEN = 0 or CLIEEN = 0), then associated Status bits (FLTSTAT and CLSTAT) will not function.

Work around

Enable PWM Fault interrupts (FLTIEEN = 1, CLIEEN = 1).

Affected Silicon Revisions

A2	A3	A4					
X	X	X					

4. Module: PWM

The PWM output will exhibit jitter under the following conditions:

When the PWM clock divider has the value of 1, 5 or 6 (PTCON2<PCLKDIV> = 0b001, 0b101 or 0b110), and the three Least Significant bits of the PWM Period Register (PTPER or PHASEx), Duty Cycle Register (MDC or PDCx) or Phase Register (PHASEx) are non-zero.

Work around

Use PWM clock dividers other than 1, 5 or 6.

Affected Silicon Revisions

A2	A3	A4					
X	X	X					

dsPIC33FJ06GS101/X02 and dsPIC33FJ16GSX02/X04

5. Module: PWM

When PWM module is operated in Complementary, Redundant and Push-pull output modes, with Independent Time Base (ITB = 1) and Independent Fault mode (IFLTMOD = 1) enabled, the PWMxH and PWMxL outputs should be affected by the Fault and Current-Limit events as follows:

- PWMxH is affected by Current-Limit source (FCLCON<CLSRC>) and the Current-Limit should be reset at the end of the primary local time base.
- PWMxL is affected by Fault source (FCLCON<FLTSRC>) and the Fault should be reset at the end of the primary local time base.

On silicon revisions affected by this erratum, the Current-Limit event works correctly for the PWMxH pin. However, the Fault event is reset by the secondary local time base although it is not used to generate the time base value. As a result, the Fault event on PWMxL pin may not work as expected. This erratum only applies to the cycle-by-cycle Fault mode (FLTMOD = 0b01).

Work around

If PWM is in Complementary, Redundant or Push-Pull mode and (ITB = 1), set SPHASEx to have the same value as PHASEx. This will ensure that the Fault event on the PWMxL pin is reset at the start of the new PWM period for cycle-by-cycle independent Fault operation.

Affected Silicon Revisions

A2	A3	A4					
X	X	X					

6. Module: PWM

The independent time base PWM outputs may not be synchronized with the Master time base PWM outputs when both modes are used simultaneously.

Work around

To synchronize the Independent PWM outputs with the Master time base PWM outputs, disable the Immediate Update Enable bit (IUE = 0), ensure that the three Least Significant bits of the period are zero, and that the duty cycle is between 8 ns and the period minus 0x8.

This work around will not work if the frequency of the PWM module is being updated on the fly.

Affected Silicon Revisions

A2	A3	A4					
X	X	X					

7. Module: PWM

In PWM Latched Fault mode, the PWM outputs may be latched on both the rising as well as the falling edge of the Fault signal, regardless of the Fault input polarity selection (set with the FCLCONx<FLTPOL> bit setting).

Work around

None.

Affected Silicon Revisions

A2	A3	A4					
X	X	X					

8. Module: PWM

A bit write to the CLMOD bit (bit 8) in the FCLCONx register or consecutive writes to the lower byte and higher byte of the FCLCONx register, causes all other bits of the high byte to be loaded with zeros.

Work around

Use Word writes for the FCLCONx register instead of bit or byte writes.

Affected Silicon Revisions

A2	A3	A4					
X	X	X					

dsPIC33FJ06GS101/X02 and dsPIC33FJ16GSX02/X04

9. Module: PWM

The PWM module fails to wake the CPU from Sleep mode on a PWM Fault event.

Work around

Use the external interrupt pins to wake the CPU from Sleep mode.

Affected Silicon Revisions

A2	A3	A4						
X	X	X						

10. Module: Comparator

If the slew rate of the Comparator input signal is lower than 198 mV/μs, the Comparator module generates erroneous triggers/interrupts.

Work around

The Slew rate of Comparator input signal must be higher than 198 mV/μs to avoid multiple triggers/interrupts.

Affected Silicon Revisions

A2	A3	A4						
X	X	X						

11. Module: ADC

Selecting the primary FRC (Fvco) as a clock source for the ADC module by setting the SLOWCLK bit (ADCON<12>) to the default setting of '0', does not work.

Work around

Always set the SLOWCLK bit (ADCON<12>) to '1', which selects the Auxiliary Clock (ACLK) as a clock source for the ADC. Use the Auxiliary Clock Configuration registers to select the primary FRC (Fvco) as a source (if desired) or other clock sources as inputs. See **Section 8.0 "Oscillator Configuration"** of the device data sheet (DS70000318G) for more information.

Affected Silicon Revisions

A2	A3	A4						
X	X	X						

12. Module: Auxiliary Clock

When the PWMMD bit in the PMD1 register is set, the Auxiliary Clock to both the ADC and PWM modules is disabled.

Work around

To disable the Auxiliary clock for the PWM module but not for the ADC module, set the individual PWM generator PMD bits in the PMD6 register.

Affected Silicon Revisions

A2	A3	A4						
X	X	X						

13. Module: Comparator

The comparator interrupt should be generated on a rising edge of the comparator output. When using the inverted polarity setting for the analog comparator (CMPCONx<CMPPOL> = 1), the interrupt should be generated when the analog voltage at the comparator input falls below the programmable threshold determined by the CMPDAC register setting. However, with this setting the interrupts may be generated regardless of the state of the comparator.

Work around

When using comparator interrupts, configure the external circuit to use the non-inverted polarity comparator setting (CMPCONx<CMPPOL> = 0).

Affected Silicon Revisions

A2	A3	A4						
X	X	X						

14. Module: UART

When the UART is in 4x mode (BRGH = 1) and using two Stop bits (STSEL = 1), it may sample the first Stop bit instead of the second one.

This issue does not affect the other UART configurations.

Work around

Use the 16x baud rate option (BRGH = 0) and adjust the baud rate accordingly.

Affected Silicon Revisions

A2	A3	A4						
X	X	X						

dsPIC33FJ06GS101/X02 and dsPIC33FJ16GSX02/X04

15. Module: UART

When the UART is configured for IR interface operations (UxMODE<9:8> = 11), the 16x baud clock signal on the BCLK pin is present only when the module is transmitting. The pin is idle at all other times.

Work around

Configure one of the output compare modules to generate the required baud clock signal when the UART is receiving data or in an Idle state.

Affected Silicon Revisions

A2	A3	A4						
X	X	X						

16. Module: I²C™

If there are two I²C devices on the bus, one of them is acting as the Master receiver and the other as the Slave transmitter. If both devices are configured for 10-bit addressing mode, and have the same value in the A10 and A9 bits of their addresses, then when the Slave select address is sent from the Master, both the Master and Slave Acknowledge it. When the Master sends out the read operation, both the Master and the Slave enter into Read mode and both of them transmit the data. The resultant data will be the ANDing of the two transmissions.

Work around

In all I²C devices, the addresses, as well as bits A10 and A9, should be different.

Affected Silicon Revisions

A2	A3	A4						
X	X	X						

EXAMPLE 1: USING DUAL TRIGGER MODE

```
TRGCON1bits.DTM = 1;          /* Dual trigger mode (DTM) and STRIG used in combination to generate */
                               /* ADCPx triggers */
TRIG1 = 1224;                 /* Configure desired trigger */
STRIG1 = 1232;                /* STRIG1 should be configured for TRIG1 + 8 */
ADCPC2bits.TRGSRC5 = 0x4;    /* PWM1 primary trigger selected as ADC trigger source for ADCP5*/
```

17. Module: PWM

When the primary or secondary PWMx generator is selected as a trigger source for ADC convert pairs 3, 4, 5 or 6 and the PWM module is running at the maximum speed, the PWM module may fail to trigger a conversion on these ADC pairs.

Work arounds

Work around 1:

Configure the PWM module to trigger the ADC module per the following steps (see [Example 1](#) for the code used in this work around):

1. Enable the dual trigger mode bit (DTM) in the TRGCONx register.
2. Configure the TRIGx register to the desired trigger point.
3. Configure the STRIGx register to TRIGx + 0x8.
4. Select the PWMx primary trigger as the ADC trigger source for conversion.

If the PWM channel is configured for independent output mode and both channels are operating on the same time base, the phase difference between the two channels must be considered when setting the STRIGx register. This work around will not work for True Independent Time Base mode.

With this work around, the PWMx secondary trigger should not be selected as the trigger source for the ADC convert pair.

Work around 2:

Configure the PWM Input Clock Prescaler bits (PCLKDIV) for divide by 2 or higher.

Work around 3:

Utilize other available trigger sources, such as software or timer triggers, to initiate conversion on the affected ADC convert pairs.

Affected Silicon Revisions

A2	A3	A4						
X								

dsPIC33FJ06GS101/X02 and dsPIC33FJ16GSX02/X04

18. Module: Core

When using the PGEC3/PGED3 pins for device programming, the programming time may be slower as compared to other available PGECx/PGEDx pin pairs, because the Enhanced ICSP™ programming algorithm cannot be executed on this pin pair.

Refer to the “dsPIC33F/PIC24H Flash Programming Specification” (DS70152) for additional information on this limitation.

Work around

Use alternate PGECx/PGEDx programming pin pairs.

Affected Silicon Revisions

A2	A3	A4					
X	X	X					

19. Module: UART

The UART module will not generate consecutive Break characters. Trying to perform a back-to-back Break character transmission will cause the UART module to transmit the dummy character used to generate the first Break character instead of transmitting the second Break character. Break characters are generated correctly if they are followed by non-Break character transmission.

Work around

None.

Affected Silicon Revisions

A2	A3	A4					
X	X	X					

20. Module: PWM

Cycle-by-cycle current-limit operation does not work when the PWM module is configured for Center-Aligned mode.

Work around

None.

Affected Silicon Revisions

A2	A3	A4					
X	X	X					

21. Module: PWM

During normal operation, if Leading-Edge Blanking (LEB) is triggered to start counting at a rising edge of PWM and the PWM module has a blanking time period less than the PWM assertive time (TON time), and the current-limit event occurs during the TON period and is still pending after the TON period is over, the current-limit event should be ignored during TON time, but should be recognized after the TON time is over.

However, the device fails to recognize the current-limit event after TON time is over, when previously described conditions exist.

Work around

Initialize the LEBCONx register as shown below, which specifies the LEB function for the (CLSRC) input to be triggered on the falling (trailing) edge of PWM, and set the LEB delay to a minimum value of 8 ns:

- PHF bit is set
- CLLEBEN bit is set
- LEB<9:3> bits are set to a minimum value of '1'

If the user application needs LEB to be triggered at a falling edge, make sure that the LEB delay is set for more than the TON time.

Affected Silicon Revisions

A2	A3	A4					
X	X	X					

22. Module: UART

When the UART is operating in 8-bit mode (PDSEL<1:0> = 0x) and using the IrDA® encoder/decoder (IREN = 1), the module incorrectly transmits a data payload of 80h as 00h.

Work around

None.

Affected Silicon Revisions

A2	A3	A4					
X	X	X					

dsPIC33FJ06GS101/X02 and dsPIC33FJ16GSX02/X04

23. Module: UART

The UART error interrupt may not occur, or may occur at an incorrect time, if multiple errors occur during a short period of time.

Work around

Read the error flags in the UxSTA register whenever a byte is received to verify the error status. In most cases, these bits will be correct, even if the UART error interrupt fails to occur.

Affected Silicon Revisions

A2	A3	A4					
X	X	X					

24. Module: I²C

When the I²C module is configured as a 10-bit slave with an address of 0x102, the I2CxRCV register content for the lower address byte is 0x01, rather than 0x02; however, the module Acknowledges both address bytes.

Work around

None.

Affected Silicon Revisions

A2	A3	A4					
X	X	X					

25. Module: I²C

In 10-Bit Addressing mode, some address matches do not set the RBF flag or load the I2Cx Receive register, I2CxRCV, if the lower address byte matches the reserved addresses. In particular, these include all addresses with the form, 'xx0000xx' and 'xx1111xxxx', with the following exceptions:

- '001111000x'
- '011111001x'
- '101111010x'
- '111111011x'

Work around

Ensure that the lower address byte in 10-Bit Addressing mode does not match any 7-bit reserved addresses.

Affected Silicon Revisions

A2	A3	A4					
X	X	X					

26. Module: PSV Operations

An address error trap occurs in certain addressing modes when accessing the first four bytes of an PSV page. This occurs only when using the following addressing modes:

- MOV.D
- Register Indirect Addressing (Word or Byte mode) with pre/post-decrement

Work around

Do not perform PSV accesses to any of the first four bytes using the above addressing modes. For applications using the C language, MPLAB[®] C30 Version 3.11 or higher, provides the following command-line switch that implements a work around for the erratum.

```
-merrata=psv_trap
```

Refer to the `readme.txt` file in the MPLAB C30 v3.11 toolsuite for further details.

Affected Silicon Revisions

A2	A3	A4					
X	X	X					

27. Module: Comparator

The comparator fails to wake the CPU from Sleep mode when the internal voltage reference is used (i.e., the EXTREF bit is set to '0').

Work around

Use the external reference source by setting the EXTREF bit to '1'.

Affected Silicon Revisions

A2	A3	A4					
X	X	X					

28. Module: PWM

When multiple PWM channels are operating in Independent Time Base mode (ITB = 1) and the frequency is being updated on the fly, PWM channels configured for Push-Pull mode may not remain synchronized with other PWM output modes.

Work around

When multiple PWM channels are operating in Independent Time Base mode, immediate updates to the PWM module (IUE = 1) must be enabled for PWM channels to remain synchronized.

Affected Silicon Revisions

A2	A3	A4					
X	X	X					

dsPIC33FJ06GS101/X02 and dsPIC33FJ16GSX02/X04

29. Module: Analog Comparator

The Internal Band Gap Reference Voltage (INTREF) for the analog comparator provides the reference to the analog comparator if the EXTREF bit (CMPCONx<5>) = 0 and the RANGE bit (CMPCONx<0>) = 0. The data sheet states that the INTREF voltage should be 1.2V nominal and within $\pm 1\%$.

However, the internal band gap reference voltage does not meet the specification stated above. For the actual range of the INTREF voltage, refer to the IVREF specification in the “**Electrical Characteristics**” chapter of the device data sheet.

Work arounds

To avoid this issue, implement one of the following two work arounds, depending on the application requirements.

Work around 1:

Use an external voltage reference for the Analog Comparator by setting the EXTREF bit (CMPCONx<5>) = 1 and providing an external reference to the EXTREF pin.

Work around 2:

Use the high-range setting for the internal reference by setting the EXTREF bit (CMPCONx<5>) = 0 and the RANGE bit (CMPCONx<0>) = 1. This setting uses $AV_{DD}/2$ as the comparator reference voltage.

Affected Silicon Revisions

A2	A3	A4					
X	X	X					

30. Module: Auxiliary PLL

For extended temperature devices (designated with the -E suffix in the device part number) with the date code of 09XX, the auxiliary PLL input frequency does not meet the published specification range at operating temperatures above +85°C.

Work around

Use the internal FRC oscillator as the input to the auxiliary PLL, or use the external oscillator with a frequency of 7.37 MHz.

Affected Silicon Revisions

A2	A3	A4					
X	X	X					

dsPIC33FJ06GS101/X02 and dsPIC33FJ16GSX02/X04

31. Module: ADC

If the ADC module is in an enabled state when the device enters Sleep mode as a result of executing a `PWRSVAV #0` instruction, the device power-down current (IPD) may exceed the specifications listed in the device data sheet. This may happen even if the ADC module is disabled by clearing the ADON bit prior to entering Sleep mode.

Work arounds

Work around 1:

In order to remain within the IPD specifications listed in the device data sheet, the user software must completely disable the ADC module by setting the ADC Module Disable bit in the corresponding Peripheral Module Disable x register (PMDx), prior to executing a `PWRSVAV #0` instruction.

Note: The ADC module must be reinitialized by the user application before resuming ADC operation.

Work around 2:

If the ADC module was previously initialized and enabled, before entering Sleep, execute the lines of code provided in [Example 2](#).

Note: Unlike **Work around 1**, the user application does not need to reinitialize the ADC module; however, it is necessary to re-enable the ADC module by setting the ADON bit after waking from Sleep.

EXAMPLE 2:

```
AD1CON1bits.ADON = 0;           //Disable the ADC module
__asm__ volatile ("REPEAT #50"); //Wait 50 Tcy
__asm__ volatile ("NOP");       //Repeat NOP 51 times
Sleep();                        // Execute PWRSVAV #0 and go to Sleep
```

Affected Silicon Revisions

A2	A3	A4						
X	X	X						

dsPIC33FJ06GS101/X02 and dsPIC33FJ16GSX02/X04

32. Module: High-Speed PWM

The PENH and PENL bits in the IOCONx register are used to assign ownership of the pins to either the PWM module or the GPIO module. The correct procedure to configure the PWM module is to assign pin ownership to the PWM module and then enabling it using the PTEN bit in the PTCN register.

If the PWM module is enabled using the above sequence, then a glitch may be observed on the PWM pins before actual switching of the PWM outputs begins. This glitch may cause momentary turn-on of power MOSFETs that are driven by the PWM pins and may cause damage to the application hardware.

Work around

Follow the given sequence to avoid any glitches from appearing on the PWM outputs at the time of enabling.

1. Configure the respective PWM pins to digital inputs using the TRISx registers. This step will put the PWM pins in a high-impedance state. The PWM outputs must be maintained in a safe state by using pull-up or pull-down resistors.

2. Assign pin ownership to the GPIO module by configuring IOCONx<PENH> = 0 and IOCONx<PENL> = 0.
3. Specify the PWM override state to the desired safe state for the PWM pins using the OVRDAT<1:0> bit field in the IOCONx register.
4. Override the PWM outputs by setting IOCONx<OVRENH> = 1 and IOCONx<OVRENL> = 1.
5. Enable the PWM module by setting PTCN<PTEN> = 1.
6. Remove the PWM overrides by making IOCONx<OVRENH> = 0 and IOCONx<OVRENL> = 0.
7. Ensure a delay of at least one full PWM cycle.
8. Assign pin ownership to the PWM module by setting IOCONx<PENH> = 1 and IOCONx<PENL> = 1.

The code in [Example 3](#) illustrates the use of this work around.

Affected Silicon Revisions

A2	A3	A4					
X	X	X					

EXAMPLE 3: CONFIGURE PWM MODULE TO PREVENT GLITCHES ON PWM1H AND PWM1L PINS AT THE TIME OF ENABLING

```
TRISAbits.TRISA4 = 1; // Configure PWM1H/RA4 as digital input
                      // Ensure output is in safe state using pull-up or
                      // pull-down resistors
TRISAbits.TRISA3 = 1; // Configure PWM1L/RA3 as digital input
                      // Ensure output is in safe state using pull-up or
                      // pull-down resistors

IOCON1bits.PENH = 0; // Assign pin ownership of PWM1H/RA4 to GPIO module
IOCON1bits.PENL = 0; // Assign pin ownership of PWM1L/RA3 to GPIO module

IOCON1bits.OVRDAT = 0; // Configure override state of the PWM outputs to
                      // desired safe state.

IOCON1bits.OVRENH = 1; // Override PWM1H output
IOCON1bits.OVRENL = 1; // Override PWM1L output

PTCONbits.PTEN = 1; // Enable PWM module

IOCON1bits.OVRENH = 0; // Remove override for PWM1H output
IOCON1bits.OVRENL = 0; // Remove override for PWM1L output

Delay(x); // Introduce a delay greater than one full PWM cycle

IOCON1bits.PENH = 1; // Assign pin ownership of PWM1H/RA4 to PWM module
IOCON1bits.PENL = 1; // Assign pin ownership of PWM1L/RA3 to PWM module
```

dsPIC33FJ06GS101/X02 and dsPIC33FJ16GSX02/X04

33. Module: Reserved

The issue in a previous version of the document was removed.

34. Module: PWM

The High-Speed PWM provides a feature to update the PWM duty cycle at any time during the PWM period. The new duty cycle should take effect:

- On the next PWM period when immediate duty cycle updates are disabled (PWMCONx<IUE> = 0).
- On the same PWM period when immediate duty cycle updates are enabled (PWMCONx<IUE> = 1).

However, when the immediate duty cycle updates are disabled and the duty cycle update coincides with a PWM period roll-over, the PWM output may be corrupted and exhibit a 100% duty cycle for one PWM period. The new duty cycle value will take effect on the next PWM period.

Work around

Enable immediate duty cycle updates by configuring PWMCONx<IUE> = 1.

Affected Silicon Revisions

A2	A3	A4					
X	X	X					

35. Module: JTAG

In JTAG mode, the TMS pin will not have an active pull-up as required by the JTAG specification. Instead, the pull-up function will be enabled on the TCK pin.

Note: This issue is only present in the dsPIC33FJ06GS101 device.

Work around

An external pull-up resistor can be connected to the TMS pin to ensure that the signal does not enter a tri-state condition when in JTAG mode.

There is no work around for the wrongly enabled pull-up function on the TCK pin.

Affected Silicon Revisions

A2	A3	A4					
X	X	X					

36. Module: SPI

When the SPI module is configured in Framed Master mode and the Frame Sync Pulse Edge Select bit (FRMDLY) is set to '1', transmitting a word and then buffering another word in the SPIxBUF register before the transmission has completed, results in an incomplete transmission of the first data word. Only the first 15 bits from the first data word are transmitted, followed by the sync pulse and the complete second word.

Work around

Between the two back-to-back SPI operations, add a delay to ensure that the first word is fully transmitted before the second word is written to the SPIxBUF register, as shown in [Example 4](#).

EXAMPLE 4:

```
SPI1BUF = 0x0001;

while (SPI1STATbits.SPITBF);

    asm ("REPEAT #50");.
    asm ("NOP");

// The number of NOPs depends on the SPI
// clock prescalers

SPI1BUF = 0x0002;
```

Affected Silicon Revisions

A2	A3	A4					
X	X	X					

37. Module: Comparator

With the DAC output is disabled by clearing the DACOEN bit (CMPCONx<8>), output signal transitions occurring on the DACOUT pin can cause the comparator trigger voltage level to change. For example, if the UART1 Transmit (U1TX) signal is mapped to the same pin as DACOUT, UART data transmissions can cause the comparator to get triggered at different trigger levels than what is programmed through the CMPDACx register.

Work around

When the comparator is enabled, do not use the DACOUT pin, either as a general purpose I/O pin or a peripheral output signal.

Affected Silicon Revisions

A2	A3	A4					
X	X	X					

dsPIC33FJ06GS101/X02 and dsPIC33FJ16GSX02/X04

38. Module: CPU

When a previous `DISI` instruction is active (i.e., the `DISCNT` register is non-zero), and the value of the `DISCNT` register is updated manually, the `DISCNT` register freezes and disables interrupts permanently.

Work around

Avoid updating the `DISCNT` register manually. Instead, use the `DISI #n` instruction with the required value for 'n'.

Affected Silicon Revisions

A2	A3	A4					
X	X	X					

39. Module: CPU

When using the Signed 32-by-16-bit Division instruction, `div.sd`, the overflow bit does not always get set when an overflow occurs.

Work around

Test for and handle overflow conditions outside of the `div.sd` instruction.

Affected Silicon Revisions

A2	A3	A4					
X	X	X					

40. Module: UART

When using `UTXISEL = 01` (interrupt when last character is shifted out of the Transmit Shift Register) and the final character is being shifted out through the Transmit Shift Register, the Transmit (TX) interrupt may occur before the final bit is shifted out.

Work around

If it is critical that the interrupt processing occur only when all transmit operations are complete. Hold off the interrupt routine processing by adding a loop at the beginning of the routine that polls the Transmit Shift Register Empty bit (TRMT) before processing the rest of the interrupt.

Affected Silicon Revisions

A2	A3	A4					
X	X	X					

41. Module: JTAG

JTAG Flash programming is not supported.

Work around

None.

Affected Silicon Revisions

A2	A3	A4					
X	X	X					

42. Module: PWM

If the PWM Clock Divider Select register, `PTCON2`, is not equal to zero, the PWM module may or may not initialize from an override state (`IOCONxbits.OVRENH = 1` or `IOCONxbits.OVRENL = 1`).

Work around

When configuring the Override Enable bits (`OVRENL/OVRENH`) in the PWMx I/O Control register, `IOCONx`, set these bits implicitly via word format and not explicitly via bit format.

For example:

```
IOCONx = IOCONx & 0xFCFF;
```

Affected Silicon Revisions

A2	A3	A4					
X	X	X					

dsPIC33FJ06GS101/X02 and dsPIC33FJ16GSX02/X04

43. Module: PWM

If the PWM is configured for Complimentary mode and the SWAP bit is enabled, the PWM outputs might operate as Redundant mode when the PHASE value is greater than the programmed dead-time (DTRx) value.

Work around

Using true independent output mode with the independent Time Base mode bit (ITB) set to '0', the PWMx module can be configured to replicate the original complementary signal by properly setting up the phase (PHASEx, SPASEx) and the independent duty cycle (PDCx, SDCx).

Affected Silicon Revisions

A2	A3	A4					
X	X	X					

44. Module: PWM

The PWMx current-limit operation allows the PWMx module to set/reset the output signals when a specific current limit is detected with a minimum latency delay. When operating the PWMx module in Complementary mode (PMOD = 0), positive dead time, and with Current-Limit Interrupt Enable (CLIEN = 1), a less than 8-ns pulse glitch on the complementary output may be present right after the current limit is detected. This glitch, if present, will occur prior to the implementation of the dead time.

Work around

In order to avoid the <8 ns glitch to be propagated into the MOSFET gate driver, a low-pass filter (e.g., resistor-capacitor network) should be implemented between the dsPIC[®] DSC PWMx output pin and the gate driver IC input pin.

Affected Silicon Revisions

A2	A3	A4					
X	X	X					

45. Module: PWM

The PWMx generator may not assert dead time on the edges of transitions. This has been observed when all of the following conditions are present:

- The PWMx generator is configured to operate in Complementary mode with the independent time base or master time base;
- Immediate update is enabled; and
- The value in the PDCx register is updated in such a manner that the PWMxH and PWMxL outputs make an immediate transition.

The current duty cycle, PDCOLD, newly calculated duty cycle, PDCNEW, and the point at which the write to the Duty Cycle register occurs within the PWMx time base, will determine if the PWMxH and PWMxL outputs make an immediate transition. PWMxH and PWMxL outputs make an immediate transition if the Duty Cycle register is written with a new value, PDCNEW, at a point of time when the PWMx time base is counting a value that is in between PDCNEW and PDCOLD. Additionally, writing to the Duty Cycle register close to the instant of time where dead time is being applied may result in reduced dead time, effective on the PWMxH and PWMxL transition edges.

In [Figure 1](#) (following page), if the duty cycle write occurred in the shaded box, then PWMxH and PWMxL will make an immediate transition without dead time.

Work around

None. However, in most applications the duty cycle update timing can be controlled using the TRIGx trigger or Special Event Trigger such that the above mentioned conditions are avoided altogether.

Affected Silicon Revisions

A2	A3	A4					
X	X	X					

dsPIC33FJ06GS101/X02 and dsPIC33FJ16GSX02/X04

FIGURE 1: TIMING DIAGRAMS FOR CENTER-ALIGNED AND EDGE-ALIGNED MODES

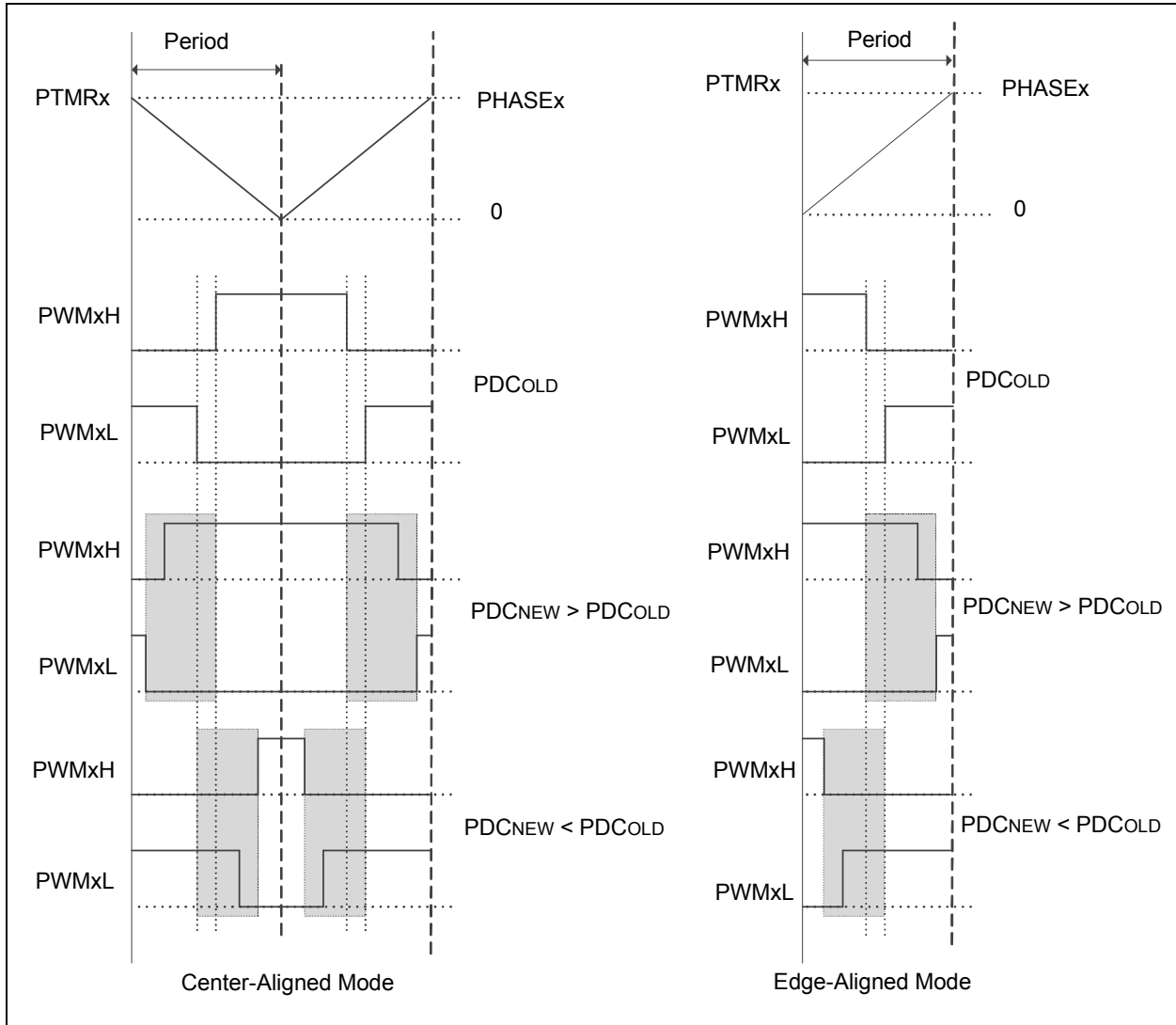

46. Module: ADC

Depending on device start-up conditions, measuring the internal voltage reference (INTREF) with the ADC may return a value of 0V in the result buffer.

Work around

None.

Affected Silicon Revisions

A2	A3	A4					
X	X	X					

dsPIC33FJ06GS101/X02 and dsPIC33FJ16GSX02/X04

47. Module: PWM

In Redundant Output mode (IOCONx<11:10> = 01) and Push-Pull Output mode (IOCONx<11:10> = 10), with the Immediate Update disabled (PWMCONx<0> = 0), when the Duty Cycle register is updated from a non-zero value to zero, a glitch pulse of a width equal to 1 PWM clock will appear at the next PWM period boundary, as shown in Figure 2 (for the Redundant Output mode). The Duty Cycle register refers to the PDCx register if PWMCONx<8> = 0 or the MDC register if PWMCONx<8> = 1.

FIGURE 2: ISSUE EXAMPLE FOR REDUNDANT OUTPUT MODE

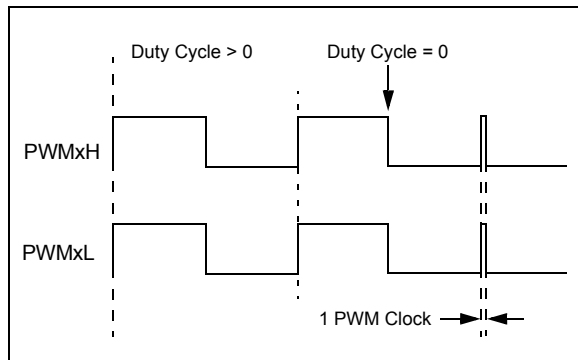

Work around

If the application requires a zero duty cycle output, there are two possible work around methods:

1. Use the PWM override feature to override the PWM output to a low state instead of writing to the Duty Cycle register. In order to switch back to a non-zero duty cycle output, turn off the PWM override. The override-on and override-off events must be timed close to the PWM period boundary if the IOCONx register has been configured with IOCON<0> = 0 (i.e., output overrides through the OVRDAT<1:0> bits occur on the next CPU clock boundary).
2. Enable the Immediate Update bit (PWMCONx<0> = 1) while configuring the PWMx module (i.e., before enabling the PWMx module (PTCON<15> = 1)). With Immediate Update enabled, writes to the Duty Cycle register can have an immediate effect on the PWM output. Therefore, the duty cycle write operations must be timed close to the PWM period boundary in order to avoid distortions in the PWM output.

Affected Silicon Revisions

A2	A3	A4					
X	X	X					

48. Module: PWM

In Edge-Aligned PWM mode with Master Time Base (PWMCONx<9> = 0) and Immediate Update disabled (PWMCONx<0> = 0), after enabling the PWMx module (PTCON<15> = 1), changes to the PHASEx register, such that PHASEx < DTRx or PHASEx > PDCx, will result in missing dead time at the PWMxH-PWMxL transition that will occur at the next master period boundary.

Work around

None.

Affected Silicon Revisions

A2	A3	A4					
X	X	X					

49. Module: PWM

The triggers generated by the PWMx Primary Trigger Compare Value register (TRIGx) and PWMx Secondary Trigger Compare Value register (STRIGx) will not trigger at the point defined by the TRIGx/STRIGx register values on the first instance of the configurations listed below. Subsequent trigger instances are not affected.

- Trigger compare values for TRIGx and STRIGx are less than 8 counts
- Trigger Output Divider bits, TRGDIV<3:0> (TRGCONx<15:12>), are greater than '0'
- Trigger Postscaler Start Enable Select bits, TRGSTRT<5:0> (TRGCONx<5:0>), are greater than '0'

Work around

Configure the PWMx Primary Trigger Compare Value register (TRIGx) and PWMx Secondary Trigger Compare Value register (STRIGx) values to be equal to or greater than 8.

Affected Silicon Revisions

A2	A3	A4					
X	X	X					

dsPIC33FJ06GS101/X02 and dsPIC33FJ16GSX02/X04

50. Module: I²C

In Slave mode, clock stretching may not occur, even when it has been enabled (STREN = 1). As a result, the SCLREL bit may not be cleared upon address reception when the R/W bit is '0'. This is seen in both 7-Bit and 10-Bit Address modes.

Work around

None.

Affected Silicon Revisions

A2	A3	A4					
X	X	X					

Data Sheet Clarifications

The following typographic corrections and clarifications are to be noted for the latest version of the device data sheet (DS70000318G):

Note: Corrections are shown in **bold**. Where possible, the original bold text formatting has been removed for clarity.

None.

dsPIC33FJ06GS101/X02 and dsPIC33FJ16GSX02/X04

APPENDIX A: REVISION HISTORY

Rev A Document (3/2009)

Initial release of this document; issued for revision A2 silicon.

Includes silicon issues 1-9 ([PWM](#)), 10 ([Comparator](#)), 11 ([ADC](#)), 12 ([Auxiliary Clock](#)), 13 ([Comparator](#)), 14-15 ([UART](#)) and 16 ([I²C™](#)).

Rev B Document (4/2009)

Added silicon issue 17 ([PWM](#)).

Rev C Document (5/2009)

Updated silicon issue 17 ([PWM](#)) to clarify which ADC pairs are involved.

Rev D Document (5/2009)

Revised to include revision A3 silicon information. Added silicon issues 18 ([Core](#)), 19 ([UART](#)) and 20-21 ([PWM](#)).

Added data sheet clarification 1 (The following typographic corrections and clarifications are to be noted for the latest version of the device data sheet (DS70000318G):).

Rev E Document (8/2009)

Added silicon issues 22-23 ([UART](#)), 24-25 ([I²C](#)), 26 ([PSV Operations](#)), 27 ([Comparator](#)) and 28 ([PWM](#)).

Rev F Document (1/2010)

Added silicon issues 29 ([Analog Comparator](#)) and 30 ([Auxiliary PLL](#)).

Added data sheet clarification 2 (Auxiliary PLL).

Rev G Document (6/2010)

Added silicon issues 31 ([ADC](#)) and 32 ([High-Speed PWM](#)) and data sheet clarification 3 ([DC Characteristics: I/O Pin Input Specifications](#)).

Rev H Document (10/2010)

Added revision A4 silicon information to all tables.

Updated the work arounds for silicon issue 31 ([ADC](#)).

Removed silicon issue 33 ([PWM](#)) and marked its location as reserved.

Added silicon issues 34 ([PWM](#)) and 35 ([JTAG](#)).

Rev J Document (3/2011)

Updated silicon issue 29 ([Analog Comparator](#)).

Added silicon issues 36 ([SPI](#)) and 37 ([Comparator](#)).

Added data sheet clarification 4.

Rev K Document (11/2011)

Added silicon issues 38 ([CPU](#)), 39 ([CPU](#)), 40 ([UART](#)), 41 ([JTAG](#)), and 42 ([PWM](#)).

Rev L Document (5/2012)

Removed data sheet clarifications 2, 3 and 4.

Updated silicon issues 29 ([Analog Comparator](#)) and 32 ([High-Speed PWM](#)).

Added silicon issues 43 ([PWM](#)) and 44 ([PWM](#)).

Rev M Document (1/2013)

Amended silicon issue 43 with correct PWM Clock Divider Select register bit name (changed from PTCON to PTCON2).

Included silicon issue 45 ([PWM](#)).

Rev N Document (9/2013)

Removed existing silicon issue 42 ([PWM](#)); subsequent issues are renumbered accordingly.

Added new silicon issues 45 ([PWM](#)) and 46 ([ADC](#)).

Added new data sheet clarification 2 (Packaging).

Corrected the module for issue 18 from “PGEC3/PGED3 Programming Pins” to “Core”, to conform with standard nomenclature practice (the issue itself is unchanged).

Rev P Document (10/2014)

Added new silicon issues 47, 48 and 49 ([PWM](#)).

Removed data sheet clarifications 1 and 2.

Rev Q Document (1/2015)

Added new silicon issue 50 ([I²C](#)).

Note the following details of the code protection feature on Microchip devices:

- Microchip products meet the specification contained in their particular Microchip Data Sheet.
- Microchip believes that its family of products is one of the most secure families of its kind on the market today, when used in the intended manner and under normal conditions.
- There are dishonest and possibly illegal methods used to breach the code protection feature. All of these methods, to our knowledge, require using the Microchip products in a manner outside the operating specifications contained in Microchip's Data Sheets. Most likely, the person doing so is engaged in theft of intellectual property.
- Microchip is willing to work with the customer who is concerned about the integrity of their code.
- Neither Microchip nor any other semiconductor manufacturer can guarantee the security of their code. Code protection does not mean that we are guaranteeing the product as “unbreakable.”

Code protection is constantly evolving. We at Microchip are committed to continuously improving the code protection features of our products. Attempts to break Microchip's code protection feature may be a violation of the Digital Millennium Copyright Act. If such acts allow unauthorized access to your software or other copyrighted work, you may have a right to sue for relief under that Act.

Information contained in this publication regarding device applications and the like is provided only for your convenience and may be superseded by updates. It is your responsibility to ensure that your application meets with your specifications. MICROCHIP MAKES NO REPRESENTATIONS OR WARRANTIES OF ANY KIND WHETHER EXPRESS OR IMPLIED, WRITTEN OR ORAL, STATUTORY OR OTHERWISE, RELATED TO THE INFORMATION, INCLUDING BUT NOT LIMITED TO ITS CONDITION, QUALITY, PERFORMANCE, MERCHANTABILITY OR FITNESS FOR PURPOSE. Microchip disclaims all liability arising from this information and its use. Use of Microchip devices in life support and/or safety applications is entirely at the buyer's risk, and the buyer agrees to defend, indemnify and hold harmless Microchip from any and all damages, claims, suits, or expenses resulting from such use. No licenses are conveyed, implicitly or otherwise, under any Microchip intellectual property rights.

Trademarks

The Microchip name and logo, the Microchip logo, dsPIC, FlashFlex, flexPWR, JukeBlox, KEELOQ, KEELOQ logo, Klear, LANCheck, MediaLB, MOST, MOST logo, MPLAB, OptoLyzer, PIC, PICSTART, PIC³² logo, RightTouch, SpyNIC, SST, SST Logo, SuperFlash and UNI/O are registered trademarks of Microchip Technology Incorporated in the U.S.A. and other countries.

The Embedded Control Solutions Company and mTouch are registered trademarks of Microchip Technology Incorporated in the U.S.A.

Analog-for-the-Digital Age, BodyCom, chipKIT, chipKIT logo, CodeGuard, dsPICDEM, dsPICDEM.net, ECAN, In-Circuit Serial Programming, ICSP, Inter-Chip Connectivity, KlearNet, KlearNet logo, MiWi, MPASM, MPF, MPLAB Certified logo, MPLIB, MPLINK, MultiTRAK, NetDetach, Omniscient Code Generation, PICDEM, PICDEM.net, PICkit, PICtail, RightTouch logo, REAL ICE, SQI, Serial Quad I/O, Total Endurance, TSHARC, USBCheck, VariSense, ViewSpan, WiperLock, Wireless DNA, and ZENA are trademarks of Microchip Technology Incorporated in the U.S.A. and other countries.

SQTP is a service mark of Microchip Technology Incorporated in the U.S.A.

Silicon Storage Technology is a registered trademark of Microchip Technology Inc. in other countries.

GestIC is a registered trademarks of Microchip Technology Germany II GmbH & Co. KG, a subsidiary of Microchip Technology Inc., in other countries.

All other trademarks mentioned herein are property of their respective companies.

© 2009-2015, Microchip Technology Incorporated, Printed in the U.S.A., All Rights Reserved.

ISBN: 978-1-63276-992-3

QUALITY MANAGEMENT SYSTEM
CERTIFIED BY DNV
== ISO/TS 16949 ==

Microchip received ISO/TS-16949:2009 certification for its worldwide headquarters, design and wafer fabrication facilities in Chandler and Tempe, Arizona; Gresham, Oregon and design centers in California and India. The Company's quality system processes and procedures are for its PIC® MCUs and dsPIC® DSCs, KEELOQ® code hopping devices, Serial EEPROMs, microperipherals, nonvolatile memory and analog products. In addition, Microchip's quality system for the design and manufacture of development systems is ISO 9001:2000 certified.



MICROCHIP

Worldwide Sales and Service

AMERICAS

Corporate Office
2355 West Chandler Blvd.
Chandler, AZ 85224-6199
Tel: 480-792-7200
Fax: 480-792-7277
Technical Support:
<http://www.microchip.com/support>
Web Address:
www.microchip.com

Atlanta
Duluth, GA
Tel: 678-957-9614
Fax: 678-957-1455

Austin, TX
Tel: 512-257-3370

Boston
Westborough, MA
Tel: 774-760-0087
Fax: 774-760-0088

Chicago
Itasca, IL
Tel: 630-285-0071
Fax: 630-285-0075

Cleveland
Independence, OH
Tel: 216-447-0464
Fax: 216-447-0643

Dallas
Addison, TX
Tel: 972-818-7423
Fax: 972-818-2924

Detroit
Novi, MI
Tel: 248-848-4000

Houston, TX
Tel: 281-894-5983

Indianapolis
Noblesville, IN
Tel: 317-773-8323
Fax: 317-773-5453

Los Angeles
Mission Viejo, CA
Tel: 949-462-9523
Fax: 949-462-9608

New York, NY
Tel: 631-435-6000

San Jose, CA
Tel: 408-735-9110

Canada - Toronto
Tel: 905-673-0699
Fax: 905-673-6509

ASIA/PACIFIC

Asia Pacific Office
Suites 3707-14, 37th Floor
Tower 6, The Gateway
Harbour City, Kowloon
Hong Kong
Tel: 852-2943-5100
Fax: 852-2401-3431

Australia - Sydney
Tel: 61-2-9868-6733
Fax: 61-2-9868-6755

China - Beijing
Tel: 86-10-8569-7000
Fax: 86-10-8528-2104

China - Chengdu
Tel: 86-28-8665-5511
Fax: 86-28-8665-7889

China - Chongqing
Tel: 86-23-8980-9588
Fax: 86-23-8980-9500

China - Hangzhou
Tel: 86-571-8792-8115
Fax: 86-571-8792-8116

China - Hong Kong SAR
Tel: 852-2943-5100
Fax: 852-2401-3431

China - Nanjing
Tel: 86-25-8473-2460
Fax: 86-25-8473-2470

China - Qingdao
Tel: 86-532-8502-7355
Fax: 86-532-8502-7205

China - Shanghai
Tel: 86-21-5407-5533
Fax: 86-21-5407-5066

China - Shenyang
Tel: 86-24-2334-2829
Fax: 86-24-2334-2393

China - Shenzhen
Tel: 86-755-8864-2200
Fax: 86-755-8203-1760

China - Wuhan
Tel: 86-27-5980-5300
Fax: 86-27-5980-5118

China - Xian
Tel: 86-29-8833-7252
Fax: 86-29-8833-7256

China - Xiamen
Tel: 86-592-2388138
Fax: 86-592-2388130

China - Zhuhai
Tel: 86-756-3210040
Fax: 86-756-3210049

ASIA/PACIFIC

India - Bangalore
Tel: 91-80-3090-4444
Fax: 91-80-3090-4123

India - New Delhi
Tel: 91-11-4160-8631
Fax: 91-11-4160-8632

India - Pune
Tel: 91-20-3019-1500

Japan - Osaka
Tel: 81-6-6152-7160
Fax: 81-6-6152-9310

Japan - Tokyo
Tel: 81-3-6880-3770
Fax: 81-3-6880-3771

Korea - Daegu
Tel: 82-53-744-4301
Fax: 82-53-744-4302

Korea - Seoul
Tel: 82-2-554-7200
Fax: 82-2-558-5932 or
82-2-558-5934

Malaysia - Kuala Lumpur
Tel: 60-3-6201-9857
Fax: 60-3-6201-9859

Malaysia - Penang
Tel: 60-4-227-8870
Fax: 60-4-227-4068

Philippines - Manila
Tel: 63-2-634-9065
Fax: 63-2-634-9069

Singapore
Tel: 65-6334-8870
Fax: 65-6334-8850

Taiwan - Hsin Chu
Tel: 886-3-5778-366
Fax: 886-3-5770-955

Taiwan - Kaohsiung
Tel: 886-7-213-7830

Taiwan - Taipei
Tel: 886-2-2508-8600
Fax: 886-2-2508-0102

Thailand - Bangkok
Tel: 66-2-694-1351
Fax: 66-2-694-1350

EUROPE

Austria - Wels
Tel: 43-7242-2244-39
Fax: 43-7242-2244-393

Denmark - Copenhagen
Tel: 45-4450-2828
Fax: 45-4485-2829

France - Paris
Tel: 33-1-69-53-63-20
Fax: 33-1-69-30-90-79

Germany - Dusseldorf
Tel: 49-2129-3766400

Germany - Munich
Tel: 49-89-627-144-0
Fax: 49-89-627-144-44

Germany - Pforzheim
Tel: 49-7231-424750

Italy - Milan
Tel: 39-0331-742611
Fax: 39-0331-466781

Italy - Venice
Tel: 39-049-7625286

Netherlands - Drunen
Tel: 31-416-690399
Fax: 31-416-690340

Poland - Warsaw
Tel: 48-22-3325737

Spain - Madrid
Tel: 34-91-708-08-90
Fax: 34-91-708-08-91

Sweden - Stockholm
Tel: 46-8-5090-4654

UK - Wokingham
Tel: 44-118-921-5800
Fax: 44-118-921-5820

03/25/14