

TrEOS single-line ESD protection best-in-class solutions for high-speed data lines

Nexperia invented TrEOS to offer a combination of low capacitance, low clamping voltage and high ESD robustness, helping safeguard 10Gbps+ data lines systems.



Benefits

- › Maximized protection for all three ESD factors
- › Suited for USB 3.2 SuperSpeed & HDMI 2.x TMDs data lines
- › Reliable protection for sensitive transceiver SoCs
- › Exceeding IEC61000-4-2 level 4, IEC61000-4-5 grade robustness
- › Low capacitance silicon with deep snap-back

Features

- › 2 V, 2.5 V, 3.3 V, 4 V, 5 V, 6.5 V & 7 V V_{RWM} specification
- › Unmatched 8/20 μ s surge robustness (up to 20 A I_{PMM})
- › Ultra-low dynamic resistance/capacitance combination
- › Extremely fast switching time (under 1 ns)
- › Low-inductance & bondwire-free DSN0603-2

Protecting high-speed data lines against ESD

With conventional ESD protection, tradeoffs must be made between robustness, signal integrity and system protection, resulting in adequate protection on only two of these three core parameters.

For the purpose of protecting USB ports, low capacitance has customarily been valued at the detriment of protection against surge levels. However, today's high-speed interfaces like USB Type-C can subject systems to surge pulses, for example through defective cables that might discharge to the transceiver.

Nexperia's TrEOS solutions alleviate the traditional protection challenge by delivering benchmark performance in all areas and are housed in the extensively proven DSN0603-2 package:

- › Extremely low capacitance (down to 0.1 pF)
- › Extremely low clamping (down to 0.1 Ω)
- › High robustness against surge (up to 20 A 8/20 μ s)

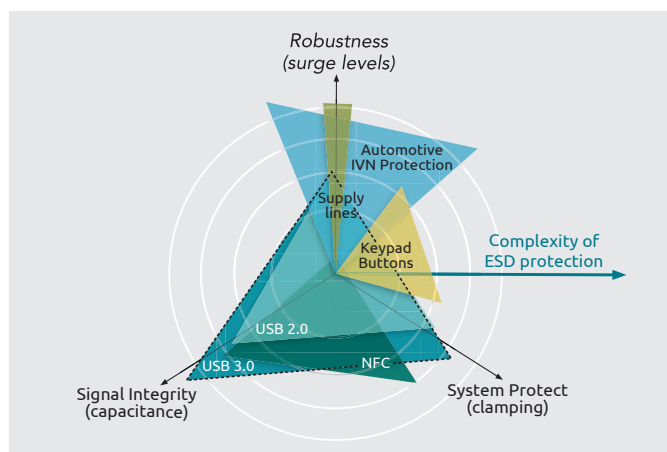

nexperia

EFFICIENCY WINS.

Nexperia TrEOS portfolio for high-speed data-lines

Our TrEOS family is composed of two subsets of devices which can be employed together or separately:

- Extremely high surge robustness devices are designed to be placed between the connector and AC capacitor to protect the decoupling capacitor and transceiver against possible peak pulses (up to 20 A).
- Extremely low peak voltages devices are designed to be placed between the capacitor and the device, offering industry-leading low-trigger voltage to maximize system-level protection (V_{et} as low as 4.3 V).

Combining a protection device from both subsets is suggested, to achieve ultimate ESD protection.

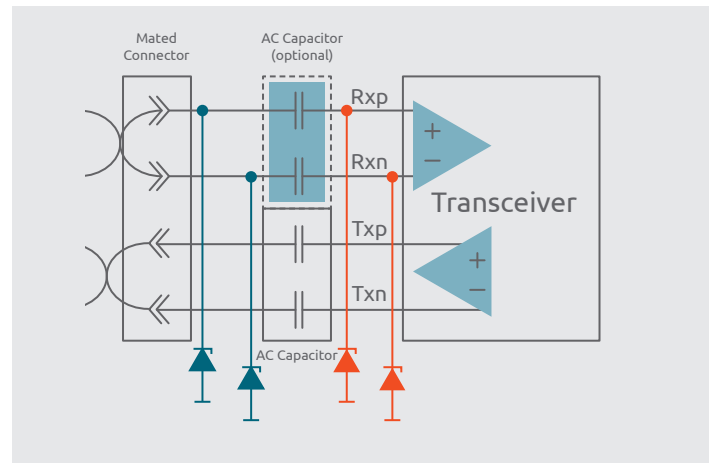

Parametrics

Types in **bold** represent new products.

	Type	Direction	Protected lines	V_{RWM} (V)	Cline typ (pF)	ESD rating max (kV)	Surge robustness 8/20 μ s (A)	R_{dyn} (Ω)	Package
Extremely high surge ratings	PESD3V3C1BSF	Bidirectional	1	3.3	0.2	20	9	0.23	DSN0603-2
	PESD3V3Z1BSF				0.28	20	9.5	0.19	
	PESD3V3Z1BCSF				0.45	25	15	0.11	
	PESD3V3W1BCSF				0.55	30	20	0.1	
	PESD4V0Z1BCSF			4	0.45	25	15	0.11	
	PESD4V0W1BCSF			0.55	30	20	0.1		
	PESD7V0R1BSF			7	0.1	10	4.5	0.45	
	PESD7V0H1BSF				0.15	15	7	0.25	
	PESD7V0C1BSF				0.2	20	9	0.23	
	PESD6V5C1USF	Unidirectional		6.5	0.45	20	9	0.1	

	Type	Direction	Protected lines	V_{RWM} (V)	Cline typ (pF)	ESD rating max (kV)	Trigger voltage V_{et} (V)	R_{dyn} (Ω)	Package
Extremely low peak voltages	PESD2V0Y1BSF	Bidirectional	1	2	0.69	20	4.3	0.2	DSN0603-2
	PESD2V5Y1BSF			2.5	0.25	15	4.9	0.23	
	PESD3V3Y1BSF			3.3	0.24	15	7	0.25	
	PESD4V0Y1BSF			4	0.24	15	7	0.25	

Package details

TrEOS solutions are available in the high-compactness, low-inductance, extreme-robustness DSN0603-2 package. Also known as SOD962-2, this small-footprint package requires just 0.36mm² and allows to reduce clamping voltage by up to 50% compared to bond-wire alternatives.

TrEOS solutions also exist with common mode filtering and for multi-line needs. Browse our full portfolio: <https://www.nexperia.com/products/esd-protection-tvs-filtering-and-signal-conditioning-esd-protection/family/TREOS-PROTECTION/>

Name	Package family	Dimensions (L x W x H, in mm)	
SOD962-2	DSN0603-2	0.6 x 0.3 x 0.3	

© 2019 Nexperia B.V.

All rights reserved. Reproduction in whole or in part is prohibited without the prior written consent of the copyright owner. The information presented in this document does not form part of any quotation or contract, is believed to be accurate and reliable and may be changed without notice. No liability will be accepted by the publisher for any consequence of its use. Publication thereof does not convey nor imply any license under patent- or other industrial or intellectual property rights.

Date of release:

February 2019

Printed:

In the Netherlands