



Product Change Notification / SYST-29ZQD0050

Date:

30-Mar-2023

Product Category:

Linear Op Amps

PCN Type:

Document Change

Notification Subject:

Data Sheet - MCP6486/7/9 - 10 MHz Operational Amplifier with EMI Filtering

Affected CPNs:

[SYST-29ZQD0050_Affected_CPN_03302023.pdf](#)

[SYST-29ZQD0050_Affected_CPN_03302023.csv](#)

Notification Text:

SYST-29ZQD0050

Microchip has released a new Datasheet for the MCP6486/7/9 - 10 MHz Operational Amplifier with EMI Filtering of devices. If you are using one of these devices please read the document located at [MCP6486/7/9 - 10 MHz Operational Amplifier with EMI Filtering](#).

Notification Status: Final

Description of Change:

- Corrected title for Figure 2-8.
- Added packaging information for MCP6489-E/ST and MCP6489T-E/ST in Product Identification System.
- Added section Product Identification System (Automotive).

Impacts to Data Sheet: See above details

Reason for Change: To Improve Productivity

Change Implementation Status: Complete

Date Document Changes Effective: 30 Mar 2023

NOTE: Please be advised that this is a change to the document only the product has not been changed.

Markings to Distinguish Revised from Unrevised Devices::N/A

Attachments:

[MCP6486/7/9 - 10 MHz Operational Amplifier with EMI Filtering](#)

Please contact your local [Microchip sales office](#) with questions or concerns regarding this notification.

Terms and Conditions:

If you wish to receive Microchip PCNs via email please register for our PCN email service at our [PCN home page](#) select register then fill in the required fields. You will find instructions about registering for Microchips PCN email service in the [PCN FAQ](#) section.

If you wish to change your PCN profile, including opt out, please go to the [PCN home page](#) select login and sign into your myMicrochip account. Select a profile option from the left navigation bar and make the applicable selections.

Affected Catalog Part Numbers (CPN)

MCP6489-E/SL
MCP6489-E/SLVAO
MCP6489-E/ST
MCP6489-E/STVAO
MCP6489T-E/SL
MCP6489T-E/SLVAO
MCP6489T-E/ST
MCP6489T-E/STVAO
MCP6487-E/MS
MCP6487-E/MSVAO
MCP6487-E/SN
MCP6487-E/SNVAO
MCP6487T-E/MS
MCP6487T-E/MSVAO
MCP6486T-E/LT
MCP6486UT-E/LT
MCP6486UT-E/LTVAO
MCP6487T-E/SN
MCP6487T-E/SNVAO
MCP6486T-E/OT
MCP6486UT-E/OT
MCP6486RT-E/OT
MCP6486T-E/OTVAO

10 MHz Operational Amplifier with EMI Filtering

Features

- **Low Quiescent Current:**
 - 720 μ A (maximum)/amplifier
- **Low Input Offset Voltage:**
 - ± 1.6 mV (maximum)
- Enhanced EMI Protection
- Supply Voltage Range: 1.8V to 5.5V
- Gain Bandwidth Product: 10 MHz (typical)
- Rail-to-Rail Input/Output
- Unity Gain Stable
- No Phase Reversal
- Quick Start-up Time
- **Small Packages:**
 - Singles in SC70-5, SOT-23-5
 - Dual in SOIC-8, MSOP-8
 - Quad in SOIC-14, TSSOP-14
- Extended Temperature Range: -40°C to $+125^{\circ}\text{C}$
- AEC Q100 Qualified, see [Section "Product Identification System \(Automotive\)"](#)

Applications

- Automotive
- Portable Equipment
- Medical Diagnostic Equipment
- Active Filters
- Sensor Conditioning

Design Aids

- SPICE Macro Models
- Microchip Advanced Part Selector (MAPS)
- Analog Demonstration and Evaluation Boards
- Application Notes

Start-Up Time

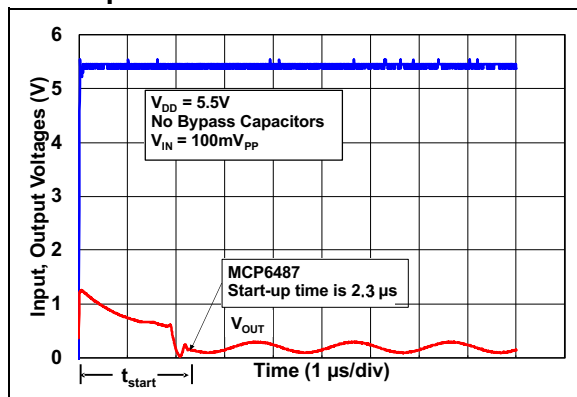

Description

The Microchip Technology Inc. MCP6486/6R/6U/7/9 Operational Amplifier operates with a single-supply voltage, as low as 1.8V, while drawing low-quiescent current (720 μ A, maximum per amplifier). This op amp also has low-input offset voltage (± 1.6 mV, maximum) and rail-to-rail input and output operation. In addition, the MCP6486/6R/6U/7/9 is unity gain stable and has a gain bandwidth product of 10 MHz (typical).

The MCP6486/6R/6U/7/9 has EMI protection to minimize the effects of electromagnetic interference from external sources. This feature makes it suited for EMI sensitive applications such as power lines, radio stations and mobile communications.

This family is offered in single (MCP6486), dual (MCP6487) and quad (MCP6489) packages. All devices are designed using an advanced CMOS process and fully specified in the extended temperature range from -40°C to $+125^{\circ}\text{C}$.

Package Types

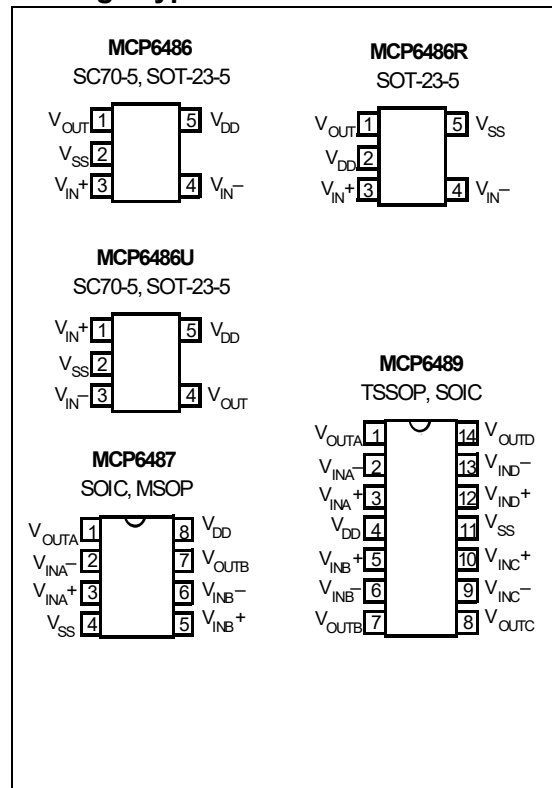

MCP6486/6R/6U/7/9

1.0 ELECTRICAL CHARACTERISTICS

1.1 Absolute Maximum Ratings†

$V_{DD} - V_{SS}$	6V
Current at Analog Input Pins (V_{IN+} , V_{IN-})	±5 mA
Analog Inputs (V_{IN+} , V_{IN-})††	$V_{SS} - 0.5V$ to $V_{DD} + 0.5V$
Analog Outputs (V_{OUT})	$V_{SS} - 0.3V$ to $V_{DD} + 0.3V$
Difference Input Voltage	$ V_{DD} - V_{SS} $
Output Short-Circuit Current (Note 1)	Continuous
Storage Temperature	-65°C to +150°C
Maximum Junction Temperature (T_J)	+150°C
ESD Protection on All Pins (HBM; CDM; MM)	≥ 4 kV; 2 kV; 200V

Note 1: Short-circuit to ground, one amplifier per package

† **Notice:** Stresses above those listed under “Absolute Maximum Ratings” may cause permanent damage to the device. This is a stress rating only and functional operation of the device at those or any other conditions above those indicated in the operational listings of this specification is not implied. Exposure to maximum rating conditions for extended periods may affect device reliability.

†† See [Section 4.1.2 “Input Voltage Limits”](#).

1.2 Specifications

DC Electrical Specifications

Electrical Characteristics: Unless otherwise indicated, $T_A = +25^\circ\text{C}$, $V_{DD} = +1.8V$ to $+5.5V$, $V_{SS} = \text{GND}$, $V_{CM} = V_{DD}/4$, $V_{OUT} = V_{DD}/2$, $V_L = V_{DD}/2$, $R_L = 10\text{ k}\Omega$ to V_L and $C_L = 30\text{ pF}$.

Parameters	Sym.	Min.	Typ.	Max.	Units	Conditions
Input Offset						
Input Offset Voltage	V_{OS}	-1.6	—	1.6	mV	
Input Offset Drift with Temperature	$\Delta V_{OS}/\Delta T_A$	—	±0.6	—	$\mu\text{V}/^\circ\text{C}$	$T_A = -40^\circ\text{C}$ to $+125^\circ\text{C}$
Power Supply Rejection Ratio	PSRR	82	100	—	dB	
Input Bias Current and Impedance						
Input Bias Current	I_B	—	±1	—	pA	
		—	19	—	pA	$T_A = +85^\circ\text{C}$
		—	200	—	pA	$T_A = +125^\circ\text{C}$
Input Offset Current	I_{OS}	—	±1	—	pA	
Common Mode Input Impedance	Z_{CM}	—	$10^{13} 6$	—	ΩpF	
Differential Input Impedance	Z_{DIFF}	—	$10^{13} 2$	—	ΩpF	
Common Mode						
Common Mode Input Voltage Range	V_{CMR}	$V_{SS} - 0.3$	—	$V_{DD} + 0.3$	V	$T_A = -40^\circ\text{C}$ to $+125^\circ\text{C}$, Guaranteed by Characterization.
		$V_{SS} - 0.1$	—	$V_{DD} + 0.1$		
Common Mode Rejection Ratio	CMRR	—	125	—	dB	$V_{DD} = 5.5V$ $V_{CM} = -0.1V$ to $4.1V$
		66	110	—	dB	$V_{DD} = 5.5V$ $V_{CM} = -0.3V$ to $5.8V$
		—	75	—	dB	$V_{DD} = 1.8V$ $V_{CM} = -0.3V$ to $2.1V$

MCP6486/6R/6U/7/9

DC Electrical Specifications (Continued)

Electrical Characteristics: Unless otherwise indicated, $T_A = +25^\circ\text{C}$, $V_{DD} = +1.8\text{V}$ to $+5.5\text{V}$, $V_{SS} = \text{GND}$, $V_{CM} = V_{DD}/4$, $V_{OUT} = V_{DD}/2$, $V_L = V_{DD}/2$, $R_L = 10\text{ k}\Omega$ to V_L and $C_L = 30\text{ pF}$.

Parameters	Sym.	Min.	Typ.	Max.	Units	Conditions
Open-Loop Gain						
DC Open-Loop Gain (Large Signal)	A_{OL}	105	130	—	dB	$0.2 < V_{OUT} < (V_{DD} - 0.2\text{V})$
Output						
High-Level Output Voltage	V_{OH}	$V_{DD} - 10$	$V_{DD} - 3.5$	—	mV	$V_{DD} = 5.5\text{V}$, $R_L = 10\text{ k}\Omega$
		$V_{DD} - 50$	$V_{DD} - 30$	—		$V_{DD} = 5.5\text{V}$, $R_L = 1\text{ k}\Omega$
Low-Level Output Voltage	V_{OL}	—	$V_{SS} + 3.5$	$V_{SS} + 10$	mV	$V_{DD} = 5.5\text{V}$, $R_L = 10\text{ k}\Omega$
		—	$V_{SS} + 30$	$V_{SS} + 50$		$V_{DD} = 5.5\text{V}$, $R_L = 1\text{ k}\Omega$
Output Short-Circuit Current	I_{SC}	—	± 11	—	mA	$V_{DD} = 1.8\text{V}$
		—	± 50	—		$V_{DD} = 5.5\text{V}$
Power Supply						
Supply Voltage	V_{DD}	1.8	—	5.5	V	
Quiescent Current per Amplifier	I_Q	—	550	720	μA	$I_O = 0$
Startup Time	t_{start}	—	2.3	—	μs	$V_{DD} = 0\text{V}$ to 5.5V
Crosstalk		—	135	—	dB	

AC Electrical Specifications

Electrical Characteristics: Unless otherwise indicated, $T_A = +25^\circ\text{C}$, $V_{DD} = +1.8\text{V}$ to $+5.5\text{V}$, $V_{SS} = \text{GND}$, $V_{CM} = V_{DD}/4$, $V_{OUT} = V_{DD}/2$, $V_L = V_{DD}/2$, $R_L = 10\text{ k}\Omega$ to V_L and $C_L = 30\text{ pF}$.

Parameters	Sym.	Min.	Typ.	Max.	Units	Conditions
AC Response						
Gain Bandwidth Product	GBWP	—	10	—	MHz	
Phase Margin	PM	—	60	—	$^\circ$	$G = +1\text{ V/V}$
Slew Rate	SR	—	20	—	$\text{V}/\mu\text{s}$	$V_{DD} = 5.5\text{V}$, $V_{IN} > 4\text{V}$
Settling Time	t_s	—	0.4	—	μs	To 0.1%, $V_{DD} = 5\text{V}$, 2V step, $G = +1$
		—	0.5	—		To 0.01%, $V_{DD} = 5\text{V}$, 2V step, $G = +1$
Total Harmonic Distortion + Noise	THD+N	—	0.002	—	%	$V_{DD} = 5\text{V}$, $V_o = 1\text{ V}_{RMS}$, $G = +1$, $f = 1\text{ kHz}$, 80 kHz measurement BW.
Noise						
Input Noise Voltage	E_{ni}	—	3.4	—	μV_{P-P}	$f = 0.1\text{ Hz}$ to 10 Hz
Input Noise Voltage Density	e_{ni}	—	16	—	$\text{nV}/\sqrt{\text{Hz}}$	$f = 1\text{ kHz}$
		—	10	—	$\text{nV}/\sqrt{\text{Hz}}$	$f = 10\text{ kHz}$
Input Noise Current Density	i_{ni}	—	0.6	—	$\text{fA}/\sqrt{\text{Hz}}$	$f = 1\text{ kHz}$

MCP6486/6R/6U/7/9

AC Electrical Specifications (Continued)

Electrical Characteristics: Unless otherwise indicated, $T_A = +25^\circ\text{C}$, $V_{DD} = +1.8\text{V}$ to $+5.5\text{V}$, $V_{SS} = \text{GND}$, $V_{CM} = V_{DD}/4$, $V_{OUT} = V_{DD}/2$, $V_L = V_{DD}/2$, $R_L = 10\text{ k}\Omega$ to V_L and $C_L = 30\text{ pF}$.

Parameters	Sym.	Min.	Typ.	Max.	Units	Conditions
Electromagnetic Interference Rejection Ratio	EMIRR	—	30	—	dB	$V_{IN} = 100\text{ mV}_{PK}$, 400 MHz
		—	45	—		$V_{IN} = 100\text{ mV}_{PK}$, 900 MHz
		—	61	—		$V_{IN} = 100\text{ mV}_{PK}$, 1800 MHz
		—	82	—		$V_{IN} = 100\text{ mV}_{PK}$, 2400 MHz
		—	100	—		$V_{IN} = 100\text{ mV}_{PK}$, 5800 MHz

TABLE 1-1: TEMPERATURE SPECIFICATIONS

Electrical Characteristics: Unless otherwise indicated, $V_{DD} = +1.8\text{V}$ to $+5.5\text{V}$ and $V_{SS} = \text{GND}$.						
Parameters	Sym.	Min.	Typ.	Max.	Units	Conditions
Temperature Ranges						
Operating Temperature Range	T_A	-40	—	+125	$^\circ\text{C}$	Note 1
Storage Temperature Range	T_A	-65	—	+150	$^\circ\text{C}$	
Thermal Package Resistances						
Thermal Resistance, 5L-SC70	θ_{JA}	—	331	—	$^\circ\text{C}/\text{W}$	
Thermal Resistance, 5L-SOT-23	θ_{JA}	—	221	—	$^\circ\text{C}/\text{W}$	
Thermal Resistance, 8L-MSOP	θ_{JA}	—	206	—	$^\circ\text{C}/\text{W}$	
Thermal Resistance, 8L-SOIC	θ_{JA}	—	150	—	$^\circ\text{C}/\text{W}$	
Thermal Resistance, 14L-TSSOP	θ_{JA}	—	100	—	$^\circ\text{C}/\text{W}$	
Thermal Resistance, 14L-SOIC	θ_{JA}	—	120	—	$^\circ\text{C}/\text{W}$	

Note 1: The internal junction temperature (T_J) must not exceed the absolute maximum specification of $+150^\circ\text{C}$.

2.0 TYPICAL PERFORMANCE CURVES

Note: The graphs and tables provided following this note are a statistical summary based on a limited number of samples and are provided for informational purposes only. The performance characteristics listed herein are not tested or guaranteed. In some graphs or tables, the data presented may be outside the specified operating range (e.g., outside specified power supply range) and therefore outside the warranted range.

Note: Unless otherwise indicated, $T_A = +25^\circ\text{C}$, $V_{DD} = +1.8\text{V}$ to $+5.5\text{V}$, $V_{SS} = \text{GND}$, $V_{CM} = V_{DD}/4$, $V_{OUT} = V_{DD}/2$, $V_L = V_{DD}/2$, $R_L = 10\text{ k}\Omega$ to V_L and $C_L = 30\text{ pF}$.

2.1 DC Inputs

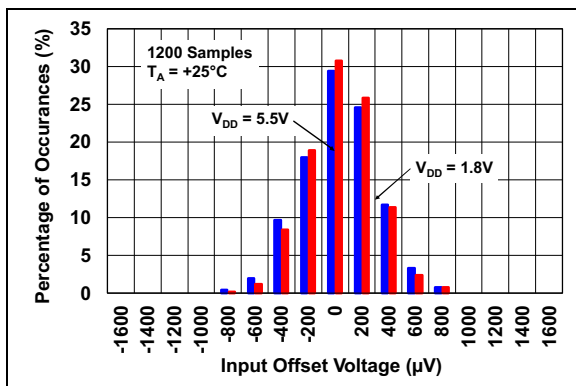

FIGURE 2-1: Input Offset Voltage Histogram.

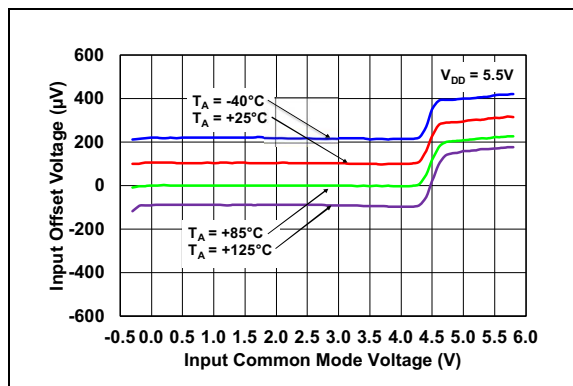

FIGURE 2-4: Input Offset Voltage vs. Common-Mode Input Voltage.

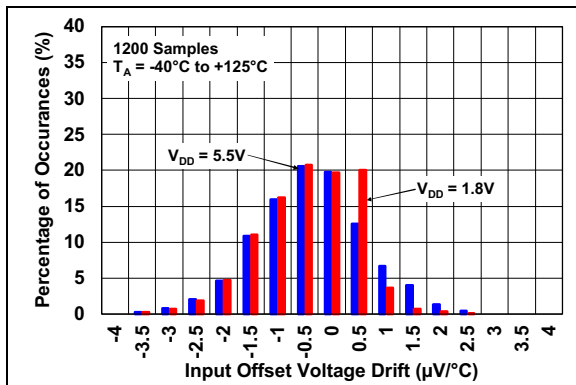

FIGURE 2-2: Input Offset Voltage Drift Histogram.

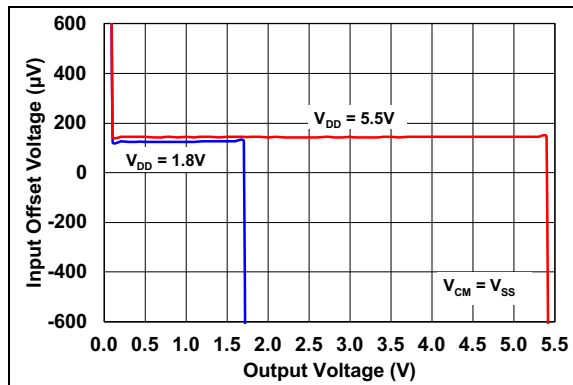

FIGURE 2-5: Input Offset Voltage vs. Output Voltage.

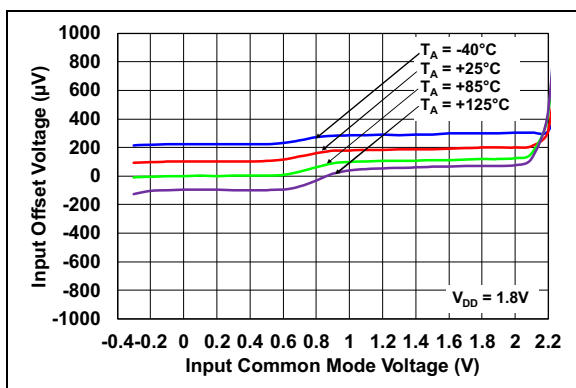

FIGURE 2-3: Input Offset Voltage vs. Common-Mode Input Voltage.

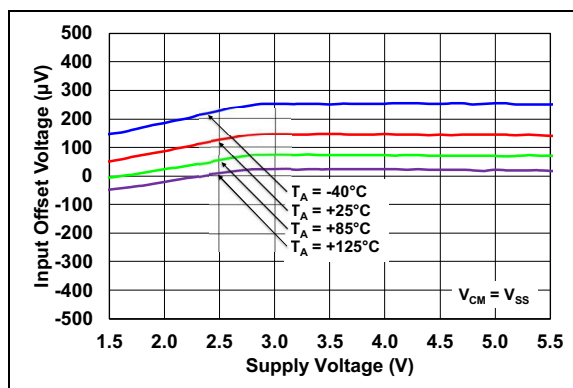

FIGURE 2-6: Input Offset Voltage vs. Power Supply Voltage.

MCP6486/6R/6U/7/9

Note: Unless otherwise indicated, $T_A = +25^\circ\text{C}$, $V_{DD} = +1.8\text{V}$ to $+5.5\text{V}$, $V_{SS} = \text{GND}$, $V_{CM} = V_{DD}/4$, $V_{OUT} = V_{DD}/2$, $V_L = V_{DD}/2$, $R_L = 10\text{ k}\Omega$ to V_L and $C_L = 30\text{ pF}$.

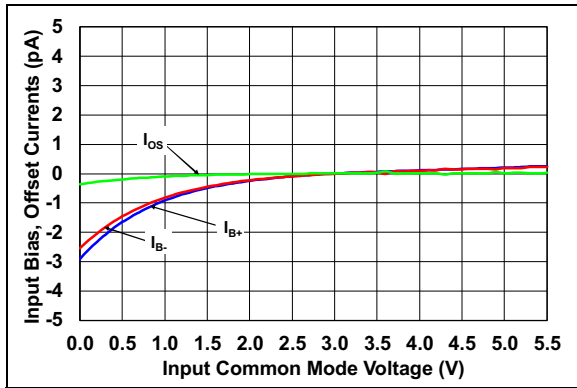

FIGURE 2-7: Input Bias, Offset Current vs. Common-Mode Input Voltage.

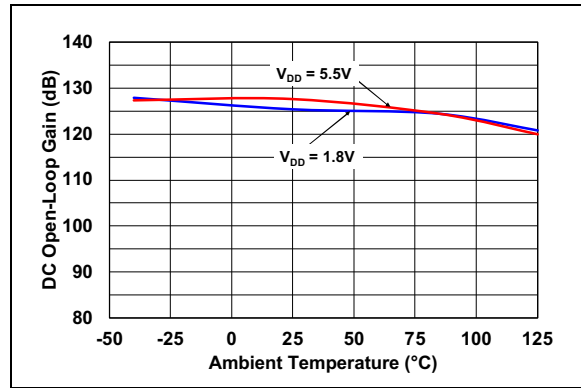

FIGURE 2-10: DC Open-Loop Gain vs. Ambient Temperature.

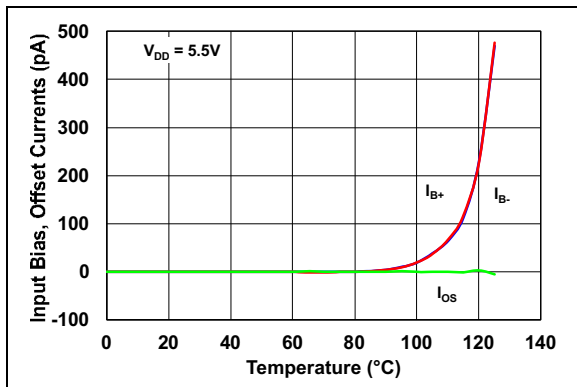

FIGURE 2-8: Input Bias, Offset Currents vs. Temperature.

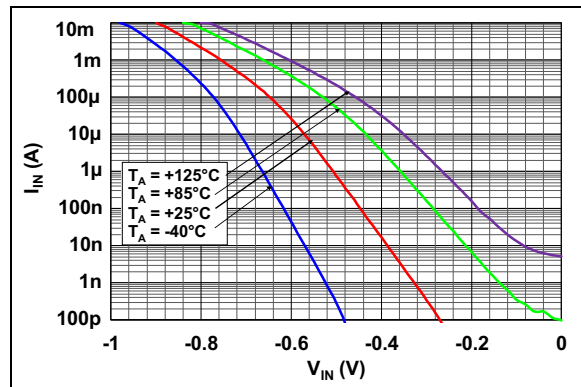

FIGURE 2-11: Measured Input Current vs. Input Voltage (below V_{SS}).

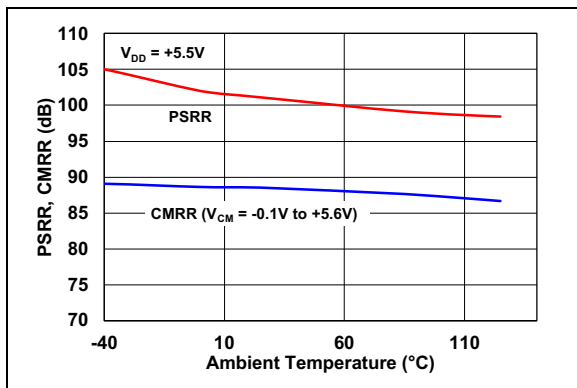

FIGURE 2-9: CMRR, PSRR vs. Ambient Temperature.

Note: Unless otherwise indicated, $T_A = +25^\circ\text{C}$, $V_{DD} = +1.8\text{V}$ to $+5.5\text{V}$, $V_{SS} = \text{GND}$, $V_{CM} = V_{DD}/4$, $V_{OUT} = V_{DD}/2$, $V_L = V_{DD}/2$, $R_L = 10\text{ k}\Omega$ to V_L and $C_L = 30\text{ pF}$.

2.2 Other DC Voltages and Currents

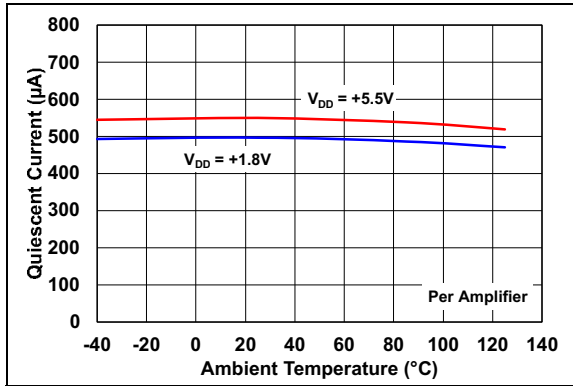

FIGURE 2-12: Quiescent Current vs. Ambient Temperature.

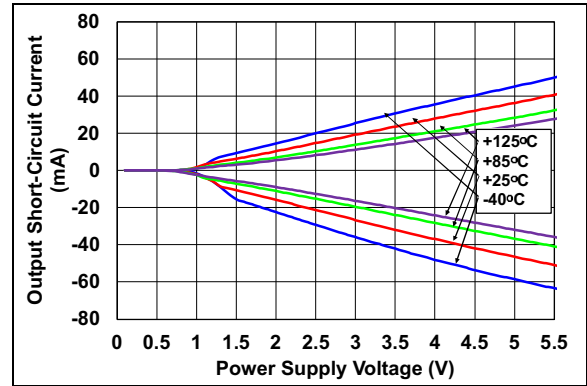

FIGURE 2-15: Output Short-Circuit Current vs. Power Supply Voltage.

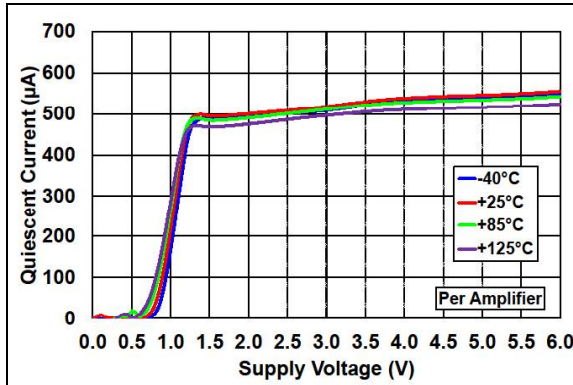

FIGURE 2-13: Quiescent Current vs. Power Supply Voltage.

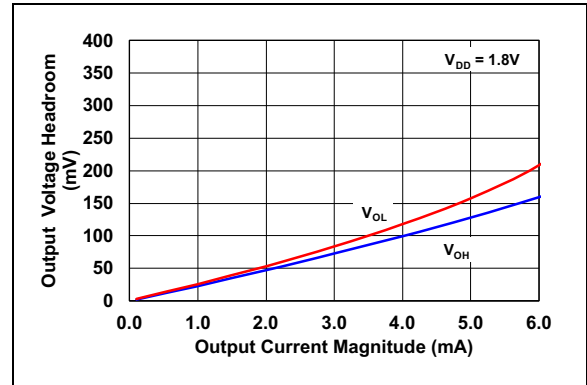

FIGURE 2-16: Output Voltage Headroom vs. Output Current.

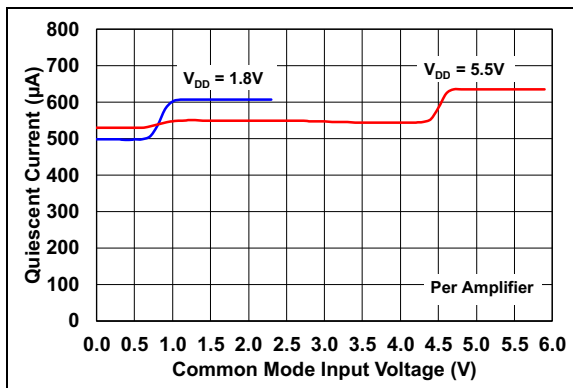

FIGURE 2-14: Quiescent Current vs. Common-Mode Input Voltage.

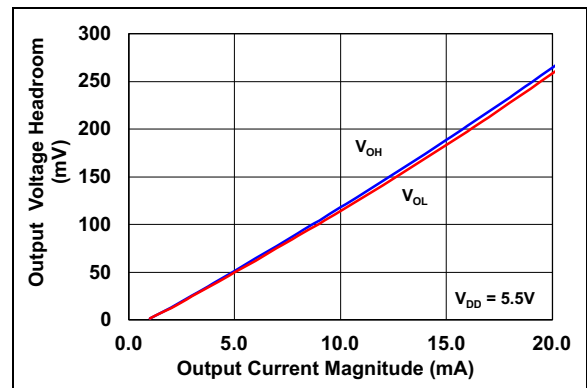

FIGURE 2-17: Output Voltage Headroom vs. Output Current.

MCP6486/6R/6U/7/9

Note: Unless otherwise indicated, $T_A = +25^\circ\text{C}$, $V_{DD} = +1.8\text{V}$ to $+5.5\text{V}$, $V_{SS} = \text{GND}$, $V_{CM} = V_{DD}/4$, $V_{OUT} = V_{DD}/2$, $V_L = V_{DD}/2$, $R_L = 10\text{ k}\Omega$ to V_L and $C_L = 30\text{ pF}$.

2.3 Frequency Response

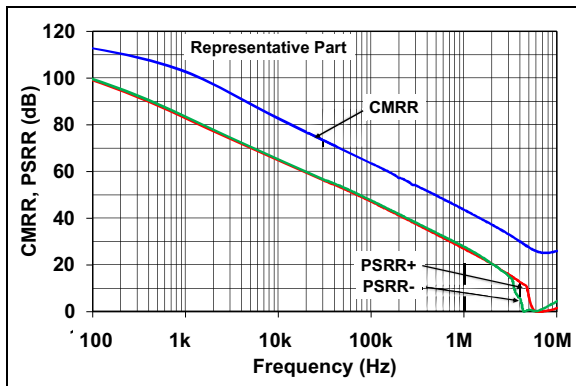

FIGURE 2-18: CMRR, PSRR vs. Frequency.

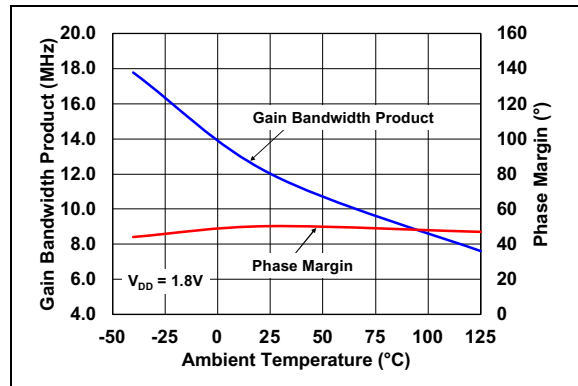

FIGURE 2-21: Gain Bandwidth Product, Phase Margin vs. Ambient Temperature.

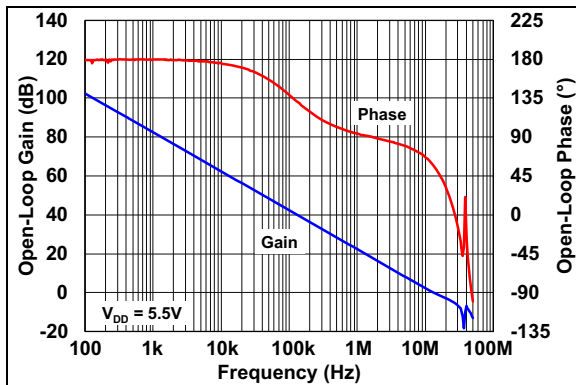

FIGURE 2-19: Open-Loop Gain, Phase vs. Frequency.

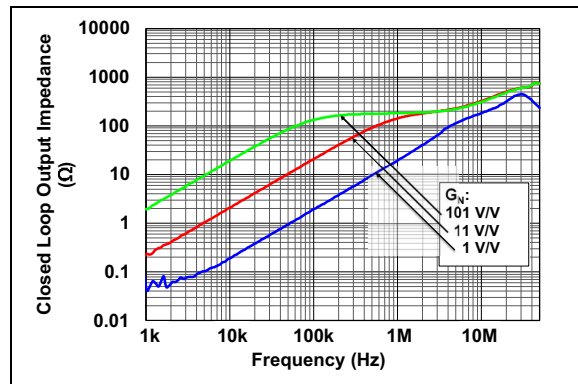

FIGURE 2-22: Closed-Loop Output Impedance vs. Frequency.

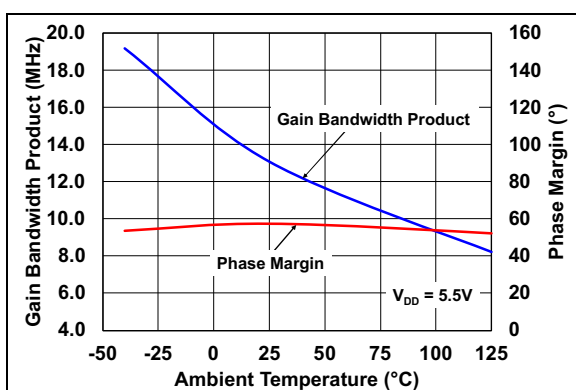

FIGURE 2-20: Gain Bandwidth Product, Phase Margin vs. Ambient Temperature.

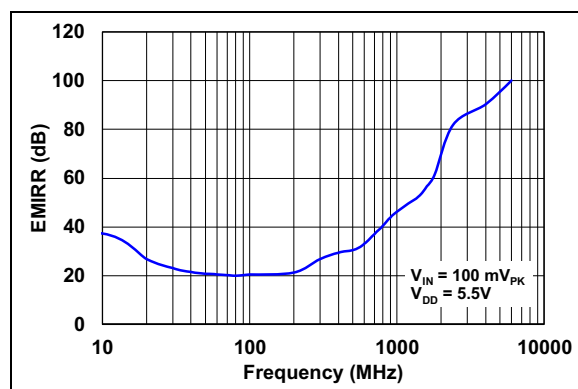

FIGURE 2-23: EMIRR vs. Frequency.

Note: Unless otherwise indicated, $T_A = +25^\circ\text{C}$, $V_{DD} = +1.8\text{V}$ to $+5.5\text{V}$, $V_{SS} = \text{GND}$, $V_{CM} = V_{DD}/4$, $V_{OUT} = V_{DD}/2$, $V_L = V_{DD}/2$, $R_L = 10\text{ k}\Omega$ to V_L and $C_L = 30\text{ pF}$.

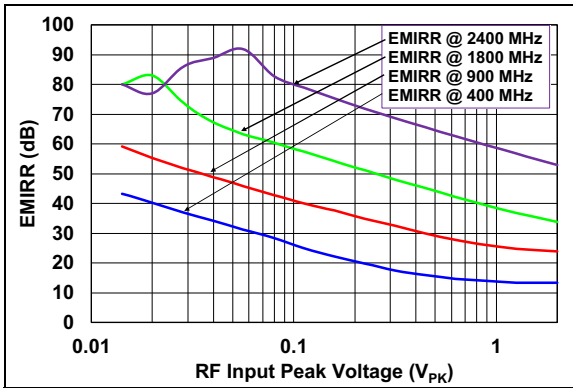

FIGURE 2-24: EMIRR vs. RF Input Peak-to-Peak Voltage.

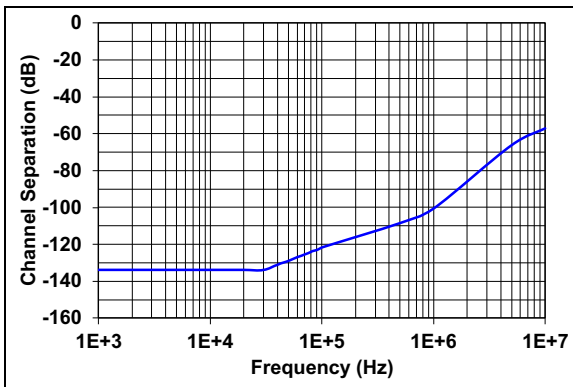

FIGURE 2-25: Channel Separation vs. Frequency.

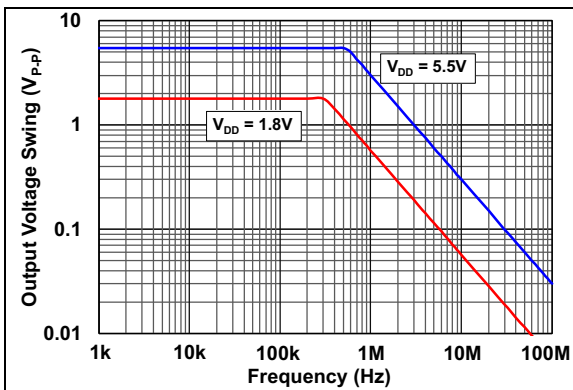

FIGURE 2-26: Maximum Output Voltage Swing vs. Frequency.

MCP6486/6R/6U/7/9

Note: Unless otherwise indicated, $T_A = +25^\circ\text{C}$, $V_{DD} = +1.8\text{V}$ to $+5.5\text{V}$, $V_{SS} = \text{GND}$, $V_{CM} = V_{DD}/4$, $V_{OUT} = V_{DD}/2$, $V_L = V_{DD}/2$, $R_L = 10\text{ k}\Omega$ to V_L and $C_L = 30\text{ pF}$.

2.4 Input Noise

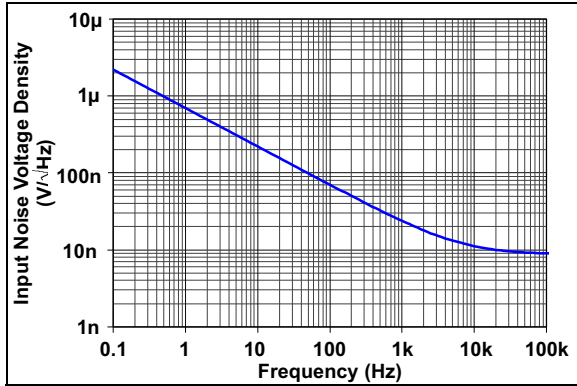

FIGURE 2-27: Input Noise Voltage Density vs. Frequency.

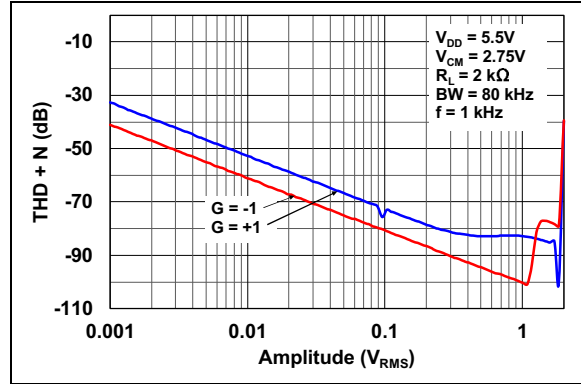

FIGURE 2-30: THD + N vs. Amplitude.

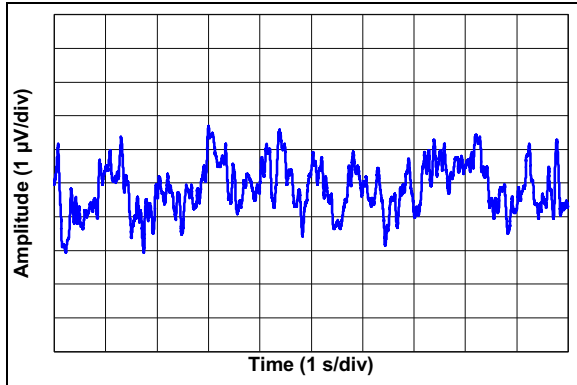

FIGURE 2-28: 0.1 Hz to 10 Hz Voltage Noise.

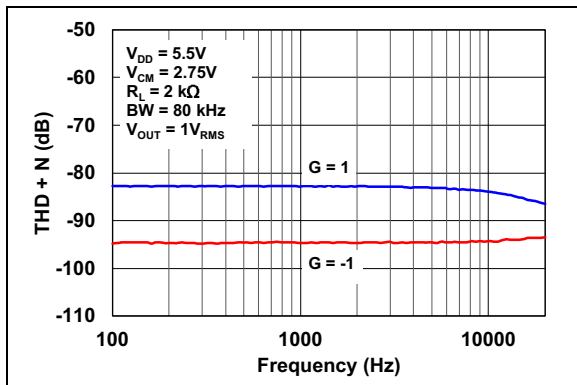

FIGURE 2-29: THD + N vs. Frequency.

Note: Unless otherwise indicated, $T_A = +25^\circ\text{C}$, $V_{DD} = +1.8\text{V}$ to $+5.5\text{V}$, $V_{SS} = \text{GND}$, $V_{CM} = V_{DD}/4$, $V_{OUT} = V_{DD}/2$, $V_L = V_{DD}/2$, $R_L = 10\text{ k}\Omega$ to V_L and $C_L = 30\text{ pF}$.

2.5 Time Response

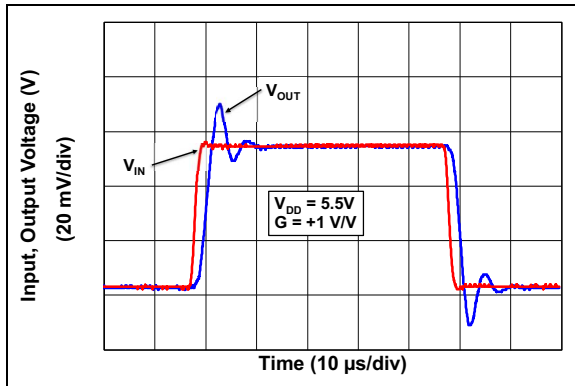

FIGURE 2-31: Small Signal Noninverting Pulse Response.

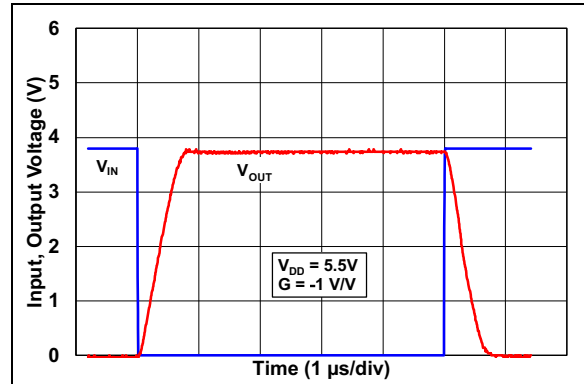

FIGURE 2-34: Large Signal Inverting Pulse Response.

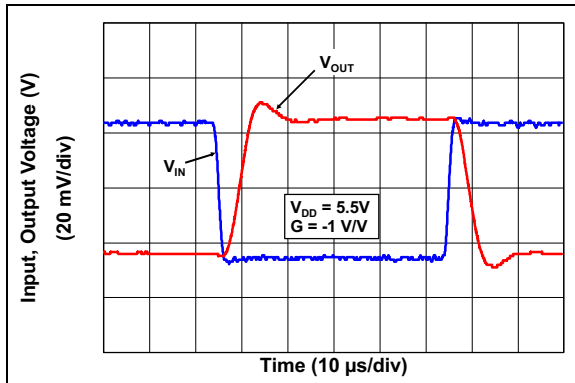

FIGURE 2-32: Small Signal Inverting Pulse Response.

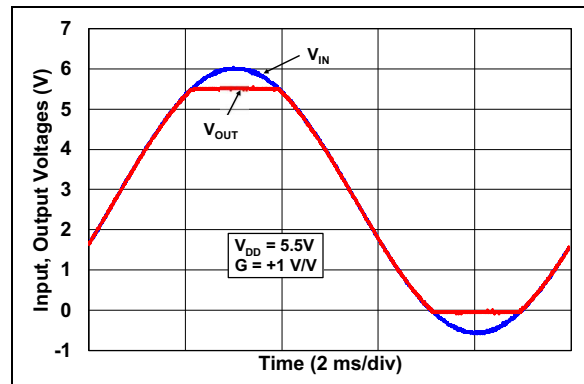

FIGURE 2-35: The MCP6486/6R/6U/7/9 Device Shows No Phase Reversal.

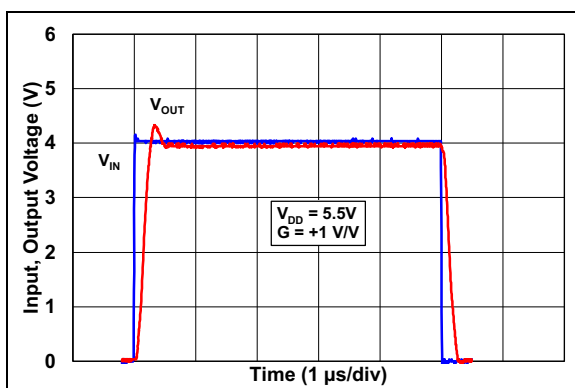

FIGURE 2-33: Large Signal Noninverting Pulse Response.

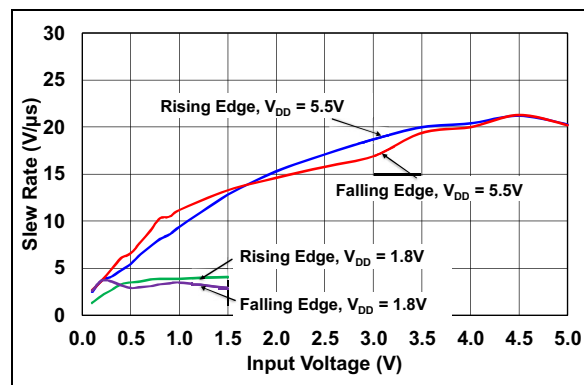

FIGURE 2-36: Slew Rate vs Input Voltage.

MCP6486/6R/6U/7/9

Note: Unless otherwise indicated, $T_A = +25^\circ\text{C}$, $V_{DD} = +1.8\text{V}$ to $+5.5\text{V}$, $V_{SS} = \text{GND}$, $V_{CM} = V_{DD}/4$, $V_{OUT} = V_{DD}/2$, $V_L = V_{DD}/2$, $R_L = 10\text{ k}\Omega$ to V_L and $C_L = 30\text{ pF}$.

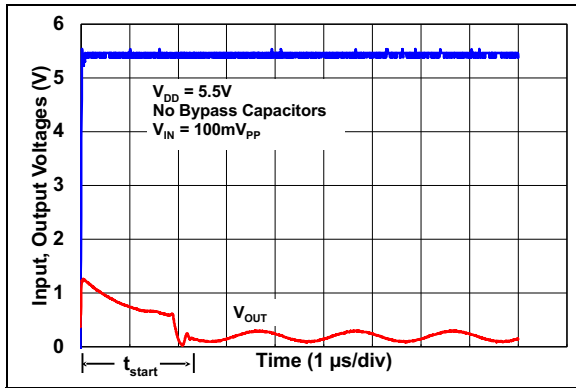

FIGURE 2-37: Start-Up Time.

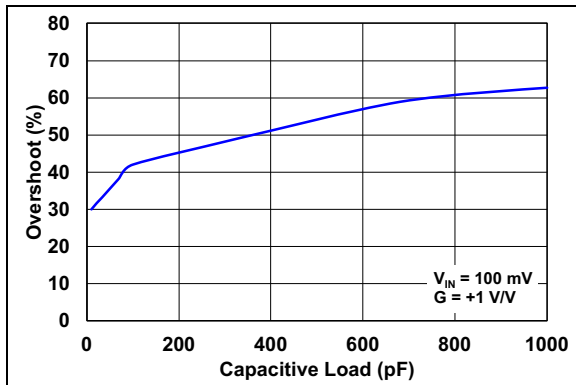

FIGURE 2-38: Overshoot vs. Capacitive Load. (Gain = +1).

3.0 PIN DESCRIPTIONS

Descriptions of the pins are listed in [Table 3-1](#), [Table 3-2](#), and [Table 3-3](#).

TABLE 3-1: PIN FUNCTION TABLE - SINGLES

MCP6486	MCP6486R	MCP6486U	Symbol	Description
5-Lead SC70, SOT-23	5-Lead SOT-23	5-Lead SC70, SOT-23		
1	1	4	V_{OUT}	Analog Output
2	5	2	V_{SS}	Negative Power Supply
3	3	1	V_{IN+}	Noninverting Input
4	4	3	V_{IN-}	Inverting Input
5	2	5	V_{DD}	Positive Power Supply

TABLE 3-2: PIN FUNCTION TABLE - DUALS

MCP6487	Symbol	Description
8-Lead MSOP, SOIC		
1	V_{OUTA}	Analog Output; Op Amp A
2	V_{INA-}	Inverting Input; Op Amp A
3	V_{INA+}	Noninverting Input; Op Amp A
4	V_{SS}	Negative Power Supply
5	V_{INB+}	Noninverting Input; Op Amp B
6	V_{INB-}	Inverting Input; Op Amp B
7	V_{OUTB}	Analog Output; Op Amp B
8	V_{DD}	Positive Power Supply

TABLE 3-3: PIN FUNCTION TABLE - QUADS

MCP6489	Symbol	Description
14-Lead TSSOP, SOIC		
1	V_{OUTA}	Analog Output; Op Amp A
2	V_{INA-}	Inverting Input; Op Amp A
3	V_{INA+}	Noninverting Input; Op Amp A
4	V_{DD}	Positive Power Supply
5	V_{INB+}	Noninverting Input; Op Amp B
6	V_{INB-}	Inverting Input; Op Amp B
7	V_{OUTB}	Analog Output; Op Amp B
8	V_{OUTC}	Analog Output; Op Amp C
9	V_{INC-}	Inverting Input; Op Amp C
10	V_{INC+}	Noninverting Input; Op Amp C
11	V_{SS}	Negative Power Supply
12	V_{IND+}	Noninverting Input; Op Amp D
13	V_{IND-}	Inverting Input; Op Amp D
14	V_{OUTD}	Analog Output; Op Amp D

MCP6486/6R/6U/7/9

3.1 Analog Outputs

The analog output pins (V_{OUTx}) are low-impedance voltage sources.

3.2 Analog Inputs

The noninverting and inverting inputs (V_{INx+} , V_{INx-}) are high-impedance CMOS inputs with low bias currents.

3.3 Power Supply Pins (V_{SS} , V_{DD})

The positive power supply (V_{DD}) is 1.8V to 5.5V higher than the negative power supply (V_{SS}). For normal operation, the other pins are at voltages between V_{SS} and V_{DD} .

Typically, these parts are used in a single (positive) supply configuration. In this case, V_{SS} is connected to ground and V_{DD} is connected to the supply. V_{DD} needs bypass capacitors.

4.0 APPLICATION INFORMATION

The MCP6486/6R/6U/7/9 operational amplifier is unity gain stable and suitable for a wide range of general purpose applications.

4.1 Rail-to-Rail Input

4.1.1 PHASE REVERSAL

The MCP6486/6R/6U/7/9 op amp is designed to prevent phase reversal, when the input pins exceed the supply voltages. Figure 2-35 shows the input voltage exceeding the supply voltage with no phase reversal.

4.1.2 INPUT VOLTAGE LIMITS

In order to prevent damage and/or improper operation of the amplifier, the circuit must limit the voltages at the input pins (see Section 1.1, Absolute Maximum Ratings†).

The Electrostatic Discharge (ESD) protection on the inputs can be depicted as shown in Figure 4-1. This structure was chosen to protect the input transistors against many, but not all, overvoltage conditions and to minimize the Input Bias (I_B) current.

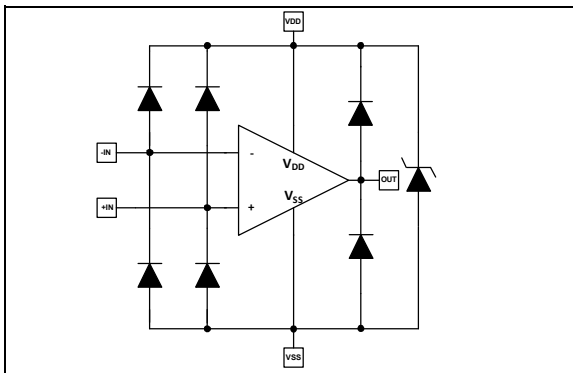

FIGURE 4-1: Simplified Analog Input ESD Structures.

The input ESD diodes clamp the inputs when they try to go more than one diode drop below V_{SS} . They also clamp any voltages that go well above V_{DD} ; their breakdown voltage is high enough to allow normal operation. At 0.5V above V_{DD} or below V_{SS} , the input currents are typically less than 5 mA. Very fast ESD events that meet the specifications are limited so that damage does not occur.

4.1.3 INPUT CURRENT LIMITS

In order to prevent damage and/or improper operation of the amplifier, the circuit must limit the currents into the input pins (see Section 1.1, Absolute Maximum Ratings†).

Figure 4-2 shows one approach to protecting these inputs. The resistors R_1 and R_2 limit the possible currents in or out of the input pins through the ESD diodes to either V_{DD} or V_{SS} .

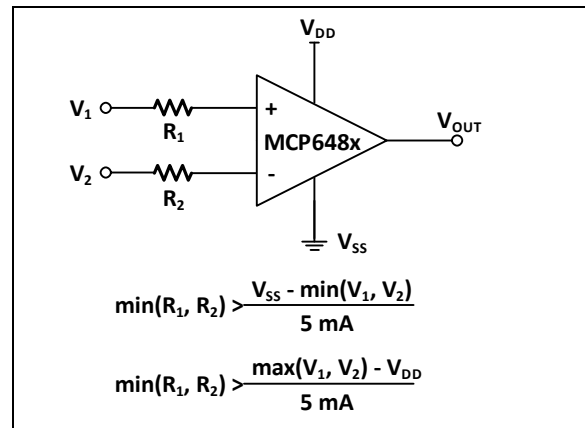

FIGURE 4-2: Protecting the Analog Inputs.

MCP6486/6R/6U/7/9

4.1.4 NORMAL OPERATION

The input stage of the MCP6486/6R/6U/7/9 op amp uses two differential input stages in parallel. One operates at a low Common mode input voltage (V_{CM}), while the other operates at a high V_{CM} . With this topology, the device operates with a V_{CM} up to 300 mV above V_{DD} and 300 mV below V_{SS} . The input offset voltage is measured at $V_{CM} = V_{SS} - 0.3V$ and $V_{DD} + 0.3V$ to ensure proper operation.

The transition between the input stages occurs when V_{CM} is near $V_{DD} - 0.9V$ (see Figures 2-3 and 2-4). For the best distortion performance and gain linearity, with noninverting gains, avoid this region of operation.

4.2 Rail-to-Rail Output

The output voltage range of the MCP6486/6R/6U/7/9 op amp is 0.003V (typical) and 5.496V (typical) when $R_L = 10\text{ k}\Omega$ is connected to $V_{DD}/2$ and $V_{DD} = 5.5V$. Refer to Figures 2-16 and 2-17 for more information.

4.3 Start-up

The MCP6486/6R/6U/7/9 family of parts quickly controls the output when power (V_{DD}) is initially applied to the device (start-up). Bypass capacitors are removed during the start-up testing to minimize the inrush currents (see Figure 4-3). When the op amp is controlled and is off, the output impedance is high and V_{OUT} is the input sine wave; this is used as the start-up time.

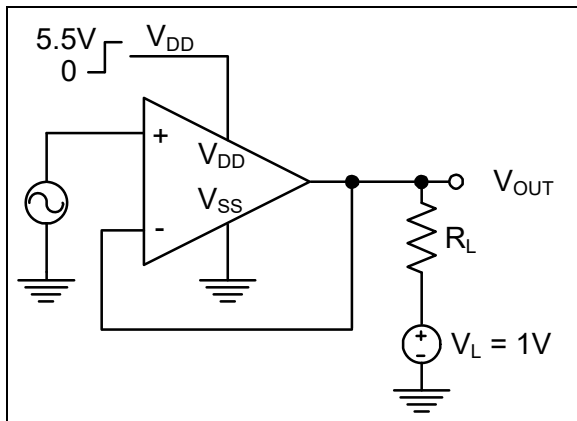

FIGURE 4-3: Start-Up Test Circuit.

Figure 4-4 shows the input voltage (blue line) for the MCP6487 and the output voltage (red line). When power is first applied to the MCP6487, the output is turned off (Point A) and is driven by the load. After 2.3 μs (typical), the output is turned on (Point B) and V_{OUT} follows the input sine wave.

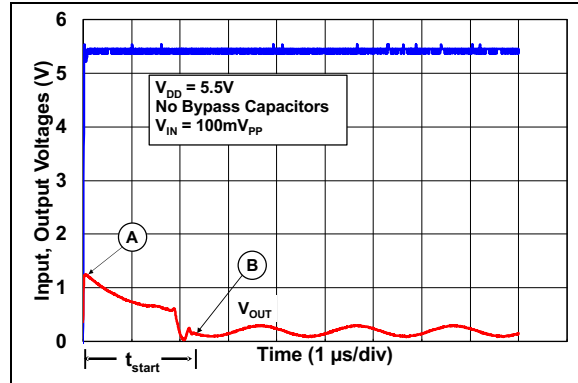

FIGURE 4-4: Start-Up Test Waveforms.

4.4 Capacitive Loads

Driving large capacitive loads can cause stability problems for voltage feedback op amps. As the load capacitance increases, the feedback loop's phase margin decreases, and the closed-loop bandwidth is reduced. This produces gain peaking in the frequency response, with overshoot and ringing in the step response. While a unity-gain buffer ($G = +1\text{ V/V}$) is the most sensitive to the capacitive loads, all gains show the same general behavior.

When driving large capacitive loads with the MCP6486/6R/6U/7/9 op amp, a small series resistor at the output (R_{ISO} in Figure 4-5) improves the feedback loop's phase margin (stability) by making the output load resistive at higher frequencies. The bandwidth will be generally lower than the bandwidth with no capacitance load.

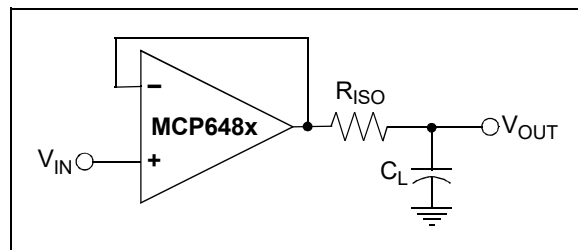

FIGURE 4-5: Output Resistor, R_{ISO} Stabilizes Large Capacitive Loads.

4.5 Supply Bypass

The MCP6486/6R/6U/7/9 op amp's power supply pin (V_{DD} for single-supply) should have a local bypass capacitor (i.e., 0.01 μF to 0.1 μF) within 2 mm for good high-frequency performance. It can use a bulk capacitor (i.e., 1 μF or larger) within 100 mm to provide large, slow currents. This bulk capacitor can be shared with other analog parts.

4.6 PCB Surface Leakage

In applications where low input bias current is critical, the Printed Circuit Board (PCB) surface leakage effects need to be considered. Surface leakage is caused by humidity, dust or other contamination on the board. Under low-humidity conditions, a typical resistance between nearby traces is $10^{12}\Omega$. A 5V difference would cause 5 pA of current to flow, which is greater than the MCP6486/6R/6U/7/9's bias current at +25°C (± 1 pA, typical).

The easiest way to reduce surface leakage is to use a guard ring around sensitive pins (or traces). The guard ring is biased at the same voltage as the sensitive pin. An example of this type of layout is shown in Figure 4-6.

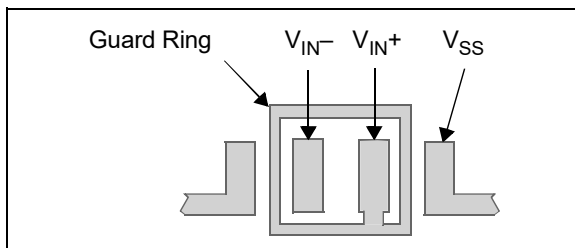

FIGURE 4-6: Example Guard Ring Layout for Inverting Gain.

1. Noninverting Gain and Unity-Gain Buffer:
 - a) Connect the noninverting pin (V_{IN+}) to the input with a wire that does not touch the PCB surface.
 - b) Connect the guard ring to the inverting input pin (V_{IN-}). This biases the guard ring to the Common mode input voltage.
2. Inverting Gain and Transimpedance Gain Amplifiers (convert current to voltage, such as photo detectors):
 - a) Connect the guard ring to the noninverting input pin (V_{IN+}). This biases the guard ring to the same reference voltage as the op amp (e.g., $V_{DD}/2$ or ground).
 - b) Connect the inverting pin (V_{IN-}) to the input with a wire that does not touch the PCB surface.

4.7 Unused Op Amps

An unused op amp in a dual (MCP6487) or quad (MCP6489) package should be configured as shown in Figure 4-7. These circuits prevent the output from toggling and causing crosstalk. Circuit A sets the op amp at its minimum noise gain. The resistor divider produces any desired reference voltage within the output voltage range of the op amp; the op amp buffers that reference voltage. Circuit B uses the minimum number of components.

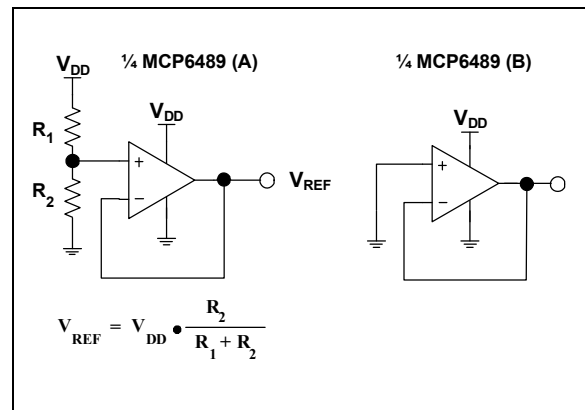

FIGURE 4-7: Unused Op Amps.

4.8 Electromagnetic Interference Rejection Ratio (EMIRR) Definitions

The electromagnetic interference (EMI) is the disturbance that affects an electrical circuit due to either electromagnetic induction or electromagnetic radiation emitted from an external source.

The parameter which describes the EMI robustness of an op amp is the Electromagnetic Interference Rejection Ratio (EMIRR). It quantitatively describes the effect that a Radio Frequency (RF) interfering signal has on op amp performance. Internal passive filters make EMIRR better, compared with older parts. This means that, with good PCB layout techniques, the EMC performance should be better.

EMIRR is defined in Equation 4-1.

EQUATION 4-1:

$$EMIRR(dB) = 20 \times \log\left(\frac{V_{RF}}{\Delta V_{OS}}\right)$$

Where:

- V_{RF} = Peak Amplitude of RF Interfering Signal (V_{PK})
- ΔV_{OS} = Input Offset Voltage Shift (V)

MCP6486/6R/6U/7/9

4.9 Application Circuits

4.9.1 MULTIPLE FEEDBACK LOW-PASS FILTER

The MCP6486/6R/6U/7/9 Op Amp can be used in active-filter applications. Figure 4-8 shows an inverting, third-order, multiple feedback low-pass filter that can be used as an anti-aliasing filter.

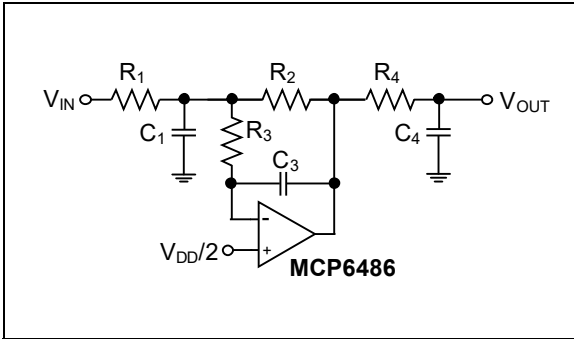

FIGURE 4-8: Multiple Feedback Low-Pass Filter.

4.9.2 PHOTODIODE AMPLIFIER

Figure 4-9 shows a photodiode biased in the photovoltaic mode for high precision. The resistor R converts the diode current I_D to the voltage V_{OUT} . The capacitor is used to limit the bandwidth or to stabilize the circuit against the diode's capacitance.

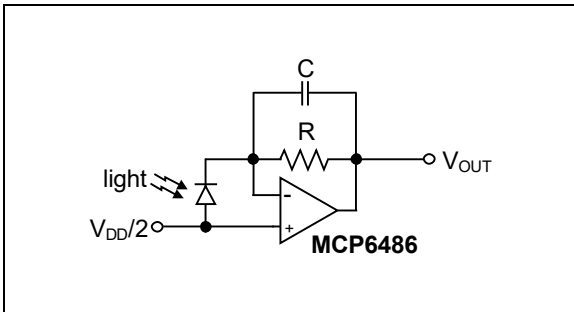

FIGURE 4-9: Photodiode Amplifier.

5.0 DESIGN AIDS

Microchip Technology Inc. provides the basic design tools needed for the MCP6486/6R/6U/7/9 op amp.

5.1 Microchip Advanced Part Selector (MAPS)

MAPS is a software tool that helps semiconductor professionals efficiently identify the Microchip devices that fit a particular design requirement. Available at no cost from the Microchip website at www.microchip.com/maps, MAPS is an overall selection tool for Microchip's product portfolio that includes Analog, Memory, MCUs and DSCs. Using this tool, you can define a filter to sort features for a parametric search of devices and export side-by-side technical comparison reports. Helpful links are also provided for data sheets, purchase and sampling of Microchip parts.

5.2 Analog Demonstration and Evaluation Boards

Microchip offers a broad spectrum of Analog Demonstration and Evaluation Boards that are designed to help you achieve faster time to market. For a complete listing of these boards and their corresponding user's guides and technical information, visit the Microchip web site at www.microchipdirect.com.

Some boards that are especially useful are:

- MCP6XXX Amplifier Evaluation Board 2 (P/N DS51668)
- MCP6XXX Amplifier Evaluation Board 3 (P/N DS51673)
- 8-Pin SOIC/MSOP/TSSOP/DIP Evaluation Board (P/N SOIC8EV)
- 5/6-Pin SOT-23 Evaluation Board (P/N VSUPEV2)
- 14-Pin SOIC/TSSOP/DIP Evaluation Board (P/N SOIC14EV)

5.3 Application Notes

The following Microchip Analog Design Note and Application Notes are available on the Microchip web site at www.microchip.com/appnotes, and are recommended as supplemental reference resources.

- **ADN003** – “*Select the Right Operational Amplifier for your Filtering Circuits*”, DS21821
- **AN722** – “*Operational Amplifier Topologies and DC Specifications*”, DS00722
- **AN723** – “*Operational Amplifier AC Specifications and Applications*”, DS00723
- **AN884** – “*Driving Capacitive Loads With Op Amps*”, DS00884
- **AN990** – “*Analog Sensor Conditioning Circuits – An Overview*”, DS00990
- **AN1177** – “*Op Amp Precision Design: DC Errors*”, DS01177
- **AN1228** – “*Op Amp Precision Design: Random Noise*”, DS01228
- **AN1258** – “*Op Amp Precision Design: PCB Layout Techniques*”, DS01258

These application notes and others are listed in the design guide:

- “*Signal Chain Design Guide*”, DS21825

MCP6486/6R/6U/7/9

6.0 PACKAGING INFORMATION

6.1 Package Marking Information

5-Lead SC70 (MCP6486/6U)

Example:

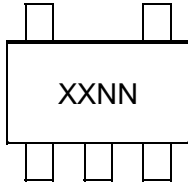

Device	Marking
MCP6486	HANN
MCP6486U	HBNN

Note: Applies to 5-Lead SC-70.

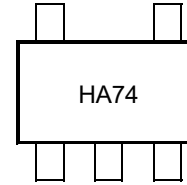

5-Lead SOT-23 (MCP6486/6U/6R)

Example:

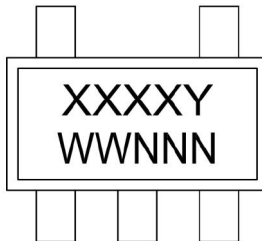

Device	Marking
MCP6486	AAD1
MCP6486U	AAD2
MCP6486R	AAD3

Note: Applies to 5-Lead SOT-23.

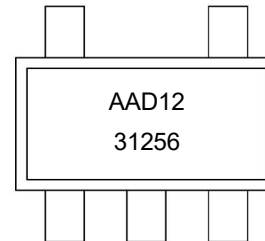

Legend:	XX...X	Customer-specific information
	Y	Year code (last digit of calendar year)
	YY	Year code (last 2 digits of calendar year)
	WW	Week code (week of January 1 is week '01')
	NNN	Alphanumeric traceability code
	(e3)	Pb-free JEDEC designator for Matte Tin (Sn)
	*	This package is Pb-free. The Pb-free JEDEC designator (e3) can be found on the outer packaging for this package.

Note: In the event the full Microchip part number cannot be marked on one line, it will be carried over to the next line, thus limiting the number of available characters for customer-specific information.

MCP6486/6R/6U/7/9

Package Marking Information (Continued)

8-Lead SOIC (150 mil) (MCP6487)

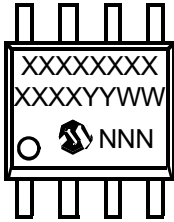

Example:



8-Lead MSOP



Example:



14-Lead SOIC (150 mil) (MCP6489)

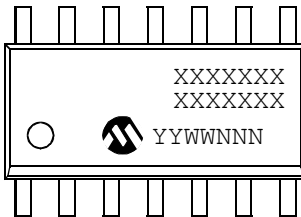

Example:

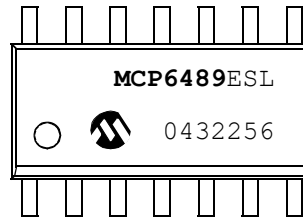

OR

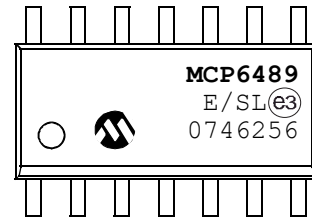

14-Lead TSSOP (MCP6489)

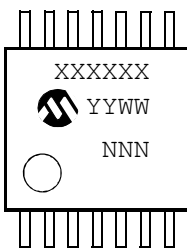

Example:

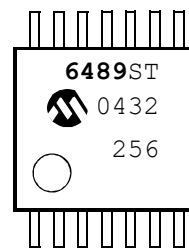

OR

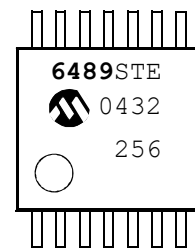

MCP6486/6R/6U/7/9

5-Lead Plastic Small Outline Transistor (LT) [SC70]

Note: For the most current package drawings, please see the Microchip Packaging Specification located at <http://www.microchip.com/packaging>

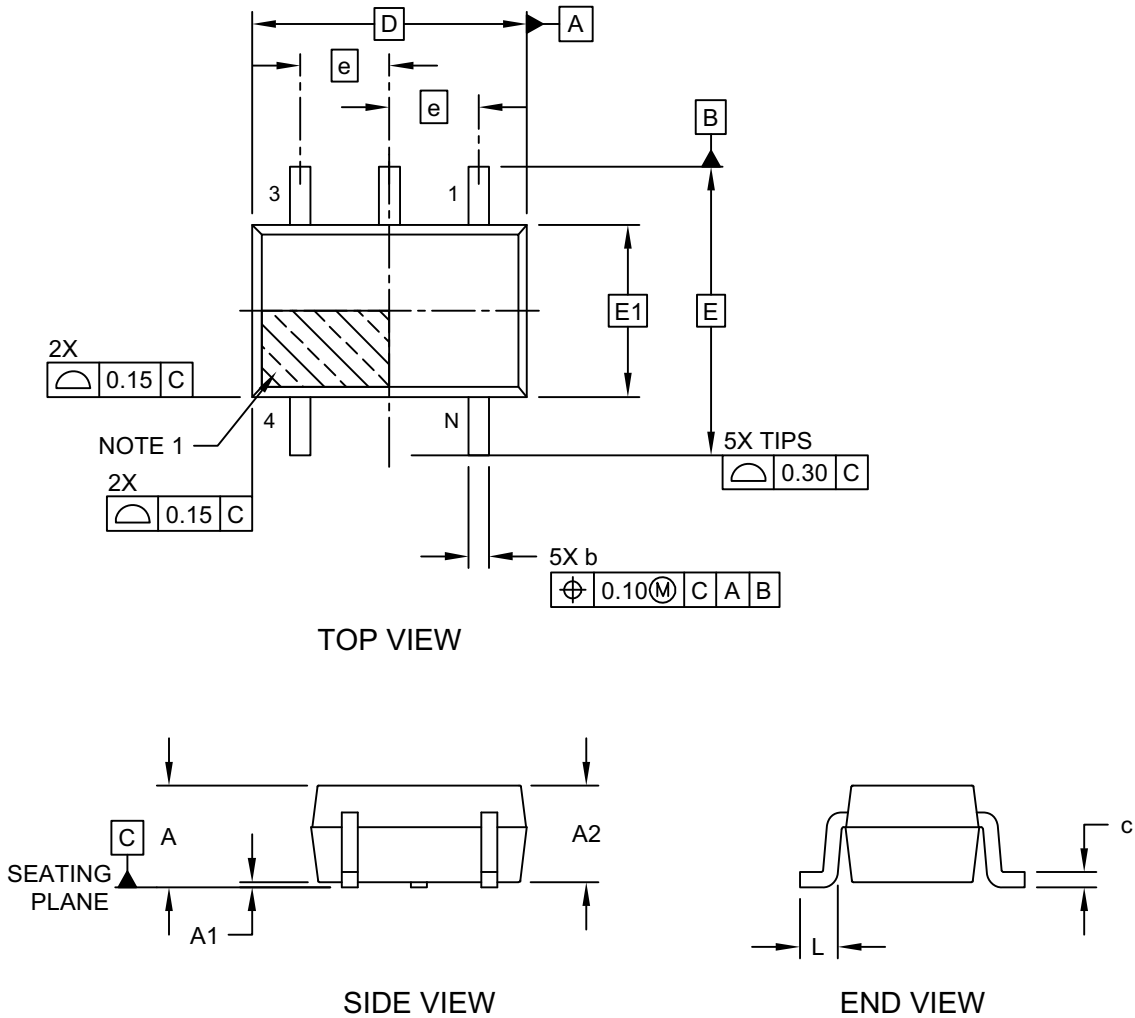

Microchip Technology Drawing C04-061-LT Rev E Sheet 1 of 2

5-Lead Plastic Small Outline Transistor (LT) [SC70]

Note: For the most current package drawings, please see the Microchip Packaging Specification located at <http://www.microchip.com/packaging>

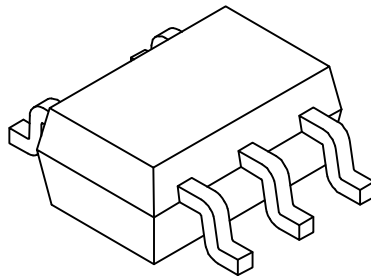

Units		MILLIMETERS		
Dimension Limits		MIN	NOM	MAX
Number of Pins	N	5		
Pitch	e	0.65 BSC		
Overall Height	A	0.80	-	1.10
Standoff	A1	0.00	-	0.10
Molded Package Thickness	A2	0.80	-	1.00
Overall Length	D	2.00 BSC		
Overall Width	E	2.10 BSC		
Molded Package Width	E1	1.25 BSC		
Terminal Width	b	0.15	-	0.40
Terminal Length	L	0.10	0.20	0.46
Lead Thickness	c	0.08	-	0.26

Notes:

1. Pin 1 visual index feature may vary, but must be located within the hatched area.
2. Dimensions D and E1 do not include mold flash or protrusions. Mold flash or protrusions shall not exceed 0.15mm per side.
3. Dimensioning and tolerancing per ASME Y14.5M

BSC: Basic Dimension. Theoretically exact value shown without tolerances.

REF: Reference Dimension, usually without tolerance, for information purposes only.

Microchip Technology Drawing C04-061-LT Rev E Sheet 2 of 2

MCP6486/6R/6U/7/9

5-Lead Plastic Small Outline Transistor (LT) [SC70]

Note: For the most current package drawings, please see the Microchip Packaging Specification located at <http://www.microchip.com/packaging>

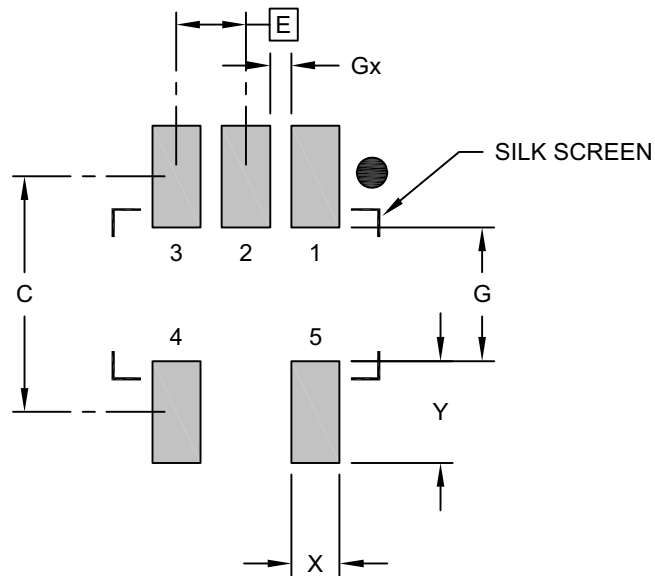

RECOMMENDED LAND PATTERN

Dimension Limits	Units	MILLIMETERS		
		MIN	NOM	MAX
Contact Pitch	E	0.65 BSC		
Contact Pad Spacing	C		2.20	
Contact Pad Width	X			0.45
Contact Pad Length	Y			0.95
Distance Between Pads	G	1.25		
Distance Between Pads	Gx	0.20		

Notes:

1. Dimensioning and tolerancing per ASME Y14.5M

BSC: Basic Dimension. Theoretically exact value shown without tolerances.

Microchip Technology Drawing No. C04-2061-LT Rev E

MCP6486/6R/6U/7/9

8-Lead Plastic Small Outline (SN) - Narrow, 3.90 mm (.150 In.) Body [SOIC]

Note: For the most current package drawings, please see the Microchip Packaging Specification located at <http://www.microchip.com/packaging>

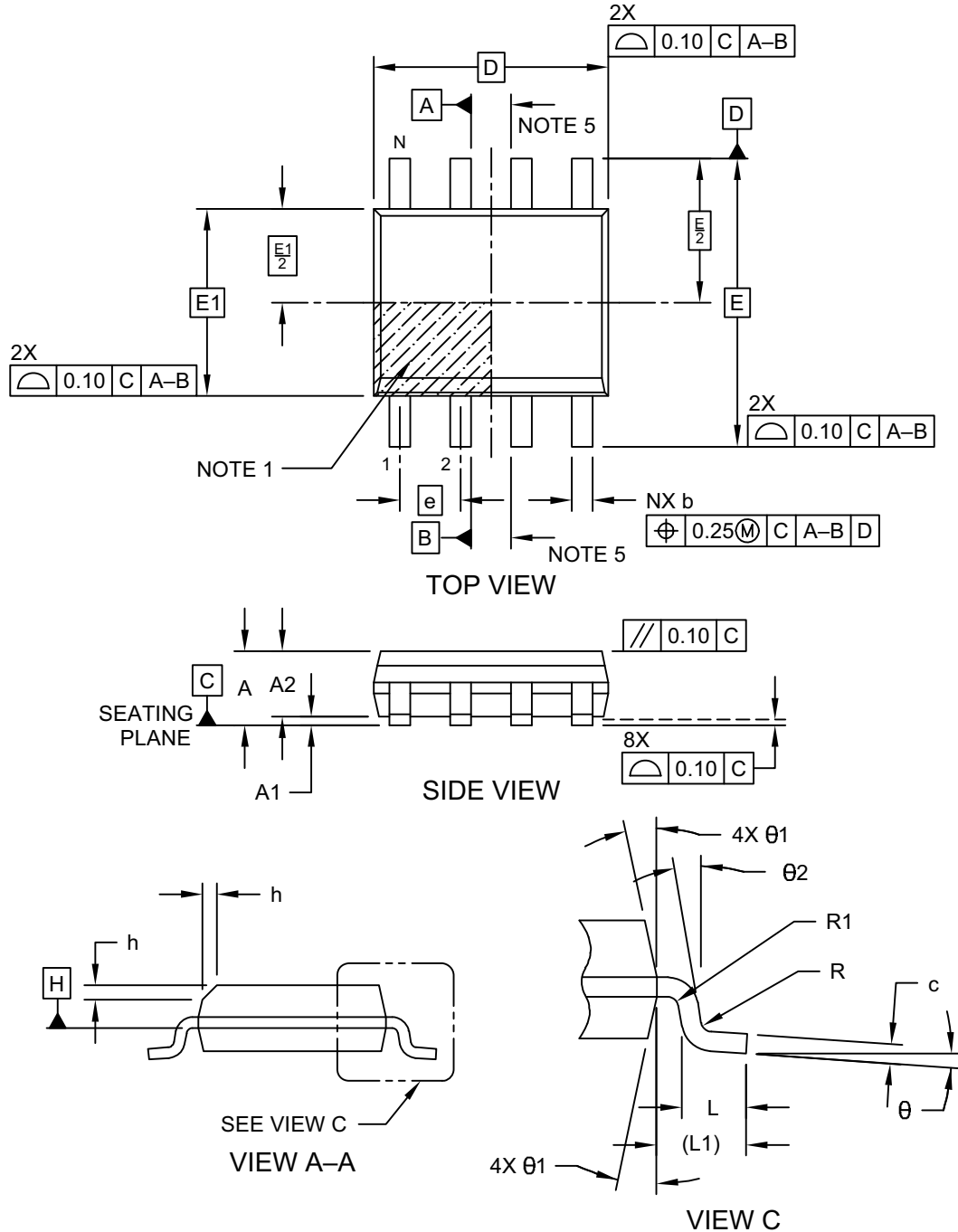

Microchip Technology Drawing No. C04-057-SN Rev H Sheet 1 of 2

MCP6486/6R/6U/7/9

8-Lead Plastic Small Outline (SN) - Narrow, 3.90 mm (.150 In.) Body [SOIC]

Note: For the most current package drawings, please see the Microchip Packaging Specification located at <http://www.microchip.com/packaging>

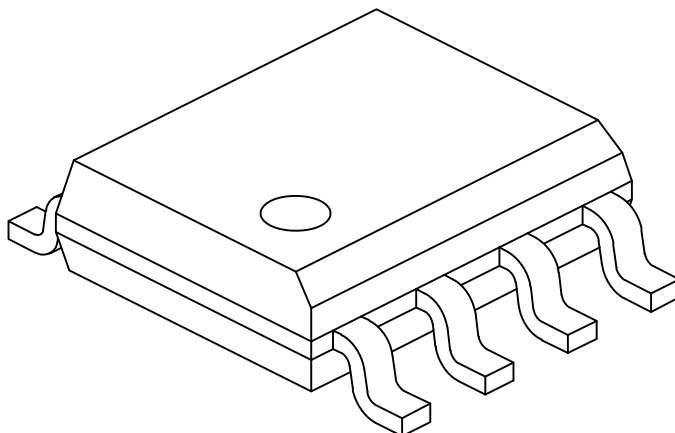

Dimension Limits	Units	MILLIMETERS		
		MIN	NOM	MAX
Number of Pins	N	8		
Pitch	e	1.27 BSC		
Overall Height	A	–	–	1.75
Molded Package Thickness	A2	1.25	–	–
Standoff §	A1	0.10	–	0.25
Overall Width	E	6.00 BSC		
Molded Package Width	E1	3.90 BSC		
Overall Length	D	4.90 BSC		
Chamfer (Optional)	h	0.25	–	0.50
Foot Length	L	0.40	–	1.27
Footprint	L1	1.04 REF		
Lead Thickness	c	0.17	–	0.25
Lead Width	b	0.31	–	0.51
Lead Bend Radius	R	0.07	–	–
Lead Bend Radius	R1	0.07	–	–
Foot Angle	θ	0°	–	8°
Mold Draft Angle	θ1	5°	–	15°
Lead Angle	θ2	0°	–	8°

Notes:

1. Pin 1 visual index feature may vary, but must be located within the hatched area.
2. § Significant Characteristic
3. Dimensions D and E1 do not include mold flash or protrusions. Mold flash or protrusions shall not exceed 0.15mm per side.
4. Dimensioning and tolerancing per ASME Y14.5M
BSC: Basic Dimension. Theoretically exact value shown without tolerances.
REF: Reference Dimension, usually without tolerance, for information purposes only.
5. Datums A & B to be determined at Datum H.

Microchip Technology Drawing No. C04-057-SN Rev H Sheet 2 of 2

MCP6486/6R/6U/7/9

8-Lead Plastic Small Outline (SN) - Narrow, 3.90 mm (.150 In.) Body [SOIC]

Note: For the most current package drawings, please see the Microchip Packaging Specification located at <http://www.microchip.com/packaging>

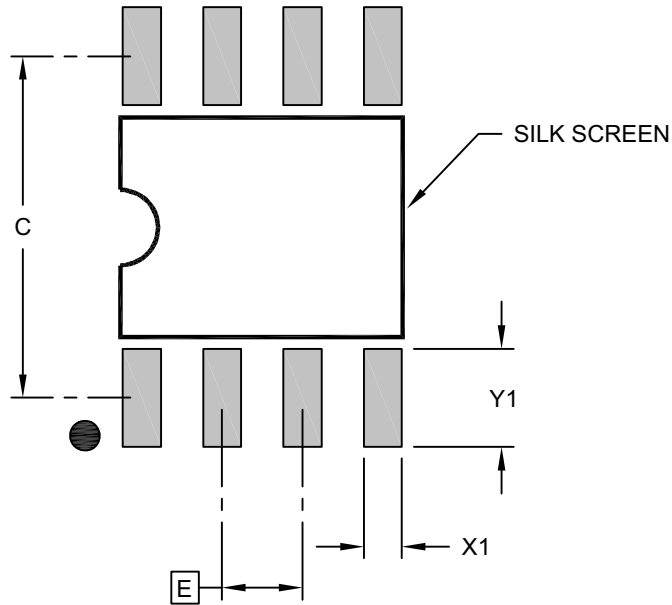

RECOMMENDED LAND PATTERN

Dimension Limits	Units	MILLIMETERS		
		MIN	NOM	MAX
Contact Pitch	E	1.27 BSC		
Contact Pad Spacing	C		5.40	
Contact Pad Width (X8)	X1			0.60
Contact Pad Length (X8)	Y1			1.55

Notes:

1. Dimensioning and tolerancing per ASME Y14.5M

BSC: Basic Dimension. Theoretically exact value shown without tolerances.

Microchip Technology Drawing C04-2057-SN Rev H

MCP6486/6R/6U/7/9

8-Lead Plastic Micro Small Outline Package (MS) - 3x3 mm Body [MSOP]

Note: For the most current package drawings, please see the Microchip Packaging Specification located at <http://www.microchip.com/packaging>

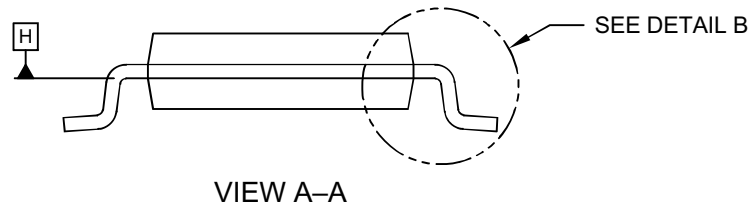
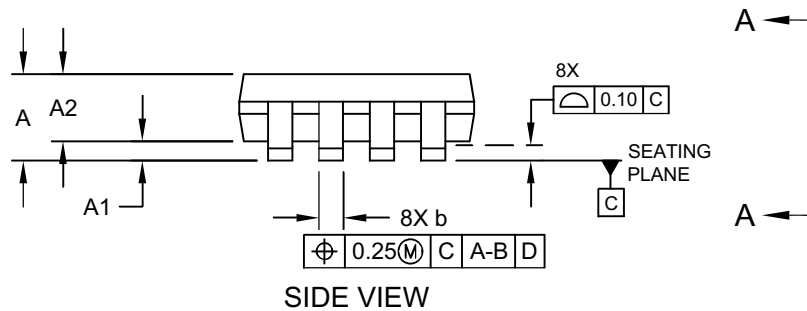
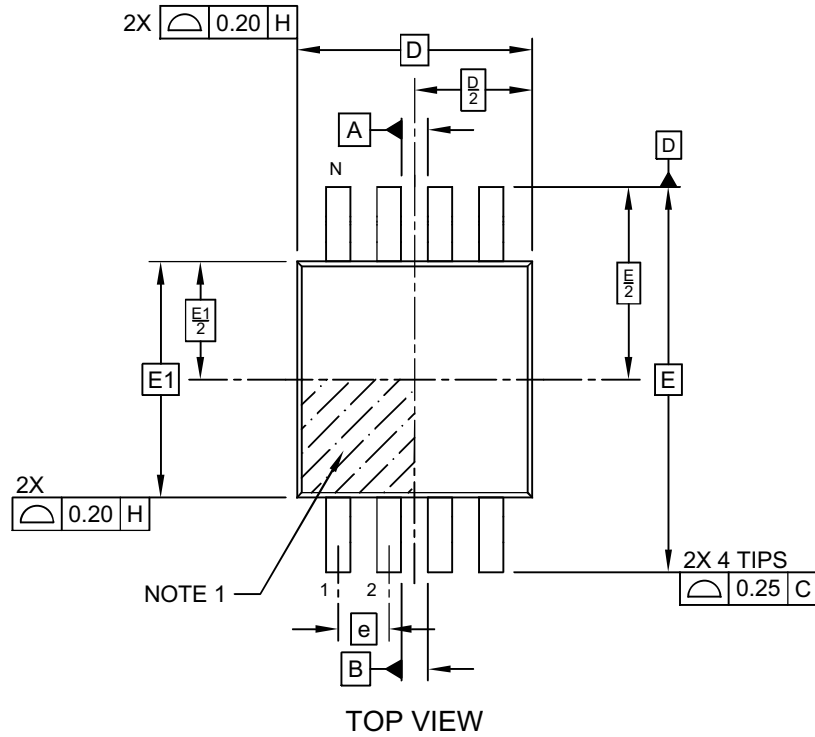

Microchip Technology Drawing C04-111-MS Rev F Sheet 1 of 2

8-Lead Plastic Micro Small Outline Package (MS) - 3x3 mm Body [MSOP]

Note: For the most current package drawings, please see the Microchip Packaging Specification located at <http://www.microchip.com/packaging>

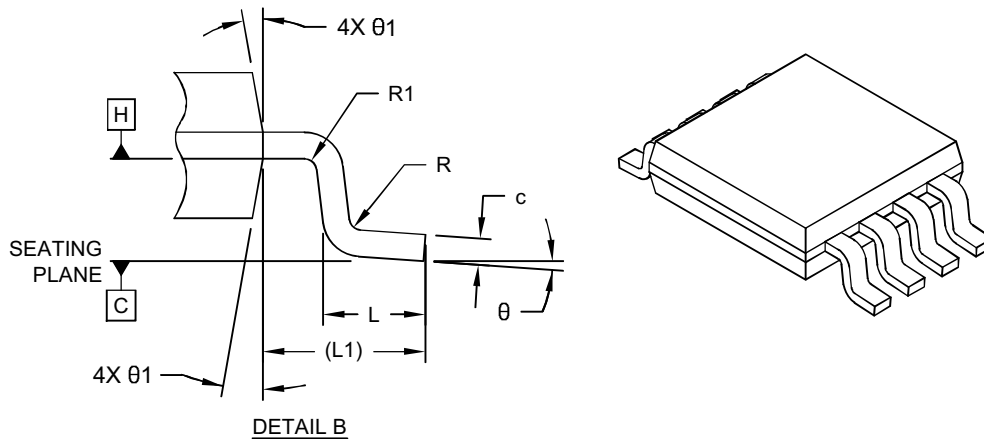

Dimension Limits	Units	MILLIMETERS		
		MIN	NOM	MAX
Number of Terminals	N	8		
Pitch	e	0.65 BSC		
Overall Height	A	–	–	1.10
Standoff	A1	0.00	–	0.15
Molded Package Thickness	A2	0.75	0.85	0.95
Overall Length	D	3.00 BSC		
Overall Width	E	4.90 BSC		
Molded Package Width	E1	3.00 BSC		
Terminal Width	b	0.22	–	0.40
Terminal Thickness	c	0.08	–	0.23
Terminal Length	L	0.40	0.60	0.80
Footprint	L1	0.95 REF		
Lead Bend Radius	R	0.07	–	–
Lead Bend Radius	R1	0.07	–	–
Foot Angle	θ	0°	–	8°
Mold Draft Angle	θ1	5°	–	15°

Notes:

- Pin 1 visual index feature may vary, but must be located within the hatched area.
- Dimensions D and E1 do not include mold flash or protrusions. Mold flash or protrusions shall not exceed 0.15mm per side.
- Dimensioning and tolerancing per ASME Y14.5M
 BSC: Basic Dimension. Theoretically exact value shown without tolerances.
 REF: Reference Dimension, usually without tolerance, for information purposes only.

Microchip Technology Drawing C04-111-MS Rev F Sheet 2 of 2

MCP6486/6R/6U/7/9

8-Lead Plastic Micro Small Outline Package (MS) - 3x3 mm Body [MSOP]

Note: For the most current package drawings, please see the Microchip Packaging Specification located at <http://www.microchip.com/packaging>

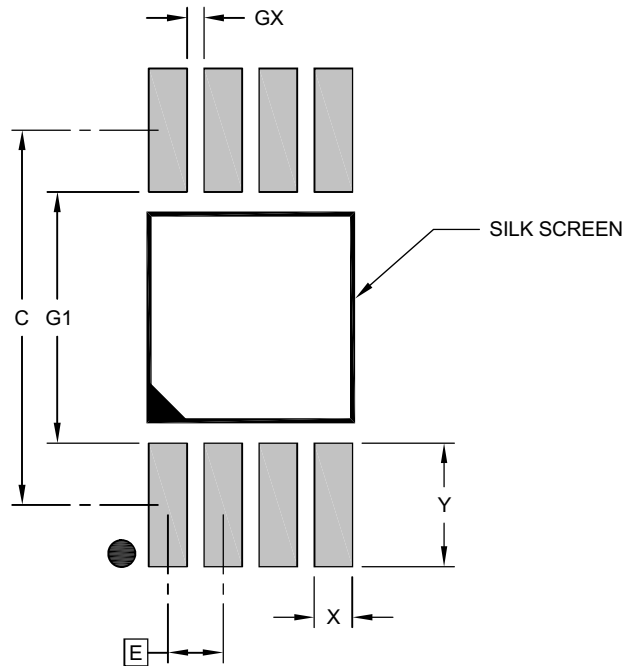

RECOMMENDED LAND PATTERN

Dimension Limits	Units	MILLIMETERS		
		MIN	NOM	MAX
Contact Pitch	E	0.65 BSC		
Contact Pad Spacing	C		4.40	
Contact Pad Width (X8)	X			0.45
Contact Pad Length (X8)	Y			1.45
Contact Pad to Contact Pad (X4)	G1	2.95		
Contact Pad to Contact Pad (X6)	GX	0.20		

Notes:

1. Dimensioning and tolerancing per ASME Y14.5M

BSC: Basic Dimension. Theoretically exact value shown without tolerances.

Microchip Technology Drawing C04-2111-MS Rev F

MCP6486/6R/6U/7/9

14-Lead Plastic Small Outline (SL) - Narrow, 3.90 mm Body [SOIC]

Note: For the most current package drawings, please see the Microchip Packaging Specification located at <http://www.microchip.com/packaging>

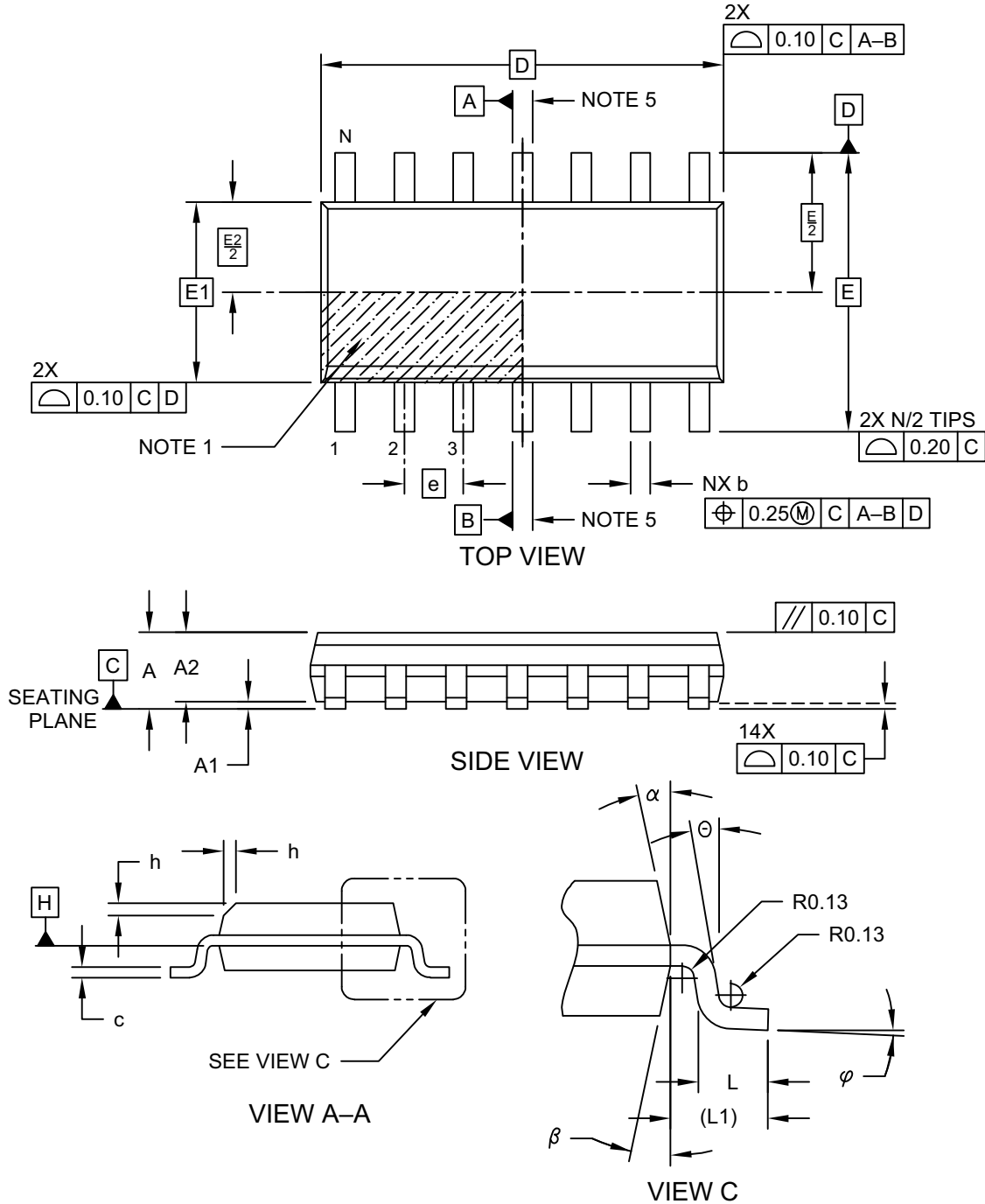

Microchip Technology Drawing No. C04-065-SL Rev D Sheet 1 of 2

MCP6486/6R/6U/7/9

14-Lead Plastic Small Outline (SL) - Narrow, 3.90 mm Body [SOIC]

Note: For the most current package drawings, please see the Microchip Packaging Specification located at <http://www.microchip.com/packaging>

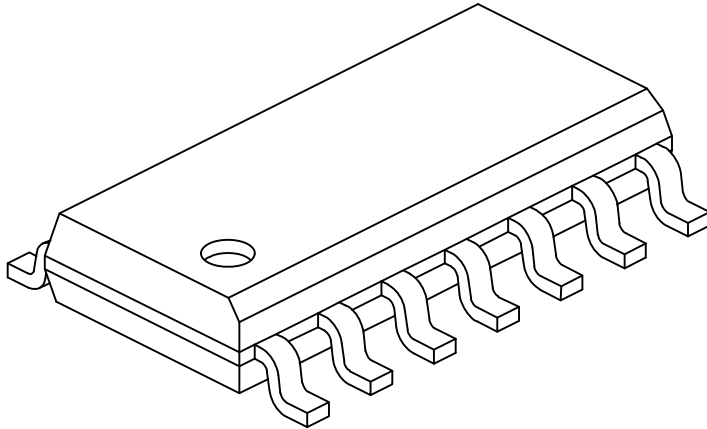

Dimension Limits	Units	MILLIMETERS		
		MIN	NOM	MAX
Number of Pins	N	14		
Pitch	e	1.27 BSC		
Overall Height	A	-	-	1.75
Molded Package Thickness	A2	1.25	-	-
Standoff §	A1	0.10	-	0.25
Overall Width	E	6.00 BSC		
Molded Package Width	E1	3.90 BSC		
Overall Length	D	8.65 BSC		
Chamfer (Optional)	h	0.25	-	0.50
Foot Length	L	0.40	-	1.27
Footprint	L1	1.04 REF		
Lead Angle	∅	0°	-	-
Foot Angle	φ	0°	-	8°
Lead Thickness	c	0.10	-	0.25
Lead Width	b	0.31	-	0.51
Mold Draft Angle Top	α	5°	-	15°
Mold Draft Angle Bottom	β	5°	-	15°

Notes:

1. Pin 1 visual index feature may vary, but must be located within the hatched area.
2. § Significant Characteristic
3. Dimension D does not include mold flash, protrusions or gate burrs, which shall not exceed 0.15 mm per end. Dimension E1 does not include interlead flash or protrusion, which shall not exceed 0.25 mm per side.
4. Dimensioning and tolerancing per ASME Y14.5M
BSC: Basic Dimension. Theoretically exact value shown without tolerances.
REF: Reference Dimension, usually without tolerance, for information purposes only.
5. Datums A & B to be determined at Datum H.

Microchip Technology Drawing No. C04-065-SL Rev D Sheet 2 of 2

14-Lead Plastic Small Outline (SL) - Narrow, 3.90 mm Body [SOIC]

Note: For the most current package drawings, please see the Microchip Packaging Specification located at <http://www.microchip.com/packaging>

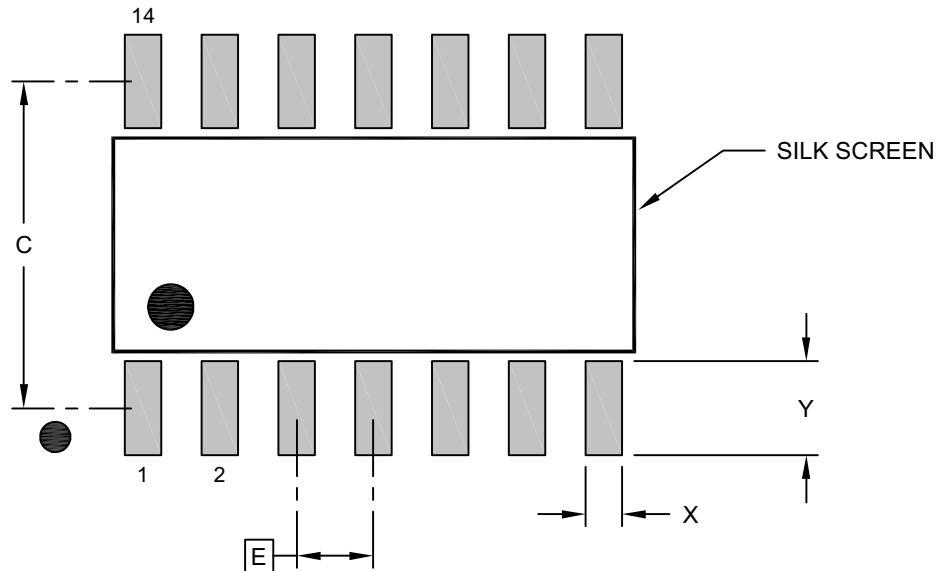

RECOMMENDED LAND PATTERN

Dimension Limits	Units	MILLIMETERS		
		MIN	NOM	MAX
Contact Pitch	E		1.27 BSC	
Contact Pad Spacing	C		5.40	
Contact Pad Width (X14)	X			0.60
Contact Pad Length (X14)	Y			1.55

Notes:

- Dimensioning and tolerancing per ASME Y14.5M
BSC: Basic Dimension. Theoretically exact value shown without tolerances.

Microchip Technology Drawing No. C04-2065-SL Rev D

MCP6486/6R/6U/7/9

14-Lead Thin Shrink Small Outline Package [ST] – 4.4 mm Body [TSSOP]

Note: For the most current package drawings, please see the Microchip Packaging Specification located at <http://www.microchip.com/packaging>

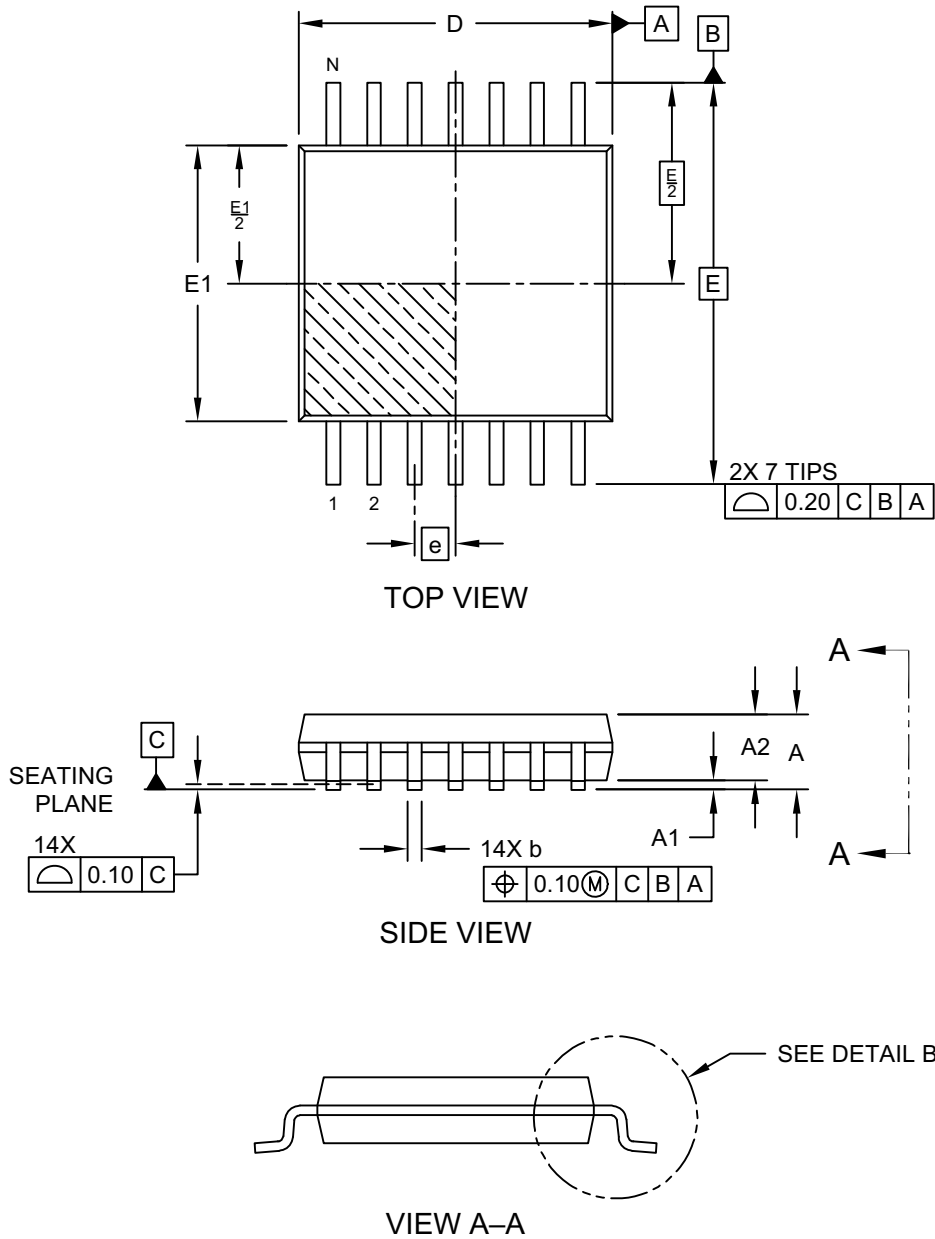

14-Lead Thin Shrink Small Outline Package [ST] – 4.4 mm Body [TSSOP]

Note: For the most current package drawings, please see the Microchip Packaging Specification located at <http://www.microchip.com/packaging>

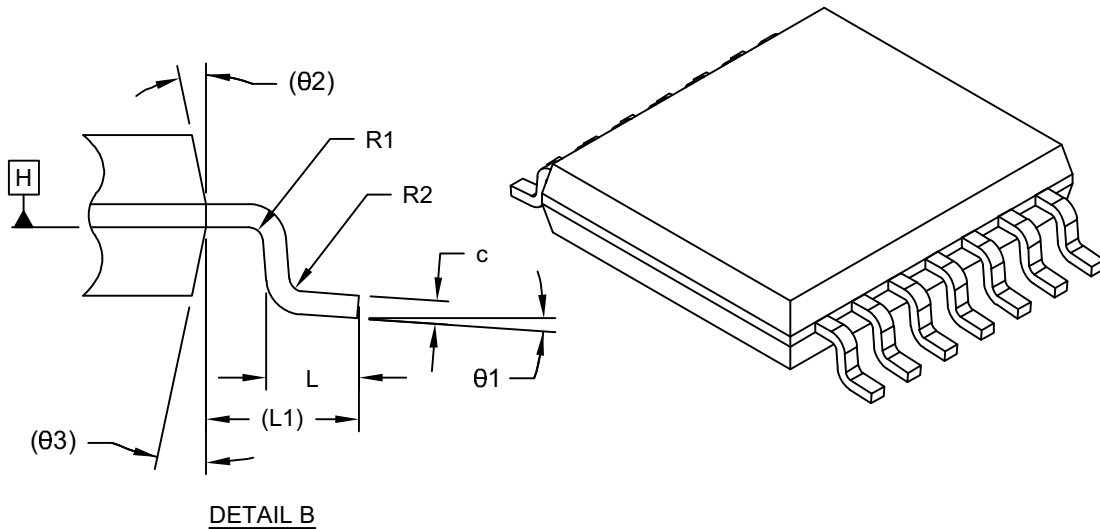

Dimension Limits	Units	MILLIMETERS		
		MIN	NOM	MAX
Number of Terminals	N	14		
Pitch	e	0.65 BSC		
Overall Height	A	–	–	1.20
Standoff	A1	0.05	–	0.15
Molded Package Thickness	A2	0.80	1.00	1.05
Overall Length	D	4.90	5.00	5.10
Overall Width	E	6.40 BSC		
Molded Package Width	E1	4.30	4.40	4.50
Terminal Width	b	0.19	–	0.30
Terminal Thickness	c	0.09	–	0.20
Terminal Length	L	0.45	0.60	0.75
Footprint	L1	1.00 REF		
Lead Bend Radius	R1	0.09	–	–
Lead Bend Radius	R2	0.09	–	–
Foot Angle	θ1	0°	–	8°
Mold Draft Angle	θ2	–	12° REF	–
Mold Draft Angle	θ3	–	12° REF	–

Notes:

- Pin 1 visual index feature may vary, but must be located within the hatched area.
- Dimensioning and tolerancing per ASME Y14.5M
 BSC: Basic Dimension. Theoretically exact value shown without tolerances.
 REF: Reference Dimension, usually without tolerance, for information purposes only.

MCP6486/6R/6U/7/9

14-Lead Thin Shrink Small Outline Package [ST] – 4.4 mm Body [TSSOP]

Note: For the most current package drawings, please see the Microchip Packaging Specification located at <http://www.microchip.com/packaging>

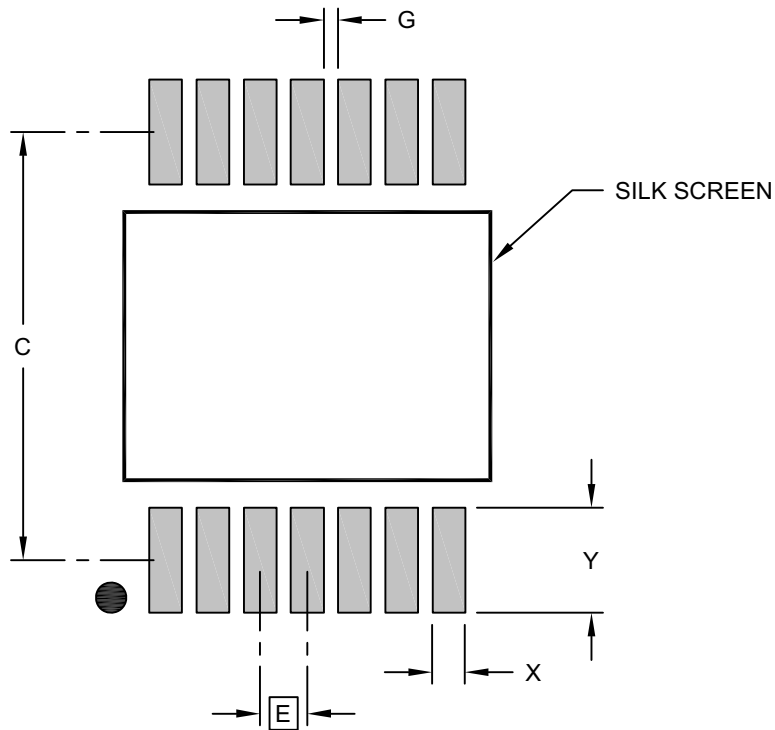

RECOMMENDED LAND PATTERN

Dimension Limits	Units	MILLIMETERS		
		MIN	NOM	MAX
Contact Pitch	E	0.65 BSC		
Contact Pad Spacing	C		5.90	
Contact Pad Width (Xnn)	X			0.45
Contact Pad Length (Xnn)	Y			1.45
Contact Pad to Contact Pad (Xnn)	G	0.20		

Notes:

1. Dimensioning and tolerancing per ASME Y14.5M
BSC: Basic Dimension. Theoretically exact value shown without tolerances.

Microchip Technology Drawing C04-2087 Rev E

5-Lead Plastic Small Outline Transistor (OT) [SOT-23]

Note: For the most current package drawings, please see the Microchip Packaging Specification located at <http://www.microchip.com/packaging>

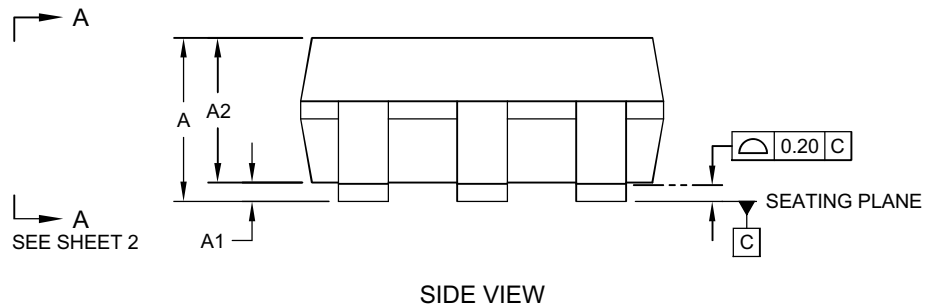
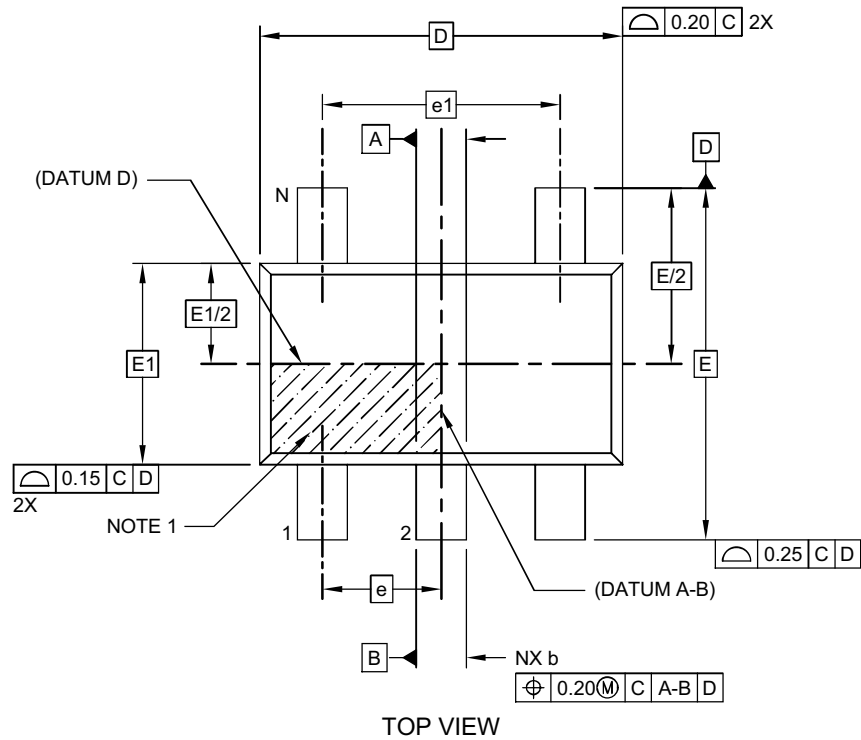

Microchip Technology Drawing C04-091-OT Rev H Sheet 1 of 2

MCP6486/6R/6U/7/9

5-Lead Plastic Small Outline Transistor (OT) [SOT-23]

Note: For the most current package drawings, please see the Microchip Packaging Specification located at <http://www.microchip.com/packaging>

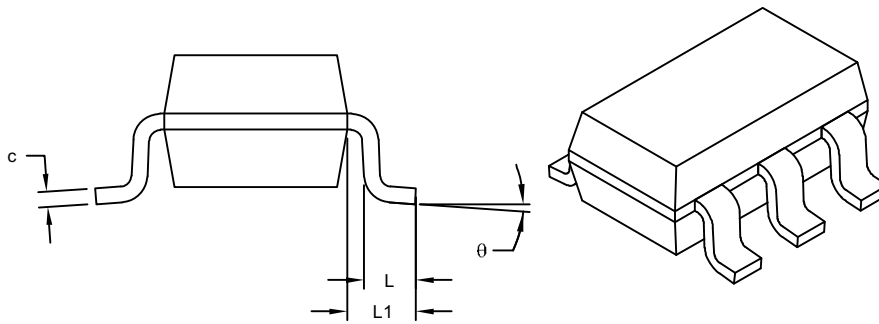

VIEW A-A
SHEET 1

Dimension Limits	Units	MILLIMETERS		
		MIN	NOM	MAX
Number of Pins	N	5		
Pitch	e	0.95 BSC		
Outside lead pitch	e1	1.90 BSC		
Overall Height	A	0.90	-	1.45
Molded Package Thickness	A2	0.89	-	1.30
Standoff	A1	-	-	0.15
Overall Width	E	2.80 BSC		
Molded Package Width	E1	1.60 BSC		
Overall Length	D	2.90 BSC		
Foot Length	L	0.30	-	0.60
Footprint	L1	0.60 REF		
Foot Angle	θ	0°	-	10°
Lead Thickness	c	0.08	-	0.26
Lead Width	b	0.20	-	0.51

Notes:

- Dimensions D and E1 do not include mold flash or protrusions. Mold flash or protrusions shall not exceed 0.25mm per side.
- Dimensioning and tolerancing per ASME Y14.5M
BSC: Basic Dimension. Theoretically exact value shown without tolerances.
REF: Reference Dimension, usually without tolerance, for information purposes only.

Microchip Technology Drawing C04-091-OT Rev H Sheet 2 of 2

5-Lead Plastic Small Outline Transistor (OT) [SOT-23]

Note: For the most current package drawings, please see the Microchip Packaging Specification located at <http://www.microchip.com/packaging>

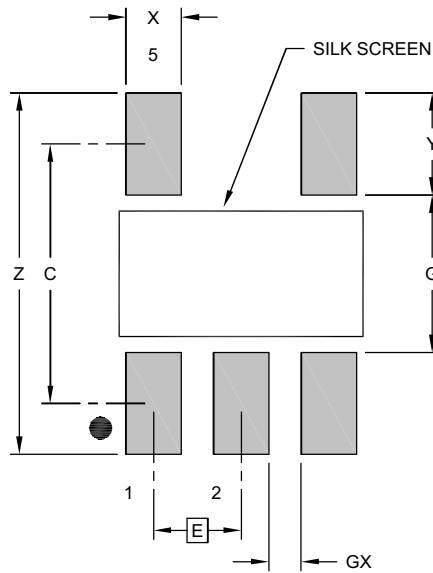

RECOMMENDED LAND PATTERN

Dimension Limits	Units	MILLIMETERS		
		MIN	NOM	MAX
Contact Pitch	E	0.95 BSC		
Contact Pad Spacing	C		2.80	
Contact Pad Width (X5)	X			0.60
Contact Pad Length (X5)	Y			1.10
Distance Between Pads	G	1.70		
Distance Between Pads	GX	0.35		
Overall Width	Z			3.90

Notes:

1. Dimensioning and tolerancing per ASME Y14.5M

BSC: Basic Dimension. Theoretically exact value shown without tolerances.

Microchip Technology Drawing No. C04-2091-OT Rev H

MCP6486/6R/6U/7/9

NOTES:

APPENDIX A: REVISION HISTORY

Revision B (March 2023)

The following is a list of modifications and corrections:

- Corrected title for [Figure 2-8](#).
- Added packaging information for MCP6489-E/ST and MCP6489T-E/ST in [Product Identification System](#).
- Added section [Product Identification System \(Automotive\)](#).

Revision A (May 2022)

- Original release of this document.

MCP6486/6R/6U/7/9

NOTES:

MCP6486/6R/6U/7/9

PRODUCT IDENTIFICATION SYSTEM (AUTOMOTIVE)

To order or obtain information, e.g., on pricing or delivery, refer to the factory or the listed sales office.

<u>PART NO.</u>	$\overset{(1)}{\times}$	$\overset{-}{\times}$	$\overset{/}{\times\! \times}$	$\overset{(2)}{\times\! \times\! \times}$	Examples:
Device	Tape and Reel Option	Temperature Range	Package	CLASS	
Device:	MCP6486	Single Op Amp			a) MCP6486T-E/LTVAO: Tape and Reel, Automotive, Extended temperature, 5LD SC-70 package
	MCP6486T	Single Op Amp (Tape and Reel) (SC-70, SOT-23)			b) MCP6486T-E/OTVAO: Tape and Reel, Automotive, Extended temperature, 5LD SOT-23 package
	MCP6486RT	Single Op Amp (Tape and Reel) (SOT-23)			c) MCP6486RT-E/OTVAO: Tape and Reel, Automotive, Extended temperature, 5LD SOT-23 package
	MCP6486UT	Single Op Amp (Tape and Reel) (SC-70, SOT-23)			d) MCP6486UT-E/LTVAO: Tape and Reel, Automotive, Extended temperature, 5LD SC-70 package
	MCP6487	Dual Op Amp			e) MCP6486UT-E/OTVAO: Tape and Reel, Automotive, Extended temperature, 5LD SOT-23 package
	MCP6487T	Dual Op Amp (Tape and Reel for SOIC, MSOP)			a) MCP6487-E/SNVAO: Automotive, Extended temperature, 8LD SOIC package
	MCP6489	Quad Op Amp			b) MCP6487-E/MSVAO: Automotive, Extended temperature, 8LD MSOP package
	MCP6489T	Quad Op Amp (Tape and Reel for TSSOP and SOIC)			c) MCP6487T-E/SNVAO: Tape and Reel, Automotive, Extended temperature, 8LD SOIC package
					d) MCP6487T-E/MSVAO: Tape and Reel, Automotive, Extended temperature, 8LD MSOP package
Temperature Range:	E = -40°C to +125°C				a) MCP6489-E/STVAO: Automotive, Extended temperature, 14LD TSSOP package
Package:	LT	= Plastic Package (SC-70), 5-lead (MCP6486 only)			b) MCP6489-E/SLVAO: Automotive, Extended temperature, 14LD SOIC package
	OT	= Plastic Small Outline transistor (SOT23), 5-Lead, (MCP6486 only)			c) MCP6489T-E/STVAO: Tape and Reel, Automotive, Extended temperature, 14LD TSSOP package
	SN	= Plastic Small Outline, (3.90 mm), 8-lead (MCP6487)			d) MCP6489T-E/SLVAO: Tape and Reel, Automotive, Extended temperature, 14LD SOIC package
	MS	= Plastic MSOP, 8-lead MCP6487 only)			
	ST	= Plastic Thin Shrink Small Outline (4.4mm), 14-Lead, (MCP6489 only)			
	SL	= Plastic Small Outline, (3.90 mm), 14-Lead (MCP6489 only)			
Class:	(Blank)=	Non-Automotive			
	VAO	= Automotive			
Note 1:	The Tape and Reel identifier only appears in the catalog part number description. This identifier is used for ordering purposes and is not printed on the device package. Check with your Microchip Sales Office for package availability with the Tape and Reel option.				
2:	Automotive parts are AEC-Q100 qualified. Grade 1.				

Note the following details of the code protection feature on Microchip products:

- Microchip products meet the specifications contained in their particular Microchip Data Sheet.
- Microchip believes that its family of products is secure when used in the intended manner, within operating specifications, and under normal conditions.
- Microchip values and aggressively protects its intellectual property rights. Attempts to breach the code protection features of Microchip product is strictly prohibited and may violate the Digital Millennium Copyright Act.
- Neither Microchip nor any other semiconductor manufacturer can guarantee the security of its code. Code protection does not mean that we are guaranteeing the product is "unbreakable" Code protection is constantly evolving. Microchip is committed to continuously improving the code protection features of our products.

This publication and the information herein may be used only with Microchip products, including to design, test, and integrate Microchip products with your application. Use of this information in any other manner violates these terms. Information regarding device applications is provided only for your convenience and may be superseded by updates. It is your responsibility to ensure that your application meets with your specifications. Contact your local Microchip sales office for additional support or, obtain additional support at <https://www.microchip.com/en-us/support/design-help/client-support-services>.

THIS INFORMATION IS PROVIDED BY MICROCHIP "AS IS". MICROCHIP MAKES NO REPRESENTATIONS OR WARRANTIES OF ANY KIND WHETHER EXPRESS OR IMPLIED, WRITTEN OR ORAL, STATUTORY OR OTHERWISE, RELATED TO THE INFORMATION INCLUDING BUT NOT LIMITED TO ANY IMPLIED WARRANTIES OF NON-INFRINGEMENT, MERCHANTABILITY, AND FITNESS FOR A PARTICULAR PURPOSE, OR WARRANTIES RELATED TO ITS CONDITION, QUALITY, OR PERFORMANCE.

IN NO EVENT WILL MICROCHIP BE LIABLE FOR ANY INDIRECT, SPECIAL, PUNITIVE, INCIDENTAL, OR CONSEQUENTIAL LOSS, DAMAGE, COST, OR EXPENSE OF ANY KIND WHATSOEVER RELATED TO THE INFORMATION OR ITS USE, HOWEVER CAUSED, EVEN IF MICROCHIP HAS BEEN ADVISED OF THE POSSIBILITY OR THE DAMAGES ARE FORESEEABLE. TO THE FULLEST EXTENT ALLOWED BY LAW, MICROCHIP'S TOTAL LIABILITY ON ALL CLAIMS IN ANY WAY RELATED TO THE INFORMATION OR ITS USE WILL NOT EXCEED THE AMOUNT OF FEES, IF ANY, THAT YOU HAVE PAID DIRECTLY TO MICROCHIP FOR THE INFORMATION.

Use of Microchip devices in life support and/or safety applications is entirely at the buyer's risk, and the buyer agrees to defend, indemnify and hold harmless Microchip from any and all damages, claims, suits, or expenses resulting from such use. No licenses are conveyed, implicitly or otherwise, under any Microchip intellectual property rights unless otherwise stated.

For information regarding Microchip's Quality Management Systems, please visit www.microchip.com/quality.

Trademarks

The Microchip name and logo, the Microchip logo, Adaptec, AVR, AVR logo, AVR Freaks, BesTime, BitCloud, CryptoMemory, CryptoRF, dsPIC, flexPWR, HELDO, IGL00, JukeBlox, KeeLoq, Klear, LANCheck, LinkMD, maXStylus, maXTouch, MediaLB, megaAVR, Microsemi, Microsemi logo, MOST, MOST logo, MPLAB, OptoLyzer, PIC, picoPower, PICSTART, PIC32 logo, PolarFire, Prochip Designer, QTouch, SAM-BA, SenGenuity, SpyNIC, SST, SST Logo, SuperFlash, Symmetricom, SyncServer, Tachyon, TimeSource, tinyAVR, UNI/O, Vectron, and XMEGA are registered trademarks of Microchip Technology Incorporated in the U.S.A. and other countries.

AgileSwitch, APT, ClockWorks, The Embedded Control Solutions Company, EtherSynch, Flashtec, Hyper Speed Control, HyperLight Load, Libero, motorBench, mTouch, Powermite 3, Precision Edge, ProASIC, ProASIC Plus, ProASIC Plus logo, Quiet-Wire, SmartFusion, SyncWorld, Temux, TimeCesium, TimeHub, TimePictra, TimeProvider, TrueTime, and ZL are registered trademarks of Microchip Technology Incorporated in the U.S.A.

Adjacent Key Suppression, AKS, Analog-for-the-Digital Age, Any Capacitor, AnyIn, AnyOut, Augmented Switching, BlueSky, BodyCom, Clockstudio, CodeGuard, CryptoAuthentication, CryptoAutomotive, CryptoCompanion, CryptoController, dsPICDEM, dsPICDEM.net, Dynamic Average Matching, DAM, ECAN, Espresso T1S, EtherGREEN, GridTime, IdealBridge, In-Circuit Serial Programming, ICSP, INICnet, Intelligent Paralleling, IntelliMOS, Inter-Chip Connectivity, JitterBlocker, Knob-on-Display, KoD, maxCrypto, maxView, memBrain, Mindi, MiWi, MPASM, MPF, MPLAB Certified logo, MPLIB, MPLINK, MultiTRAK, NetDetach, Omniscient Code Generation, PICDEM, PICDEM.net, PICkit, PICtail, PowerSmart, PureSilicon, QMatrix, REAL ICE, Ripple Blocker, RTAX, RTG4, SAM-ICE, Serial Quad I/O, simpleMAP, SimpliPHY, SmartBuffer, SmartHLS, SMART-I.S., storClad, SQI, SuperSwitcher, SuperSwitcher II, Switchtec, SynchroPHY, Total Endurance, Trusted Time, TSHARC, USBCheck, VariSense, VectorBlox, VeriPHY, ViewSpan, WiperLock, XpressConnect, and ZENA are trademarks of Microchip Technology Incorporated in the U.S.A. and other countries.

SQTP is a service mark of Microchip Technology Incorporated in the U.S.A.

The Adaptec logo, Frequency on Demand, Silicon Storage Technology, and Symmcom are registered trademarks of Microchip Technology Inc. in other countries.

GestIC is a registered trademark of Microchip Technology Germany II GmbH & Co. KG, a subsidiary of Microchip Technology Inc., in other countries.

All other trademarks mentioned herein are property of their respective companies.

© 2022-2023, Microchip Technology Incorporated and its subsidiaries.

All Rights Reserved.

ISBN: 978-1-6683-2093-8



MICROCHIP

Worldwide Sales and Service

AMERICAS

Corporate Office
2355 West Chandler Blvd.
Chandler, AZ 85224-6199
Tel: 480-792-7200
Fax: 480-792-7277
Technical Support:
<http://www.microchip.com/support>
Web Address:
www.microchip.com

Atlanta
Duluth, GA
Tel: 678-957-9614
Fax: 678-957-1455

Austin, TX
Tel: 512-257-3370

Boston
Westborough, MA
Tel: 774-760-0087
Fax: 774-760-0088

Chicago
Itasca, IL
Tel: 630-285-0071
Fax: 630-285-0075

Dallas
Addison, TX
Tel: 972-818-7423
Fax: 972-818-2924

Detroit
Novi, MI
Tel: 248-848-4000

Houston, TX
Tel: 281-894-5983

Indianapolis
Noblesville, IN
Tel: 317-773-8323
Fax: 317-773-5453
Tel: 317-536-2380

Los Angeles
Mission Viejo, CA
Tel: 949-462-9523
Fax: 949-462-9608
Tel: 951-273-7800

Raleigh, NC
Tel: 919-844-7510

New York, NY
Tel: 631-435-6000

San Jose, CA
Tel: 408-735-9110
Tel: 408-436-4270

Canada - Toronto
Tel: 905-695-1980
Fax: 905-695-2078

ASIA/PACIFIC

Australia - Sydney
Tel: 61-2-9868-6733

China - Beijing
Tel: 86-10-8569-7000

China - Chengdu
Tel: 86-28-8665-5511

China - Chongqing
Tel: 86-23-8980-9588

China - Dongguan
Tel: 86-769-8702-9880

China - Guangzhou
Tel: 86-20-8755-8029

China - Hangzhou
Tel: 86-571-8792-8115

China - Hong Kong SAR
Tel: 852-2943-5100

China - Nanjing
Tel: 86-25-8473-2460

China - Qingdao
Tel: 86-532-8502-7355

China - Shanghai
Tel: 86-21-3326-8000

China - Shenyang
Tel: 86-24-2334-2829

China - Shenzhen
Tel: 86-755-8864-2200

China - Suzhou
Tel: 86-186-6233-1526

China - Wuhan
Tel: 86-27-5980-5300

China - Xian
Tel: 86-29-8833-7252

China - Xiamen
Tel: 86-592-2388138

China - Zhuhai
Tel: 86-756-3210040

ASIA/PACIFIC

India - Bangalore
Tel: 91-80-3090-4444

India - New Delhi
Tel: 91-11-4160-8631

India - Pune
Tel: 91-20-4121-0141

Japan - Osaka
Tel: 81-6-6152-7160

Japan - Tokyo
Tel: 81-3-6880-3770

Korea - Daegu
Tel: 82-53-744-4301

Korea - Seoul
Tel: 82-2-554-7200

Malaysia - Kuala Lumpur
Tel: 60-3-7651-7906

Malaysia - Penang
Tel: 60-4-227-8870

Philippines - Manila
Tel: 63-2-634-9065

Singapore
Tel: 65-6334-8870

Taiwan - Hsin Chu
Tel: 886-3-577-8366

Taiwan - Kaohsiung
Tel: 886-7-213-7830

Taiwan - Taipei
Tel: 886-2-2508-8600

Thailand - Bangkok
Tel: 66-2-694-1351

Vietnam - Ho Chi Minh
Tel: 84-28-5448-2100

EUROPE

Austria - Wels
Tel: 43-7242-2244-39
Fax: 43-7242-2244-393

Denmark - Copenhagen
Tel: 45-4485-5910
Fax: 45-4485-2829

Finland - Espoo
Tel: 358-9-4520-820

France - Paris
Tel: 33-1-69-53-63-20
Fax: 33-1-69-30-90-79

Germany - Garching
Tel: 49-8931-9700

Germany - Haan
Tel: 49-2129-3766400

Germany - Heilbronn
Tel: 49-7131-72400

Germany - Karlsruhe
Tel: 49-721-625370

Germany - Munich
Tel: 49-89-627-144-0
Fax: 49-89-627-144-44

Germany - Rosenheim
Tel: 49-8031-354-560

Israel - Ra'anana
Tel: 972-9-744-7705

Italy - Milan
Tel: 39-0331-742611
Fax: 39-0331-466781

Italy - Padova
Tel: 39-049-7625286

Netherlands - Drunen
Tel: 31-416-690399
Fax: 31-416-690340

Norway - Trondheim
Tel: 47-7288-4388

Poland - Warsaw
Tel: 48-22-3325737

Romania - Bucharest
Tel: 40-21-407-87-50

Spain - Madrid
Tel: 34-91-708-08-90
Fax: 34-91-708-08-91

Sweden - Gothenberg
Tel: 46-31-704-60-40

Sweden - Stockholm
Tel: 46-8-5090-4654

UK - Wokingham
Tel: 44-118-921-5800
Fax: 44-118-921-5820