



Product Change Notification / SYST-20SYRM787

Date:

23-Mar-2023

Product Category:

Inductive Position Sensors

PCN Type:

Document Change

Notification Subject:

Data Sheet - LX34211 - Inductive Position Sensor with Embedded MCU

Affected CPNs:

[SYST-20SYRM787_Affected_CPN_03232023.pdf](#)

[SYST-20SYRM787_Affected_CPN_03232023.csv](#)

Notification Text:

SYST-20SYRM787

Microchip has released a new Datasheet for the LX34211 - Inductive Position Sensor with Embedded MCU of devices. If you are using one of these devices please read the document located at [LX34211 - Inductive Position Sensor with Embedded MCU](#).

Notification Status: Final

Description of Change:

The following is the list of modifications:

- Updated Electrical Characteristics

Impacts to Data Sheet: See above details.

Reason for Change: To Improve Productivity

Change Implementation Status: Complete

Date Document Changes Effective: 23 Mar 2023

NOTE: Please be advised that this is a change to the document only the product has not been changed.

Markings to Distinguish Revised from Unrevised Devices: N/A

Attachments:

[LX34211 - Inductive Position Sensor with Embedded MCU](#)

Please contact your local [Microchip sales office](#) with questions or concerns regarding this notification.

Terms and Conditions:

If you wish to receive Microchip PCNs via email please register for our PCN email service at our [PCN home page](#) select register then fill in the required fields. You will find instructions about registering for Microchips PCN email service in the [PCN FAQ](#) section.

If you wish to change your PCN profile, including opt out, please go to the [PCN home page](#) select login and sign into your myMicrochip account. Select a profile option from the left navigation bar and make the applicable selections.

Affected Catalog Part Numbers (CPN)

LX34211QPW-TR

LX34211QPW-TR-V01

LX34211QPW-TR-VAO

Inductive Position Sensor with Embedded MCU

Features

- 12-Bit Positional Output Resolution
- One 0 - 5V DAC Output of Position
- One PWM Output of Position
- Adjustable Position Sensor Gain
- High Automatic Gain Control for Larger Airgaps
- 6-Segment Calibration
- Dynamic Calibration for Extended Accuracy over Airgap
- Immune to Stray Magnetic Fields
- Low Temperature Drift
- Reverse Power Protection
- 32-bit CORTUS APS3 RISC MCU
- -40°C to +125°C Operation
- AEC-Q100 Certification
- ISO26262 ASIL B Developed and Supported

Applications

- Automotive Actuators
- Industrial Position
- Medical Control

Description

The LX34211 is a highly accurate inductive position sensor interface IC with features that simplify the sensor design for a wide range of applications. This IC has more automatic control gain and a dynamic calibration algorithm that makes it easier to design accurate sensors with larger air gap and more mechanical tolerances with less current.

The device includes an integrated oscillator circuit for driving the primary coil of an inductive sensor, along with two independent analog conversion paths for conditioning, converting, and processing of sine and cosine analog signals from the secondary coils of the sensor. The output signal is an DAC analog or PWM signal that represents the position with 12-bit measurement range resolution.

Each analog signal path includes adjustable AGC gain and digital calibration capability to match the mechanical system variation and maximize accuracy.

The automatic gain control unit has improved gain for an even wider range of target-to-sensor airgap applications. In addition, a unique dynamic calibration algorithm corrects for errors before the on board linearization stage, maintaining accuracy over a wider range of airgaps.

The calibration information can be written to the internal nonvolatile EEPROM memory during end-of-line production resulting in improved production yields by compensating for a wider range of mechanical tolerances.

The LX34211 is available in a 14-lead TSSOP package. The device is specified over a temperature range of -40°C to +125°C making it suitable for commercial, industrial, medical, and/or automotive sensor applications.

The IC was developed using the ISO26262 standard to reach ASIL B levels as an SEooC. Redundant sensor system with two ICs can be used for ASIL-C and ASIL-D applications.

LX34211

Package Types

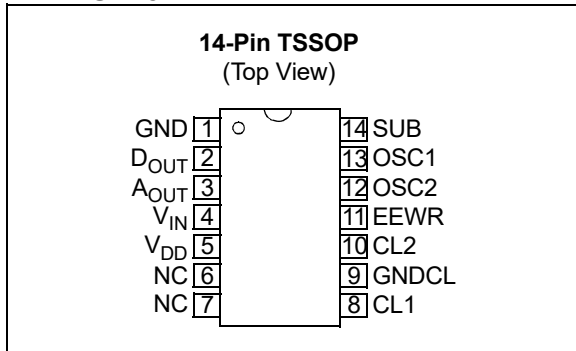

Typical Application

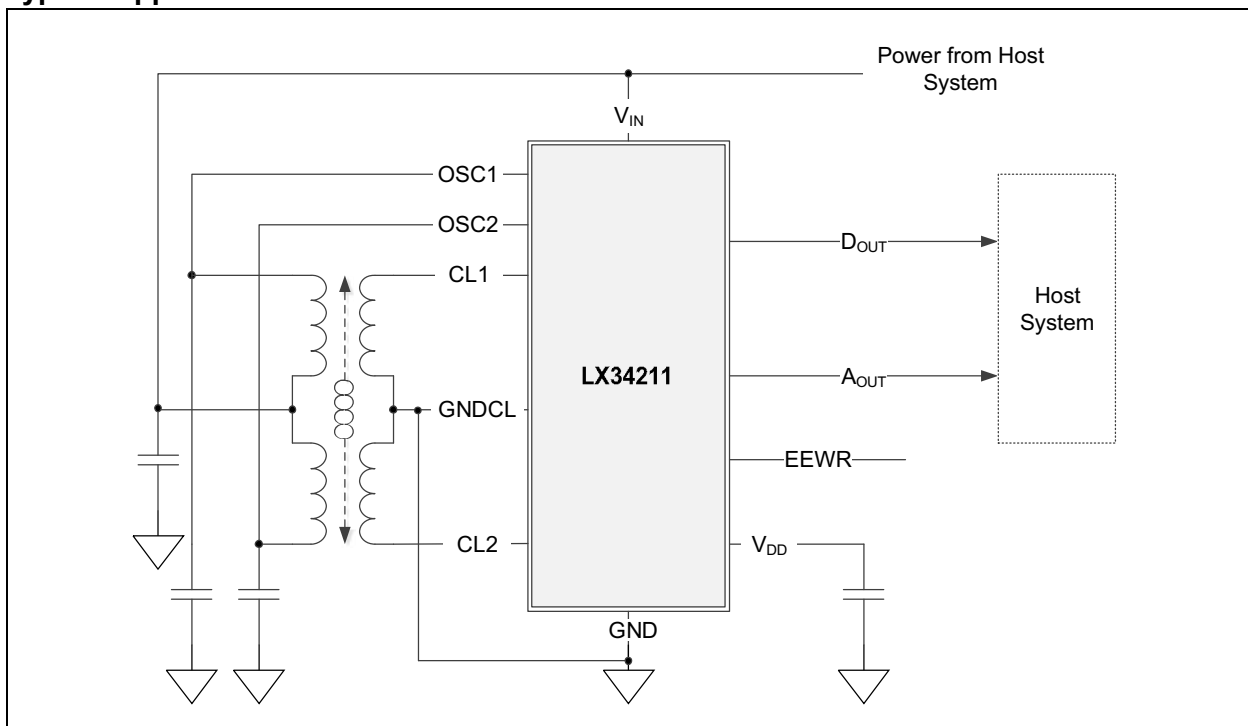

Block Diagram

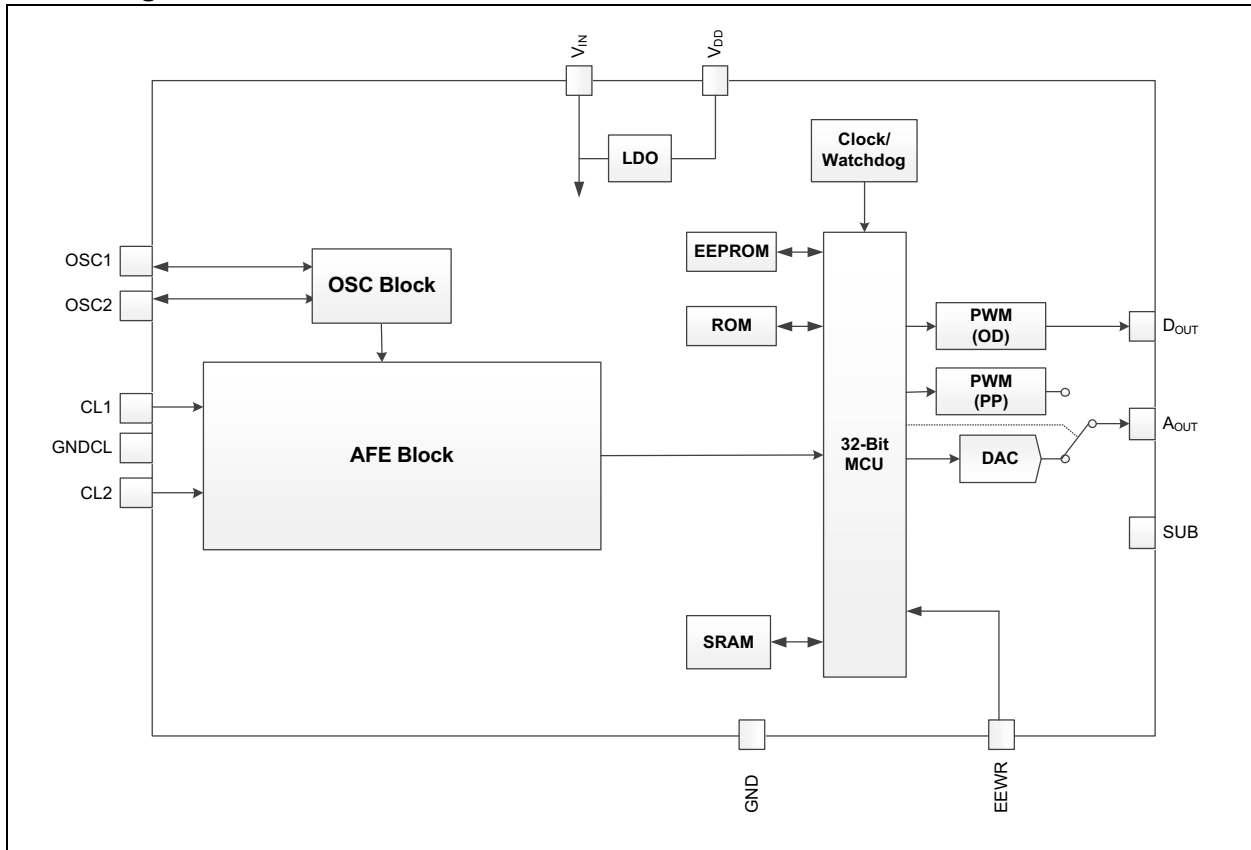

LX34211

1.0 ELECTRICAL CHARACTERISTICS

1.1 Electrical Specifications

Absolute Maximum Ratings †

Supply Input Voltage Pin (V_{IN})	-7V to 20V
Load Current on V_{DD} Pin	-1 mA to 15 mA
Voltage on OSC1 and OSC2 Pins	-0.3V to 16V
Voltage on CL1, CL2, EEWR Pins	-0.5V to 3.6V
Voltage on A_{OUT} , D_{OUT} Pins	-0.5V to 16V
Operating Humidity (non-condensing)	0% to 95%
Operating Temperature	-40°C to +125°C
Storage Temperature	-40°C to +150°C
Lead Temperature (soldering, 10 seconds)	+300°C
Package Peak Temperature for Solder Reflow (40 seconds exposure)	+260°C
ESD Rating – All Pins except Pin 11 – HBM (AEC-Q100-002D)	±2 kV
ESD Rating – Pin 11 – HBM (AEC-Q100-002D)	+2 kV/-1 kV
ESD Rating – All Pins – CDM (AEC-Q100-011)	±1.5 kV

† **Notice:** Stresses above those listed under “Absolute Maximum Ratings” may cause permanent damage to the device. This is a stress rating only and functional operation of the device at those or any other conditions above those indicated in the operation listings of this specification is not implied. Exposure above maximum rating conditions for extended periods may affect device reliability. All voltages are with respect to GND. All voltages on ESD are with respect to SUB.

Recommended Operating Range

Parameters	Symbol	Min.	Typ.	Max.	Units	Conditions
Supply Voltage	V_{IN}	4.4	5.0	5.6	V	For normal operation
V_{IN} EEPROM Program High	VIN_PH	—	—	17	V	
Supply Current	I_{IN}	—	—	9.3	mA	For normal operation, excluding oscillator tail current
Total Tank Driving Current Range	ITK	0	—	10	mA	$V_{TAP} = 5V$
Output Current	I_{AOUT0}	-15	—	-8	mA	$A_{OUT} = 0V$
	I_{AOUT5}	6	—	15	mA	$A_{OUT} = 5V$
	I_{DOUT0}	—	—	35	mA	$D_{OUT} = 0V$
Internal Clock Frequency	F_{OSC}	6.4	6.55	6.72	MHz	$T_A = \text{Room temperature}$
Operating Temperature	T_{OP}	-40	—	+125	°C	

Electrical Characteristics

Electrical Specifications: Unless otherwise indicated, the following specifications apply over the operating temperature range of $-40^{\circ}\text{C} \leq T_A \leq +125^{\circ}\text{C}$ and the following test conditions: $V_{IN} = 5\text{V}$, $V_{DD} = 3.5\text{V}$, $I_{DD} = 5\text{mA}$, $I_{I/O} = 0\text{mA}$. Typical values are at $+25^{\circ}\text{C}$.

Parameters	Symbol	Min.	Typ.	Max.	Units	Conditions
Power						
V_{IN} Input Voltage	V_{IN}	4.4	5.0	5.6	V	For normal operation
V_{IN} Supply Current	I_{IN}	—	8	9.3	mA	For normal operation, excluding oscillator tail current, $I_{DD} = 0\text{mA}$, $I_{I/O} = 0\text{mA}$, $f = 6.55\text{MHz}$
V_{IN} UV High Threshold	$V_{IN_UV_HI}$	3.8	—	4.3	V	
V_{IN} UV Low Threshold	$V_{IN_UV_LO}$	3.6	3.75	4.1	V	A_{OUT} goes low
V_{IN} OV High Threshold	$V_{IN_OV_HI}$	6.1	6.384	6.7	V	
V_{IN} OV Low Threshold	$V_{IN_OV_LO}$	6.0	6.311	6.6	V	
V_{DD} Reference Voltage						
Output Voltage	V_{DD}	3.45	3.5	3.55	V	$I_{DD} = 10\text{mA}$, trimmed
Output Current	I_{DD}	—	—	10	mA	Additional current sourced to external load(s)
V_{DD} UVLO	V_{DD_UVLO}	2.9	—	3.4	V	Rising edge
V_{DD} UVLO Hysteresis	V_{DD_UVHYST}		0.2		V	
V_{DD} Oscillation Threshold	V_{DD_RIPPLE}		0.17		V _{pk}	$1\text{MHz} < \text{Freq}(V_{DD_RIPPLE}) < 10\text{MHz}$
V_{DD} short Current	IDD_SHT_N40		120		mA	V_{DD} is shorted to GND, $V_{IN}=5.5\text{V}$, $T_A=-40^{\circ}\text{C}$
V_{DD} Short Current	IDD_SHT_25		100		mA	V_{DD} is shorted to GND, $V_{IN}=5.5\text{V}$, $T_A=25^{\circ}\text{C}$
V_{DD} Short Current	IDD_SHT_125		80		mA	V_{DD} is shorted to GND, $V_{IN}=5.5\text{V}$, $T_A=125^{\circ}\text{C}$
Oscillator						
Middle Tap Voltage	V_{TAP}	—	5	—	V	$V_{IN} = 5\text{V}$
Midtap Open Threshold	$VTAP_OPEN$	3.0	3.3	3.6	V	$V_{TAP} = 5\text{V}$
Total Tank Driving Current Range	ITK	0	—	ITK_{MAX}	mA	$V_{TAP} = 5\text{V}$
Max Total Tank Driving Current	ITK_{MAX}	9.1	12.8	—	mA	$V_{TAP} = 5\text{V}$
Swing Voltage of OSC1 and OSC2	V_{OSC}	2.2	—	10	V _{pp}	$V_{TAP} = 5\text{V}$
OSC1 Over Voltage threshold	V_{OSC_OV}		10.8		V _{pp}	$V_{TAP} = 5\text{V}$
OSC1 Under Voltage threshold	V_{OSC_UV}		2.0		V _{pp}	$V_{TAP} = 5\text{V}$
Typical Swing Voltage of OSC1	$V_{OSC1TYP}$	—	6	—	V _{pp}	$V_{TAP} = 5\text{V}$, Target at typical air gap distance. Set by external capacitor.
Reference Frequency Range	F_{OSC}	1	—	5	MHz	$V_{TAP} = 5\text{V}$
Frequency Variation	F_{OSCTOL}	-5	—	5	%	$V_{TAP} = 5\text{V}$
Reference Inductance	L_{OSC}	—	6	—	μH	$V_{TAP} = 5\text{V}$, Inductor connected to OSC1, 2 pins
Tank Circuit Quality Factor	Q_{OSC}	15	25	—	—	$V_{TAP} = 5\text{V}$
Harmonics	H_{OSC}	—	—	2	%	$V_{TAP} = 5\text{V}$, $V_{OSC1}=8.5\text{V}_{pp}$, GBNT

LX34211

Electrical Characteristics (Continued)

Electrical Specifications: Unless otherwise indicated, the following specifications apply over the operating temperature range of $-40^{\circ}\text{C} \leq T_A \leq +125^{\circ}\text{C}$ and the following test conditions: $V_{IN} = 5\text{V}$, $V_{DD} = 3.5\text{V}$, $I_{DD} = 5\text{mA}$, $I_{I/O} = 0\text{mA}$. Typical values are at $+25^{\circ}\text{C}$.						
Parameters	Symbol	Min.	Typ.	Max.	Units	Conditions
Resistance between OSC1 and V_{IN}	ROSC1_VIN	1	—	—	M Ω	$V_{IN} = 5\text{V}$, OSC1 = GND, Measure Current from OSC1 to GND
Resistance between OSC2 and V_{IN}	ROSC2_VIN	1	—	—	M Ω	$V_{IN} = 5\text{V}$, OSC2 = GND, Measure Current from OSC2 to GND
Resistance between OSC1 and GND	ROSC1_GND	1	—	—	M Ω	$V_{IN} = 0\text{V}$, OSC1 = 5V, Measure Current from OSC1 to 5V
Resistance between OSC2 and GND	ROSC2_GND	1	—	—	M Ω	$V_{IN} = 0\text{V}$, OSC2 = 5V, Measure Current from OSC2 to 5V
Resistance between OSC1 and OSC2	ROSC1&2_HI	500	—	—	k Ω	OSC1 = $1V_{pp}$, OSC2 = GND
CL1 and CL2						
CL1& CL2 Signal Regulated Amplitude @FBK=0	CLPPFBK0	30	50	65	mVpp	FBK=0
CL1& CL2 Signal regulated Amplitude @ FBK=1	CLPPFBK1	80	100	120	mVpp	FBK=1
CL1, CL2, GNDCL input open threshold	CL_OPN		1		V	
Analog-Front End						
EMI Filter Cut-off Freq	EF01		13.5		MHz	GBNT
Demodulator Gain	DAA01		14		V/V	FBK=0
Demodulator Gain	DAA02		7		V/V	FBK=1
PGA Gain Range	GRPGA	2.375	3.125	3.688	V/V	GBNT GADJ=000 to 111
PGA Gain Step	GPGAS		6		%	
13 Bits Sigma-Delta ADCs(ADC1/2) and 10bits SAR ADC(ADC3)						
ADC Resolution	RADC12	—	13	—	bits	ADC1 & ADC2
Full-Scale Range	FSR12		VDD		V	ADC1 & ADC2
Integral Nonlinearity	INL12	-1	—	1	LSB	GBNT, ADC1 & ADC2
ADC Sampling Clock	FADC12	0.1025		0.82	MHz	FCLK/8 ~ FCLK/64, ADC1&ADC2
ADC3 Resolution	RADC3		10		bits	
ADC3 Resolution	RADC3EX		12		mV	OSC1 Peak voltage per LSB
ADC3 Sampling Clock	FADC3		0.82		MHz	FCLK/8
ADC3 Integral Nonlinearity	INL3	-2		2	LSB	
CL1, CL2 Too High Threshold	CLIPPING		4040			
CL1, CL2 Too Low Threshold	LOW		1000			$(4096\text{-ADC1})^2 + (4096\text{-ADC2})^2 = \text{LOW}^2$

Electrical Characteristics (Continued)

Electrical Specifications: Unless otherwise indicated, the following specifications apply over the operating temperature range of $-40^{\circ}\text{C} \leq T_A \leq +125^{\circ}\text{C}$ and the following test conditions: $V_{IN} = 5\text{V}$, $V_{DD} = 3.5\text{V}$, $I_{DD} = 5\text{mA}$, $I_{I/O} = 0\text{mA}$. Typical values are at $+25^{\circ}\text{C}$.

Parameters	Symbol	Min.	Typ.	Max.	Units	Conditions
SINC, SINC + FIR Filter 1 and 2						
Data Update Rate	DUR00	—	1.6	—	kHz	REFRESH = 00, (SINC, SINC + FIR)
	DUR01	—	0.8	—	kHz	REFRESH = 01, (SINC, SINC + FIR)
	DUR02	—	400	—	Hz	REFRESH = 10, (SINC, SINC + FIR)
	DUR03	—	200	—	Hz	REFRESH = 11, (SINC, SINC + FIR)
Digital Filter Delay of SINC	DLSINC		256		Cycle	FADC12 Clock Cycle
Digital Filter Delay of SINC+FIR	DLSFIR		512		Cycle	FADC12 Clock Cycle
Filter SNR	FLTRSNR	—	-86	-73	dB	GBNT
Crosstalk Rejection	CTR	—	-44	—	dB	GBNT
Power Supply Rejection Ratio	PSRR	—	-86	—	dB	GNBT
Internal Clock						
Clock Frequency	FCLK	6.4	6.55	6.72	MHz	After trimming, $T_A = +25^{\circ}\text{C}$
Clock Frequency Tolerance	FCLK_TOL	-6	—	6	%	$T_A = -40^{\circ}\text{C}$ to 125°C
Processing Resources						
MCU Data Bus	MCU01	—	32	—	bits	
MCU Instruction Size	MCU02	16	—	32	bits	
ROM Size	MCU03	—	12	—	Kbytes	32-bit words
SRAM Size	MCU04	—	128	—	bytes	Application data, 32-bit words
EEPROM Write Endurance	MCU05	100	—	—	cycles	
EEPROM Size	MCU06	—	16	—	words	16-bit words
Watchdog Timer						
Power-Up Watchdog Timer	TPUWT	—	20.4	—	ms	
Start-Up Time						
Start-Up Time	TS0	—	4.5	25	ms	A_{OUT} = Analog, 2.5V, Time interval between $V_{IN} = V_{IN_UVHI}$ to A_{OUT} reaches 2.5V, Refresh = 1.6kHz, $T_A = 25^{\circ}\text{C}$, GBNT
	TS1	—	4.7	26		A_{OUT} = Analog, 2.5V, Time interval between $V_{IN} = V_{IN_UVHI}$ to A_{OUT} reaches 2.5V, Refresh = 0.8kHz, $T_A = 25^{\circ}\text{C}$, GBNT
	TS2	—	6.0	28		A_{OUT} = Analog, 2.5V, Time interval between $V_{IN} = V_{IN_UVHI}$ to A_{OUT} reaches 2.5V, Refresh = 400Hz, $T_A = 25^{\circ}\text{C}$, GBNT
	TS3	—	8.5	30		A_{OUT} = Analog, 2.5V, Time interval between $V_{IN} = V_{IN_UVHI}$ to A_{OUT} reaches 2.5V, Refresh = 200Hz, $T_A = 25^{\circ}\text{C}$, GBNT

LX34211

Electrical Characteristics (Continued)

Electrical Specifications: Unless otherwise indicated, the following specifications apply over the operating temperature range of $-40^{\circ}\text{C} \leq T_A \leq +125^{\circ}\text{C}$ and the following test conditions: $V_{IN} = 5\text{V}$, $V_{DD} = 3.5\text{V}$, $I_{DD} = 5\text{mA}$, $I_{IO} = 0\text{mA}$. Typical values are at $+25^{\circ}\text{C}$.

Parameters	Symbol	Min.	Typ.	Max.	Units	Conditions
D_{OUT} (PWM, Open-Drain)						
Frequency	D _{OUT01}	1.556	1.6	1.644	kHz	Refresh = 1.6 kHz, after trimming, $+25^{\circ}\text{C}$
Minimum PWM Duty	D _{OUT02}	—	0.3	—	%	HCLMP = 1023, LCLMP = 0, ORIGIN = 0, Frequency = 1.6 kHz
Maximum PWM Duty	D _{OUT03}	—	—	100	%	No clamped output
PWM Jitter	D _{OUT04}	—	0.2	—	%P	%P = % Period
Maximum Sink Current	D _{OUT05}	—	—	-35	mA	D _{OUT} = OD PWM
A_{OUT} (As Address Selection)						
High-Level Input Voltage	AOUT_VIH	2.0	—	—	V	
Low-Level Input Voltage	AOUT_VLO	—	—	0.3	V	
A_{OUT} (Analog Output)						
A _{OUT} Analog Range	AOUT_R	0	—	100	%V _{IN}	A _{OUT} level is dependent of V _{IN}
A _{OUT} Low Voltage	VAOUT_LO	—	—	4	%V _{IN}	R _{L_AOUT} = 10 k Ω to V _{IN}
A _{OUT} High Voltage	VAOUT_HI	96	—	—	%V _{IN}	R _{L_AOUT} = 10 k Ω to GND
A _{OUT} Output Load	RL_AOUT	7	10	—	k Ω	
A _{OUT} Sink Current	I _{AOUT0}	-8	—	15	mA	A _{OUT} = 0V
A _{OUT} Source Current	I _{AOUT5}	6	—	15	mA	A _{OUT} = 5V
A _{OUT} Slew Rate	AOUTSR1	—	0.2	—	V/ μs	C _{LOAD} = 22 nF
	AOUTSR2	—	0.1	—		C _{LOAD} = 100 nF
Ratiometric Error	V _{RatioErr}	-0.2	0	0.2	%V _{IN}	
Fault Output Low Level	VAOUT_FL10K	—	—	1	%V _{IN}	R _{L_AOUT} = 10 k Ω to V _{IN}
	VAOUT_FL1K	—	—	15		R _{L_AOUT} = 1 k Ω to V _{IN}
Fault Output High Level	VAOUT_FH10K	98	—	—	%V _{IN}	R _{L_AOUT} = 10 k Ω to GND
	VAOUT_FH1K	97	—	—		R _{L_AOUT} = 1 k Ω to GND
Ground Off Output Low Level	VAOUT_GF125C	—	—	4	%V _{IN}	Broken GND, 8 k Ω \leq R _{L_AOUT} \leq 50 k Ω to external ground, T _A \leq $+125^{\circ}\text{C}$
	VAOUT_GF105C	—	—			Broken GND, 50 k Ω < R _{L_AOUT} \leq 160 k Ω to external ground, T _A \leq $+105^{\circ}\text{C}$
	VAOUT_GF85C	—	—			Broken GND, 160 k Ω \leq R _{L_AOUT} < 600 k Ω to external ground, T _A \leq $+85^{\circ}\text{C}$.
	VAOUT_GF	—	—			Broken GND, 7 k Ω \leq R _{L_AOUT} < 8 k Ω to external ground. With 10 k Ω assist pull-up on board between V _{IN} and GND.
Ground Off Output High Level	VAOUT_GF1K	99	100	—	%V _{IN}	Broken GND, R _{L_AOUT} \geq 1 k Ω to V _{IN}
V _{IN} Open Output Low Level	VAO_VIN1K	—	0	1	%V _{IN}	Broken V _{IN} , R _{L_AOUT} \geq 1 k Ω to GND
A _{OUT} Over voltage threshold	VAOUT_OV		108			Current limit not to damage A _{OUT} internal circuit.
A_{OUT} (PWM Output)						

Electrical Characteristics (Continued)

Electrical Specifications: Unless otherwise indicated, the following specifications apply over the operating temperature range of $-40^{\circ}\text{C} \leq T_A \leq +125^{\circ}\text{C}$ and the following test conditions: $V_{IN} = 5\text{V}$, $V_{DD} = 3.5\text{V}$, $I_{DD} = 5\text{mA}$, $I_{I/O} = 0\text{mA}$. Typical values are at $+25^{\circ}\text{C}$.

Parameters	Symbol	Min.	Typ.	Max.	Units	Conditions
High-Level Output Voltage	V_{OH}	95	—	100	$\%V_{IN}$	Duty = 50%, 10 k Ω pull-down to GND
Low-Level Output Voltage	V_{OL}	0	—	200	mV	Duty = 50%, 10 k Ω pull-up to V_{IN}
Rise Time	AOUT_TR	—	10	—	μs	Duty = 50%, max $C_{LOAD} = 10\text{ nF}$
Fall Time	AOUT_TF	—	10	—	μs	Duty = 50%, max $C_{LOAD} = 10\text{ nF}$
Minimum Duty	D_{min_AOUT}	—	—	4	%	PWM (PP)
Maximum Duty	D_{max_AOUT}	94	—	—	%	PWM (PP)
Max. Drive/Sink Current	IAOUTP	-35	—	35	mA	AOUT = PWM
Output CLAMP						
Clamp High Output Level	HCLMP	0	—	99.9	$\%V_{IN}$	Pull-up Output to V_{IN}
Clamp Low Output Level	LCLMP	0	—	99.9	$\%V_{IN}$	Pull-up Output to V_{IN}
EEPROM Programming						
Programming Mode Enable Threshold	VIN_EE_ENTH	6.1	6.384	6.7		For Entering EEPROM programming mode
Program Low	VIN_PL	9.5	10	10.5	V	For EEPROM programming mode
Program Idle	VIN_PI	11.75	13	13.5	V	For EEPROM programming mode
Program High	VIN_PH	14.75	16	17	V	For EEPROM programming mode
Duration Time	td	25	—	—	μs	Duration time for each voltage state
Maximum Clock Period from Programmer	PRGCLKmax			110	μs	

Temperature Specifications⁽¹⁾

Parameters	Symbol	Min.	Typ.	Max.	Units	Conditions
Thermal Resistance, Junction to Ambient	θ_{JA}	—	+117	—	$^{\circ}\text{C/W}$	
Thermal Resistance, Junction to Case	θ_{JC}	—	+22	—	$^{\circ}\text{C/W}$	

Note 1: The θ_{JA} numbers assume no forced airflow. Junction temperature is calculated using the formula: $T_J = T_A + (P_D \times \theta_{JA})$. In particular, θ_{JA} is a function of the Printed Circuit Board (PCB) construction. The stated number above is for a four-layer board in accordance with JESD-51-7 (JEDEC®).

LX34211

2.0 PIN DESCRIPTIONS

The descriptions of the pins are listed in [Table 2-1](#).

TABLE 2-1: PIN DESCRIPTIONS

14-Lead TSSOP	Symbol	Description
1	GND	Analog and Digital Power Ground pin.
2	D _{OUT}	Digital Out pin. This pin can be programmed to open-drain PWM with current limit.
3	A _{OUT}	Analog Out pin. This pin can be programmed to provide an analog output (DAC), threshold detector, or a PWM output. PWM will be the push-pull operation. This pin can be used as an address pin for EEMODE.
4	V _{IN}	Power Supply and Internal EEPROM Programming pin. DC input power is applied to this pin for normal operation. It is also used for EEPROM programming. Bypass this pin to GND pin with a low-ESR capacitor. The recommended value is between 100 nF and 1 μF. A larger capacitance will affect the EEPROM programming.
5	V _{DD}	Regulator Output pin. This is the output of the internal voltage regulator providing power to the analog and digital blocks. Bypass this pin to GND pin with a low-ESR capacitor not lower than 0.1 μF.
6, 7	NC	Not Connected. These pins are not internally connected.
8	CL1	Sensor Signal from Secondary Coil 1 of Inductive Sensor pin.
9	GNDCL	Reference Ground for CL1 and CL2 pins. Connect CL1 and CL2 coils to GNDCL and connect the GNDCL to GND directly.
10	CL2	Sensor Signal from Secondary Coil 2 of Inductive Sensor pin.
11	EEWR	EEWR is active-low. When EEWR is low, it prohibits change to the internal EEPROM contents. The pin contains an internal pull-down so it can be left floating for normal use. If an external pull-down is desired, the SUB pin must be used as reference, and not GND. To unlock when the LOCK bits are set to '1', pull this pin to V _{DD} with 10 kΩ.
12	OSC2	Oscillator Pin 2. It connects to the second side of the primary inductor coil. An external capacitor is connected between this pin and GND as part of the LC tank circuit. The external capacitor should be low-ESR, C0G or NP0, or equivalent, rated voltage 50V.
13	OSC1	Oscillator Pin 1. It connects to the first side of the primary inductor coil. An external capacitor is connected between this pin and GND as part of the LC tank circuit. The external capacitor should be low-ESR, C0G or NP0, or equivalent, rated voltage 50V.
14	SUB	Substrate pin. It is used for ground failure protection. It should not be connected to GND. For normal applications, leave this pin open.

3.0 EEPROM CONFIGURATION

The LX34211 integrates a 16 words by 16 bits (256 bits), user-programmable EEPROM for storing calibration and configuration parameters. The calibration parameters enable the production sensor assembly to be customer-factory calibrated assuring consistent unit to unit performance.

Table 3-1 itemizes the LX34211 Configuration EEPROM contents and Table 3-2 shows the LX34211 EEPROM Configuration map. Note that EEPROM contents of ID and Reserved shall be kept as original value when EEPROM is reprogrammed.

TABLE 3-1: LX34211 EEPROM CONFIGURATION

Name	Description	Size (bits)	Words and Bits (MSb:LSb)	Sign	Min. Value	Max. Value	Default Value
ID	Customer Part ID	18	W0[15:0] W1[15:14]	No	0	3FFFF	Serial #
REFRESH	Refresh Rate	2	W1[13:12]	No	0	3	0
Reserved	Factory TRIM (Main Oscillator)	5	W1[11:7]	—	—	—	Factory Trim
Reserved	Factory TRIM (VDD)	3	W1[2:0]	—	—	—	Factory Trim
GADJ	Front-end PGA Gain	3	W1[6:4]	Yes	100b	101b	0
FBK	Radius of closed loop	1	W1[3]	No	0	1	1
CHKSUM	4-bit Checksum Value	4	W2[15:12]	No	0	—	—
S5	Slope of Sixth Segment	12	W2[11:0]	No	0	4095	511
OUTSEL	Output Setup	4	W3[15:12]	No	—	—	1011B
S0	Slope of First Segment	12	W3[11:0]	No	0	4095	511
ORIGIN	Origin	12	W4[15:12] W5[15:12] W6[15:12]	No	0	4095	0
Y5	Linearization Point 5 Y-Coordinate	12	W4[11:0]	No	0	4095	3413
X5	Linearization Point 5 X-Coordinate	12	W5[11:0]	No	0	4095	3413
Y3	Linearization Point 3 Y-Coordinate	12	W6[11:0]	No	0	4095	2047
OSCOMP	OSC Voltage Compensation	8	W7[15:12] W8[15:12]	No	0	255	255
X3	Linearization Point 3 X-Coordinate	12	W7[11:0]	No	0	4095	2047
Y1	Linearization Point 1 Y-Coordinate	12	W8[11:0]	No	0	4095	683
FILTER	Select Digital Filter	1	W9[15]	No	0	1	1
Reserved1	Reserved1	3	W9[14:12]	No	0	112	111B
X1	Linearization Point 1 X-Coordinate	12	W9[11:0]	No	0	4095	683
Reserved	Reserved	12	W10[15:10] W11[15:10]	No	0	4095	4089
LCLMP	Low Clamp	10	W10[9:0]	No	0	1023	1
HCLMP	High Clamp	10	W11[9:0]	No	0	1023	1023
Y2	Linearization Point 2 Y-Coordinate	6	W12[15:10]	Yes	-31	31	0
DSIN	Dynamic Sine Offset	10	W12[9:0]	Yes	-511	511	0
Y4	Linearization Point 4 Y-Coordinate	6	W13[15:10]	Yes	-31	31	0
SSIN	Static Sine Offset	10	W13[9:0]	Yes	-511	511	0

LX34211

TABLE 3-1: LX34211 EEPROM CONFIGURATION

Name	Description	Size (bits)	Words and Bits (MSb:LSb)	Sign	Min. Value	Max. Value	Default Value
IOSC	OSC Current Source	2	W14[15:14]	No	0	3	0
DEBUG	Debug	1	W14[13]	No	0	1	0
Reserved	Reserved	1	W14[12]	No	0	1	0
CLSEL	CL1, 2 Input Select	1	W14[11]	No	0	1	0
EELOCK	EEPROM Write Protection	1	W14[10]	No	0	1	0
DCOS	Dynamic Cosine Offset Correction	10	W14[9:0]	Yes	-511	511	0
GMTCH	Gain Match	6	W15[15:10]	Yes	-12.09%	12.09%	0
SCOS	Static Cosine Offset Correction	10	W15[9:0]	Yes	-511	511	0

TABLE 3-2: LX34211 EEPROM CONFIGURATION MAP

	MSb															LSb
	15	14	13	12	11	10	9	8	7	6	5	4	3	2	1	0
WORD0	ID[17..2]															
WORD1	ID[1..0]		REFRESH			Reserved[11..7]					GADJ[6..4]		FBK	Reserved[2..0]		
WORD2	CHKSUM[3..0]				S5[11..0]											
WORD3	OUTSEL[3..0]				S0[11..0]											
WORD4	ORIGIN[11..8]				Y5[11..0]											
WORD5	ORIGIN[7..4]				X5[11..0]											
WORD6	ORIGIN[3..0]				Y3[11..0]											
WORD7	OSCOMP[7..4]				X3[11..0]											
WORD8	OSCOMP[3..0]				Y1[11..0]											
WORD9	FILTER	RSVD1[2..0]			X1[11..0]											
WORD10	RSVD[11..6]						LCLMP[9..0]									
WORD11	RSVD[5..0]						HCLMP[9..0]									
WORD12	Y2[5..0]						DSIN[9..0]									
WORD13	Y4[5..0]						SSIN[9..0]									
WORD14	IOSC[1..0]	FMSK	RSVD	CLSEL	EELOCK	DCOS[9..0]										
WORD15	GMTCH[5..0]						SCOS[9..0]									

3.1 ID

This is the ID field. The Customer Part ID is an 18-bit field containing customer part identification information.

3.2 CHKSUM

This 4-bit value is a 4-bit cyclic redundancy check (CRC) to check the rest of content reliability through lifetime. The CRC calculation is based on the code as shown in [Example 3-1](#). Sum2 is 4-bit checksum.

3.3 Reserved

The Reserved bits contain factory trimmed information. It shall be kept the factory value when EEPROM is updated by the user.

EXAMPLE 3-1:

```

uint16_t data[16];
#define GENPOLY 0x0013U /* x^4 + x + 1 */
uint32_t makecrc4(uint32_t b)
/*
 * Takes b as input, which should be the information vector already multiplied by x^4 (ie. shifted
 * over 4 bits), and returns the crc for this input based on the defined generator polynomial GENPOLY
 */
{
    uint32_t i;
    i=1U;
    while (b>=16U) { /* >= 2^4, so degree(b) >= degree(genpoly) */
        if (((b >> (20U-i))) & 0x1U) == 1U)
        {
            b ^= GENPOLY << (16U-i); /* reduce with GENPOLY */
        }
        i++;
    }
    return b;
}
void Calculate_CRC(void)
{
    int sum2=0,sum1=0;
    for (uint8_t counter = 0U; counter <= 16U; counter++) {
        if (counter != 2U) {
            sum1 += data[counter];
        } else {
            sum1 += data[counter] & 0xFFFU;
        }
    }
    sum2 = makecrc4(((sum1 >> 16)^(sum1&0xFFFFU)) << 4);
    cout<< " IC CRC :"<<sum2<<endl<<endl;
}

```

3.4 FILTER

This bit selects the digital filter type. Setting the bit to '0' will set the filter type to SINC and setting the bit to '1' will set the filter to SINC + FIR. See [Table 3-3](#).

TABLE 3-3: FILTER CONFIGURATION

Filter Bit	Filter Type
0	SINC
1	SINC + FIR

3.5 REFRESH

This parameter sets the value of the refresh rate of the ADC update. If the PWM output is selected, the PWM frequency is always equal to the ADC update rate. See [Table 3-4](#).

TABLE 3-4: REFRESH BIT CONFIGURATION

Bit Value	Refresh Rate
0	1.6 kHz
1	0.8 kHz
2	400 Hz
3	200 Hz

3.6 IOSC

These two bits set the oscillator tail current value. See [Table 3-5](#).

TABLE 3-5: IOSC CONFIGURATION

IOSC Bits	Tail Current	Feedback
00	Full Range	Enabled
01	1/2	Enabled
10	1/4	Enabled
11	1/8	Enabled

3.7 EELOCK

There are two control signals: one is from the EEWR pin (if set to Active-Low, it disables to write EEPROM at EEMODE) and the other is for the EELOCK bits on the Configuration EEPROM (W14[10]). If the EELOCK bit is set to '1' and the EEWR pin is pulled to low, the EEPROM cannot be written. The default value of W14[10] is '0'.

3.8 OUTSEL

The OUTSEL bits provide the various output selection options. See [Table 3-6](#).

TABLE 3-6: OUTSEL BITS CONFIGURATION

Output Configuration				Remarks
Bit 1, Bit 0	A _{OUT}	Bit 3, Bit 2	D _{OUT}	
00	Reserved	00	Reserved	
01	Reserved	01	Reserved	
10	PWM (PP)	10	OD_PWM	PP = Push-Pull, OD = Open-Drain
11	Analog	11	Reserved	

3.9 SCOS

Static offset correction of the CL1 input channel used in input correction calculations.

3.10 DCOS

Dynamic offset correction of the CL1 input channel used in input correction calculations.

3.11 SSIN

Offset correction of the CL2 input channel used in input correction calculations.

3.12 DSIN

Dynamic offset correction of the CL2 input channel used in input correction calculations.

3.13 GMTCH

Value of the input channel gain mismatch correction used in input correction calculations.

3.14 OSCOMP

Maximum amplitude of the oscillator swing used in the input correction calculations. The maximum value of the OSCOMP is 255, Step 1. Multiplied by 4, it converts as internal OSCOMP data.

3.15 ORIGIN

Offset value of the system origin relative to fore-and-after position. This is not a DC output offset adjustment. Verify that the LCLMP and HCLMP parameters are not limiting the output range. Multiplied by 2, it converts as internal ORIGIN data.

3.16 HCLMP

This parameter sets the output high clamp level. The output is clamped at this value if the output swing can go above this level. The HCLMP value used in

calculations is $8 \times (\text{value} + 1) - 1$ on W11[9:0]. It reduces the maximum output swing. Maximum level is achieved with HP = 1023.

3.17 LCLMP

This parameter sets the output low clamp level. The output is clamped at this level if the output swing can go below this level. The LCLMP value raises the minimum output value from 0. The LCLMP value used in calculations is $8 \times (\text{value} - 1)$ on W10[9:0]. An output value of 0 is achieved with LCLMP = 1. The LCLMP setting value overrides the HCLMP setting if both settings are crossed over.

3.18 S0

This parameter sets the slope of the first linearization segment.

3.19 X1 and Y1

The value of the X and Y coordinates for the first linearization point. Multiplied by 2, it converts as internal data.

3.20 X3 and Y3

The value of the X and Y coordinates for the third linearization point. Multiplied by 2, it converts as internal data.

3.21 X5 and Y5

The value of the X and Y coordinates for the fifth (and last) linearization point. Multiplied by 2, it converts as internal data.

3.22 S5

This parameter sets the slope of the last linearization segment.

3.23 Y2

The value of X2 is calculated by X1 and X3 parameters as $X2 = (X1 + X3)/2$. The Y2 value is the value that can adjust the coordinates for the second linearization point. The Y2 value has polarity and the calculated value of the second coordinate (y) at X2 is $y = (Y1 + Y3)/2 + Y2$. Multiplied by 2, it converts as internal data.

3.24 Y4

The value of X4 is calculated by X3 and X5 parameters as $X4 = (X3 + X5)/2$. The Y4 value is the value that can adjust the coordinates for the fourth linearization point. The Y4 value has polarity and the calculated value of the fourth coordinate (y) at X4 is $y = (Y3 + Y5)/2 + Y4$. Multiplied by 2, it converts as internal data.

3.25 CLSEL

The CLSEL bit selects the CL1 or CL2 inputs as sine or cosine inputs. When CLSEL is set to '1', the CL1 input is selected as a sine value and the CL2 input is selected as a cosine input. When CLSEL is set to '0', the CL1 input is selected as a cosine value and the CL2 input is selected as a sine value.

3.26 GADJ

This parameter is used to adjust the gain of the Programmable Gain Amplifier (PGA). The bit, WORD1[6], is the polarity bit. The remaining two bits adjust gains. The default gain ('000b') is 3.125. Refer to [Section 4.3 "Input Amplifier and Signal Conditioning"](#) for more information.

3.27 FBK

The Bit W1[3] of the EEPROM is used to set FBK radius setting. This is user selectable. Bit value = 0 sets 50mVpp radius and Bit value =1 sets to 100mVpp radius. Factory Default setting is 1.

4.0 THEORY OF OPERATION

4.1 General Information

The LX34211 is a highly integrated programmable data conversion IC designed for interfacing to and managing of inductive sensors. The device includes an integrated oscillator circuit for driving the primary coil of an inductive sensor, along with two independent analog conversion paths for conditioning, converting, and processing of two analog signals from the secondary coils of the PCB sensor. Each path includes an EMI filter, demodulator, anti-alias filter, programmable amplifier, and a 13-bit Sigma-Delta Analog-to-Digital Converter before the signal processing unit. The signal processing unit peripherals include programmable PWM controller and a 12-bit digital-to-analog converter.

4.2 Oscillator

The on-chip excitation circuit provides a excitation current to oscillate and maintain parallel resonant circuit to generate the carrier signal for driving the primary coil of the inductive sensor via pins OSC1 and OSC2. The oscillator operates over a frequency range from 1 MHz to 5 MHz as shown in [Equation 4-1](#).

EQUATION 4-1:

$$f = \frac{1}{2\pi\sqrt{L_{eq}C_{eq}}}$$

Where:

L_{eq} = Inductance of coil between OSC1 and OSC2 pins

C_{eq} = Tanking capacitance between OSC1 and OSC2 pins.

$$C_{eq} \approx C1 * C2 / (C1 + C2)$$

The value of the inductor L_{eq} is the most critical element in the cross-coupled LC tank oscillator. Because the inductance is relatively low, the parasitic resistance of L_{eq} can dominate and impact the ability to maintain oscillation. As such, the value of the inductor L_{eq} should be as large as possible and with a high Q factor. The external capacitor should be low-ESR, C0G or NP0, or equivalent and 50V rated.

In most applications, the inductor L_{eq} is implemented as traces on a PCB. Depending on the processing of the PCB, the height and width of the trace will vary, resulting in a variation of the inductance L_{eq} and of the parasitic resistance. Because these variations will change from PCB to PCB, it is necessary to calibrate each PCB sensor independently. Care should be taken to select a PCB source which can achieve the manufacturing tolerances required by a given set of system requirements.

The amplitude of the carrier signal is a function of the primary coil tank circuit configuration and feedback of the secondary coil signals from the CL1 and CL2 inputs. The shoulder signals of the tank circuit are detected by an internal circuit. It will distort the sinusoidal waveform if the tank circuit and the secondary coil feedback signal are not within design limits.

In order to detect system Faults, the IC monitors the amplitude of the carrier signal on pin OSC1. When the amplitude is above or below the specified amplitude (see [OSCILLATOR: OSC1 Over Voltage \(\$V_{OSC_{OV}}\$ \)](#) and [OSC1 Under Voltage \(\$V_{OSC_{UV}}\$ \)](#), in the [Electrical Characteristics](#) section), the A_{OUT} output pin is forced to 0V. This output level indicates a system Fault. When initially calibrating a sensor, the voltage on OSC1 should be monitored in order to verify that the amplitude is within the specified range.

The optimal level of OSC1 is about $6V_{PP}$, with target at typical air gap distance. If the OSC1 voltage is too high, the signal levels at CL1 and CL2 may be too low. If the OSC1 voltage is too low, the signal levels at CL1 and CL2 may be too high.

Internal feedback circuit adjusts the current drive of the exciter in order to maintain the signal relationship:

EQUATION 4-2:

$$a^2 \sin^2 \theta + b^2 \cos^2 \theta = k^2$$

Where 'k' is the function of the current source amplitude controlled by the 'FBK' parameter on the EEPROM, coefficients 'a' and 'b' are the relative areas of the two secondary coils whose signals are applied to CL1 and CL2, typically two values are equal to each other by sensor design.

4.3 Input Amplifier and Signal Conditioning

Pins CL1 and CL2 are the inputs to analog front-end (AFE) block paths.

The front-end gain amplifier can be programmed with 4 bits, where the 0000b default gain value is 3.125. Bit value percentage changes can be done as shown in [Table 4-1](#).

TABLE 4-1: PROGRAMMABLE GAIN AMPLIFICATION SETTING

Bit #	Function
0	Amplification +6%
1	Amplification +12%
2	Amplification -24%

The output of the front-end gain amplifier is then passed through an anti-aliasing filter prior to input to the Sigma-Delta ADC.

4.4 Sigma-Delta ADC with Digital Filters

Each analog path includes a 4th-order 13-bit Sigma-Delta ADC with precision internal voltage reference, which produces true 12-bit measurement results. The sampling frequency for the ADC is derived from the main clock and selected by REFRESH in the configuration EEPROM. See [Table 4-2](#).

TABLE 4-2: SAMPLING FREQUENCY

REFRESH	Function
00	ADC clock = Main clock/8
01	ADC clock = Main clock/16
10	ADC clock = Main clock/32
11	ADC clock = Main clock/64

The ADC decimation filter includes a SINC filter and a half-band FIR filter. The SINC filter provides -40 dB of stop-band attenuation. Because the SINC filter does not provide the same sharp response as a finite/infinite filter response, a half-band FIR filter is also provided. The drawback of the FIR filter is that it adds delay to the input signal and this delay depends on the number of coefficients and the output data rate. The filter can be selected by the Filter setting in the configuration EEPROM.

4.5 Embedded MCU

The LX34211 includes an embedded 32-bit microcontroller core, which is used to perform filtering and math functions on the digitized samples from the ADC. The device includes a set of preprogrammed filtering and math functions, which can be selected by setting the appropriate bits in the on-chip configuration EEPROM. Also, system calibration and linearization coefficient bits are included in the on-chip configuration EEPROM.

4.6 Configuration EEPROM

The LX34211 includes a user-programmable 16 x 16 bits EEPROM for storing configuration parameters into nonvolatile memory. The device is placed into EEPROM Programming mode (EEMODE) by increasing the voltage on the V_{IN} pin to $6.5V(V_{EETH})$.

Note that the data can be clocked only after $t_2 > 4.4$ ms from last power-on, and the maximum t_2 time is less than 12 ms.

To protect the chip from accidentally entering the EE mode, the V_{IN} voltage must be above 10V continuously for at least $t_1 > 25$ μ s. The data is modulated to V_{IN} by

either increasing or decreasing the voltage. To clock a '1', V_{IN} must be increased to 16V, whereas to clock a '0', V_{IN} must be decreased to 10V. Between each data, V_{IN} must return to 13V. Each state must have a minimum duration of 20 μ s (t_2) and a maximum of 110 μ s (t_4). V_{EETH} is 9V typical. See [Figure 4-1](#).

4.6.1 LX34211 EEMODE COMMANDS

There are four commands provided for accessing the LX34211 either by writing or reading the EEPROM or ADCs for testing. Other commands are reserved. See [Table 4-3](#).

LX34211

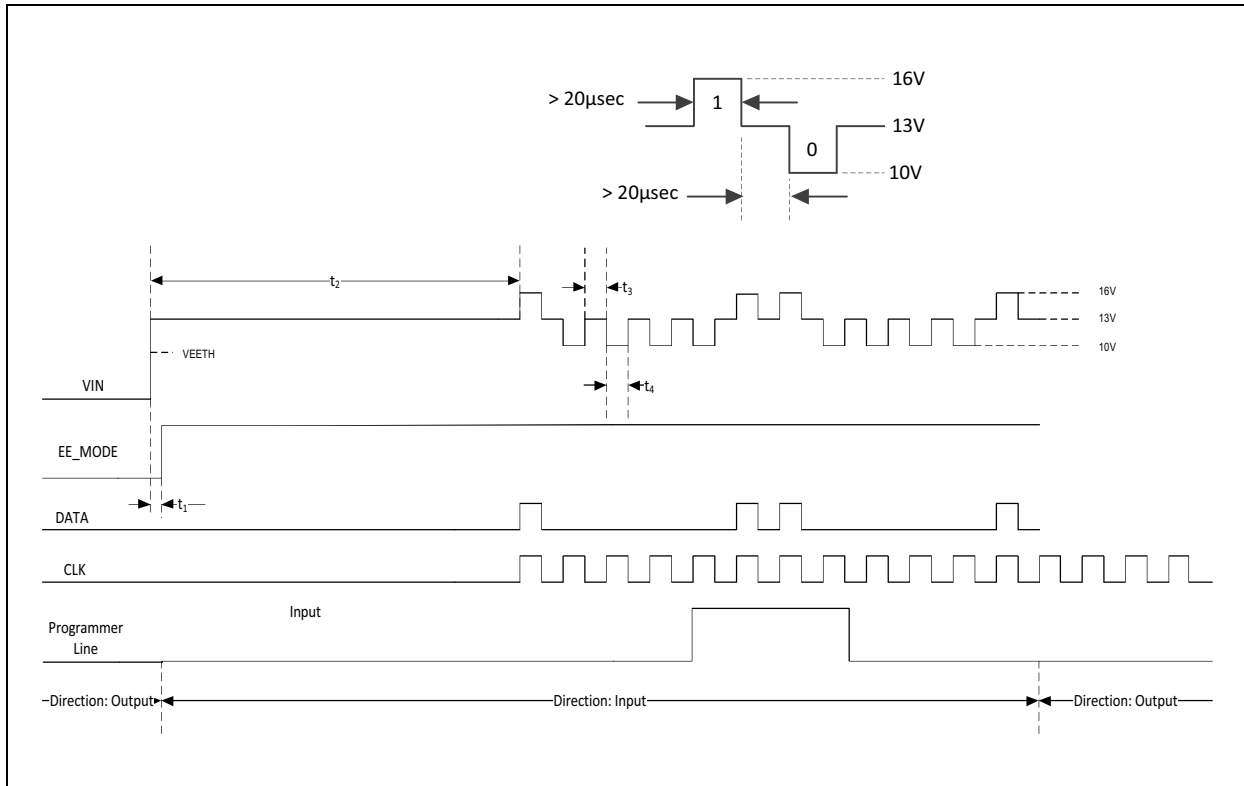

FIGURE 4-1: V_{IN} Programming Timing Diagram.

TABLE 4-3: LX4211 EEMODE COMMANDS

Bit											Command	Description	Remarks	
11	10	9	8	7	6	5	4	3	2	1				0
1	0	0	0	0	CS	CS	0	0	0	0	1	Writing mode, data A_{OUT} and (D_{OUT})	Send 12 bits command then 256 EEPROM bits and 20-bit checksum. A_{OUT} is CS input.	CS = 00 or 11
0	1	0	0	0	CS	CS	0	0	0	1	0	Writing mode, data on D_{OUT} only	Send 12 bits command then 256 EEPROM bits and 20-bit checksum. A_{OUT} is CS input.	CS = 00 or 11
1	0	1	0	0	CS	CS	0	0	1	0	1	EEPROM Read out to A_{OUT} and D_{OUT}	Send 12 bits command then 256 EEPROM bits and 20-bit checksum. A_{OUT} is CS input.	CS = 00 or 11
0	0	0	0	1	0	0	1	0	0	0	0	Read out ADCs on A_{OUT} and D_{OUT}	Send 12 bits command then Drop V_{IN} to 21 Refresh rate cycles then 36 clocks (ADC1 + ADC2 + ADC10) to read back data on A_{OUT} and D_{OUT} .	Need Unlock command
0	1	0	1	1	0	0	1	1	0	1	0	Unlock command		
Others											Reserved			

4.6.2 EEPROM WRITING WITH A_{OUT}

To enter the EEPROM Writing mode with A_{OUT}, the user must enter the EEMODE and send the 12-bit command as shown in [Example 4-1](#). Enter command 0000XX00001 then followed by 16 Words starting from LSB of the WORD0 and finishing with the MSB of the WORD15 and 20-bit checksum of the 16 Words. If the

checksum is wrong, the EEPROM will not be erased or written. The address input is A_{OUT} pin. Note that the command starts from B0, B1, B2, B3, B4, Addr, Addr, B4, B3, B2, B1, B0 and so on. [Figure 4-2](#) shows examples of EEPROM Writing with A_{OUT} and CS = 11.

EXAMPLE 4-1:

Command					Addr	Addr	Command					WORD0			WORD1			...	WORD15			Checksum		
B0	B1	B2	B3	B4			B4	B3	B2	B1	B0	B0	...	B15	B0	...	B15	...	B0	...	B15	B0	...	B19
1	0	0	0	0	0/1	0/1	0	0	0	0	1	0/1	...	0/1	0/1	...	0/1	...	0/1	...	0/1	0/1	...	0/1

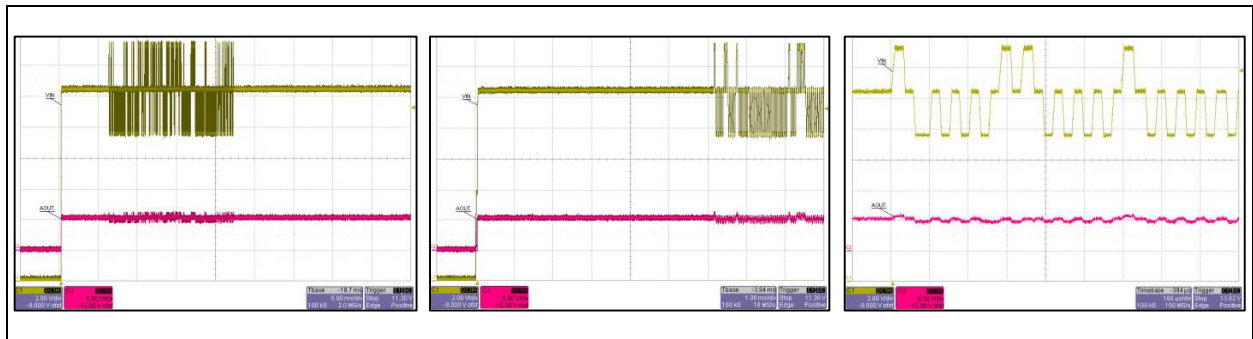

FIGURE 4-2: EEPROM Writing with A_{OUT} and CS = 11.

4.6.3 EEPROM WRITING WITH D_{OUT} ONLY

To enter the EEPROM Writing mode with D_{OUT}, the user must enter the EEMODE and send the 12-bit command as shown in [Example 4-2](#). Enter command 01000XX00010 then followed by 16 Words starting from LSB of the WORD0 and finishing with the MSB of the WORD15 and 20-bit checksum of the 16 Words. If the checksum is wrong, the EEPROM will not be erased or written. The address input is A_{OUT} pin. Note that the command starts from B0, B1, B2, B3, B4, Addr, Addr, B4, B3, B2, B1, B0 and so on. It is also required to connect A_{OUT} through 100K resistor (R4) from D_{OUT} as shown in [Figure 4-3](#).

[Figure 4-4](#) shows examples of EEPROM Writing with D_{OUT} and CS = 00.

EXAMPLE 4-2:

Command					Addr	Addr	Command					WORD0			WORD1			...	WORD15			Checksum		
B0	B1	B2	B3	B4			B4	B3	B2	B1	B0	B0	...	B15	B0	...	B15	...	B0	...	B15	B0	...	B19
0	1	0	0	0	0/1	0/1	0	0	0	1	0	0/1	...	0/1	0/1	...	0/1	...	0/1	...	0/1	0/1	...	0/1

LX34211

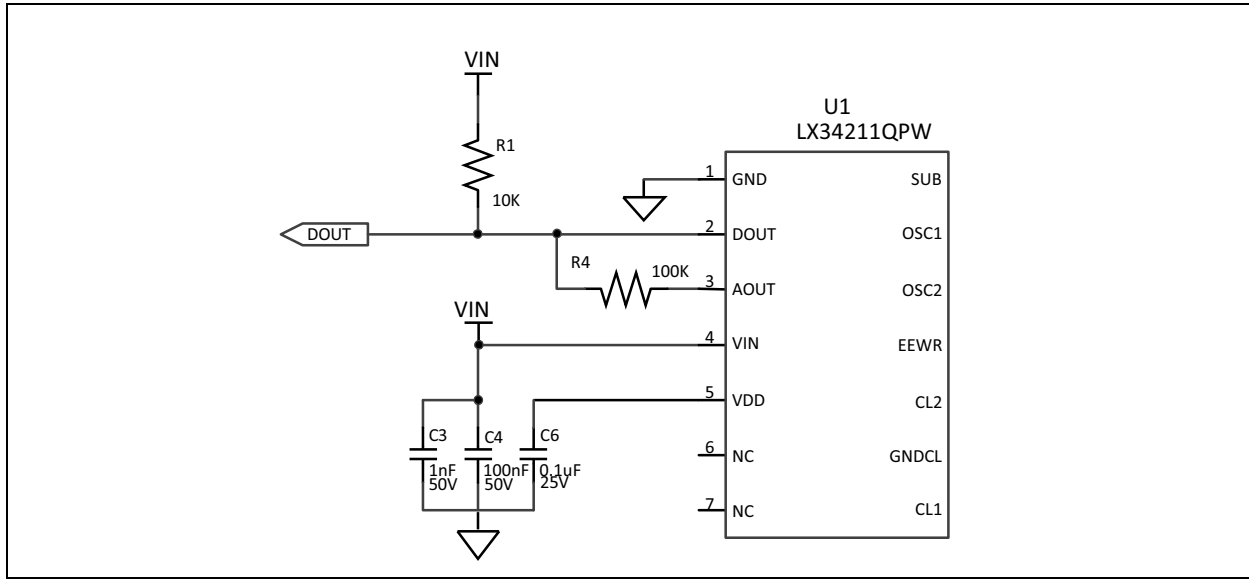

FIGURE 4-3: Connecting A_{OUT} through 100k resistor (R4) from D_{OUT} .

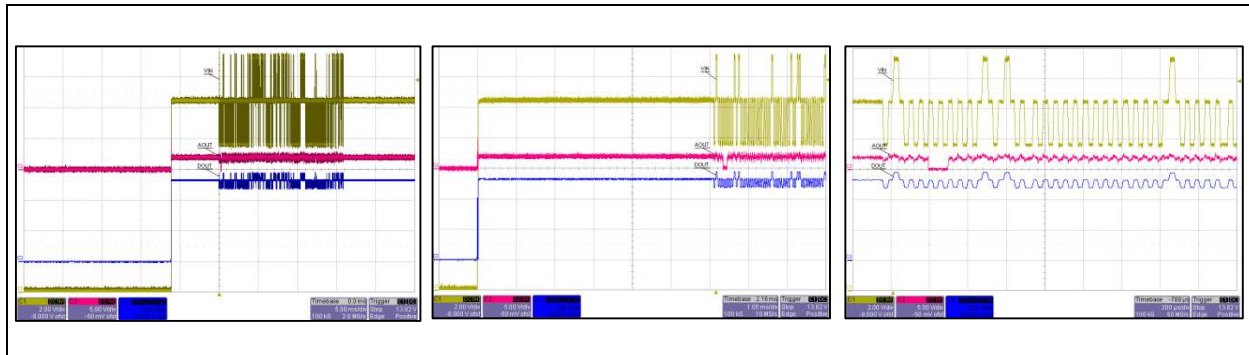

FIGURE 4-4: EEPROM Writing with D_{OUT} and $CS = 00$.

4.6.4 READING FROM EEPROM TO A_{OUT} AND D_{OUT}

To enter the EEPROM Read-Out mode from A_{OUT} , the user must enter the EEMODE and send the 12-bit command (10100XX00101) as shown in Example 4-3.

EXAMPLE 4-3:

Command					Addr	Addr	Command					WORD0	WORD1	...	WORD15	Checksum					
B0	B1	B2	B3	B4			B4	B3	B2	B1	B0	B0	...	B15	B0	...	B15	...	B0	...	B19
1	0	1	0	0	0/1	0/1	0	0	1	0	1	0/1	...	0/1	0/1	...	0/1	...	0/1	...	0/1

Once these 12-bit command have been sent, the outputs are reactivated and the A_{OUT} and D_{OUT} pins will have transitioned to logic high. To serial out the data, a clock pulse must be sent to V_{IN} . After each clock, the next bit is sent to the output, starting with bit 0 of WORD0 to bit 15 of WORD15. After bit 15 of WORD15 has been read, it will send the 20-bit checksum of WORD0 to WORD15 of EEPROM. An

extra clock at the end will output logic low. Figure 4-5 shows examples of EEPROM Reading using address = A_{OUT} and $CS = 11$.

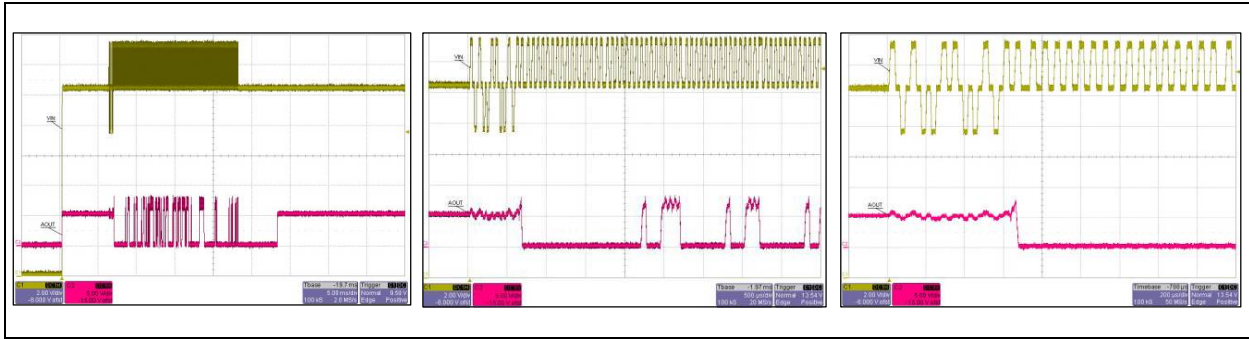

FIGURE 4-5: EEPROM Reading using Address A_{OUT} and $CS = 11$.

4.6.5 ADC READ MODE

The ADC Read mode can be used for the input calibration. When the device enters this mode, then it can read out the value of the 3 ADCs (ADC1, ADC2 and ADC10). To enter this mode, the user must enter the EEMODE and send the Unlock command and then the 12-bit command as shown in [Example 4-4](#) in order to have ADC values sent to the A_{OUT} and D_{OUT} . Then V_{IN} has to be lowered to the operating voltage. The device waits 21 refresh cycles and then it reads the ADCs. To read out the values, the V_{IN} has to be set to 13V and logic high will appear on the D_{OUT} . Then 36 clocks (ADC1 (13clocks) + ADC2 (13clocks) + ADC10 (10 clocks)) to read back data on A_{OUT} and D_{OUT} . An extra clock is needed to exit this mode. During this test mode, the refresh rate, the IOSC bits and the Filter selection are not changed.

EXAMPLE 4-4:

Unlock Command								ADC Read Command															
Command					Addr	Addr	Command					Command					Addr	Addr	Command				
B0	B1	B2	B3	B4			B4	B3	B2	B1	B0	B0	B1	B2	B3	B4			B4	B3	B2	B1	B0
0	1	0	1	1	0	0	1	1	0	1	0	0	0	0	0	1	0	0	1	0	0	0	0

Note that if selecting A_{OUT} pin read out, the user must release the pin (which is used for addressing) as soon as A_{OUT} is de-tristate. Also note that the output of the digital will go straight to the A_{OUT} output buffer. This buffer will be working with its input stage in saturation mode and with a gain of 2.5.

The consequence is that the logic high will clamp around 6.5V. The end user should therefore set this to logic high. The maximum threshold is around 5V. [Figure 4-6](#) shows examples of ADC read operation.

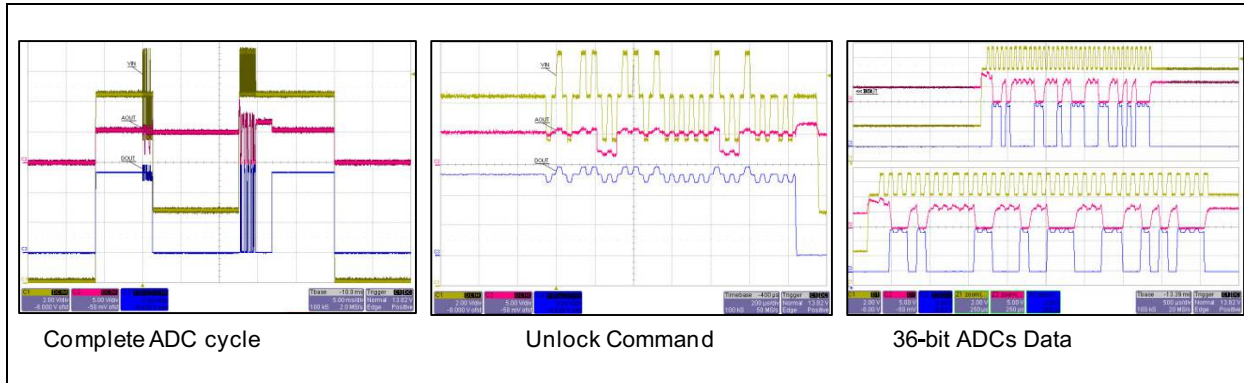

FIGURE 4-6: ADC Read Operation.

4.7 PWM Controller

A 16-bit digital PWM controller is implemented on the chip. It can generate a pulse-width modulated signal of varying period and duty cycle. The PWM module has a 2-bit pre-scalar to divide the main clock (FCLK) signal. The PWM frequency is selected by REFRESH on the configuration EEPROM. The PWM mode can be set by OUTSEL. When the D_{OUT} PWM is selected, the pull up resistor between D_{OUT} and V_{IN} or V_{DD} is needed (10 kΩ recommended). PWM frequency is trimmed at the factory.

4.8 A_{OUT}

A_{OUT} has three functions that can be programmed to provide an analog output (amplified from the DAC output), or a PWM output. PWM will be a push-pull operation. It is also used as an address pin for EEMODE. For analog output, a 12-bit DAC is implemented on the chip. The internal DAC Reference voltage is buffered of 0.4* V_{IN}. DAC output voltage is proportion to the A_{OUT}. The A_{OUT} is amplified from the DAC output and its supply voltage is from V_{IN}. Therefore, the A_{OUT} output range is limited by the V_{IN} voltage.

The start-up time (the time between the first valid A_{OUT} of the sensor from V_{IN} reaches the V_{IN} UVLO high threshold) is 4.5 ms (typical), with REFRESH = 1.6 kHz.

4.9 Protection

Versatile system diagnostic and protection functions are incorporated in the LX34211 to provide reliable protection of the device and the system. Key Fault conditions and output status are shown in [Table 4-4](#).

CL inputs are converted to digital value and firmware is monitoring the digital values with two thresholds specified on EC table as CL1, CL2 too low or high fault.

Two CL1, CL2 signals are converted to 'a' and 'b' in 12-bits range are monitored by firmware using the registers TrackLow for too-low fault and TrackClip for

too-high fault. If (|a| or |b|) > Clipping or (a²+b²)<LOW² (out of range), then related register bit0 is set to 1 and it the measured angle value is replaced from 'previous' register (hereafter PREG). In next refresh cycle, if the result is out of range, then related register bit0 value is shifted bit1 and bit0 value is set to 1 and measured angle is replaced from PREG, otherwise bit0 is set to 0 and measured angle is stored into PREG and it outputs to output pins.

When either TrackClip = 7 or TrackLow = 7 or TrackClip + TrackLow = 7, then it declares as fault and outputs are forced to low.

4.10 Reverse Power and Ground Off Protection

The LX34211 implements the reverse power protection feature when V_{IN} and GND connections are reversed. When the power connection is reversed, the internal circuits are disconnected from the supply and the outputs are pulled to ground. The LX34211 implements the ground off protection feature when the ground is disconnected.

4.11 High-Voltage LDO

A high-voltage, low-temperature drift, low-dropout, precision voltage regulator is implemented on the chip. The regulator provides the internal power to the chip and also provides power for the external components, such as pull-up resistors. Decoupling caps are required to ensure high-performance analog measurements where the recommended value is 0.1 μF. V_{DD} is pretrimmed at factory.

TABLE 4-4: FAULT CONDITIONS AND OUTPUT STATUS

Fault Condition	Output Status	Remarks
V _{IN} undervoltage	Tri-state	UVLO
V _{DD} undervoltage	Forced low	UVLO
V _{DD} unstable or oscillating	Forced low	V _{DD} noise or improper decoupling
CL1, CL2, GNDCL disconnected	Forced low	
CL1, CL2 signal too high	Forced low	Reacquire input values at next refresh cycle
CL1, CL2 signal too low	Forced low	Reacquire input values at next refresh cycle
OSC1 connection fail	Forced low	
OSC1 overvoltage	Forced low	
OSC1 undervoltage	Forced low	
ROM or RAM test failure at start-up	Forced low	Restart by μ P
EEPROM reading error or RAM writing failure	Forced low	Restart by μ P
Periodic ROM checksum failure	Forced low	Restart by μ P
Software does not follow the intended execution flow	Forced low	Restart by μ P
CPU test vector failure	Forced low	Restart by μ P

LX34211

5.0 REFERENCE SCHEMATIC

The LX34211 14-pin reference schematic is shown in Figure 5-1.

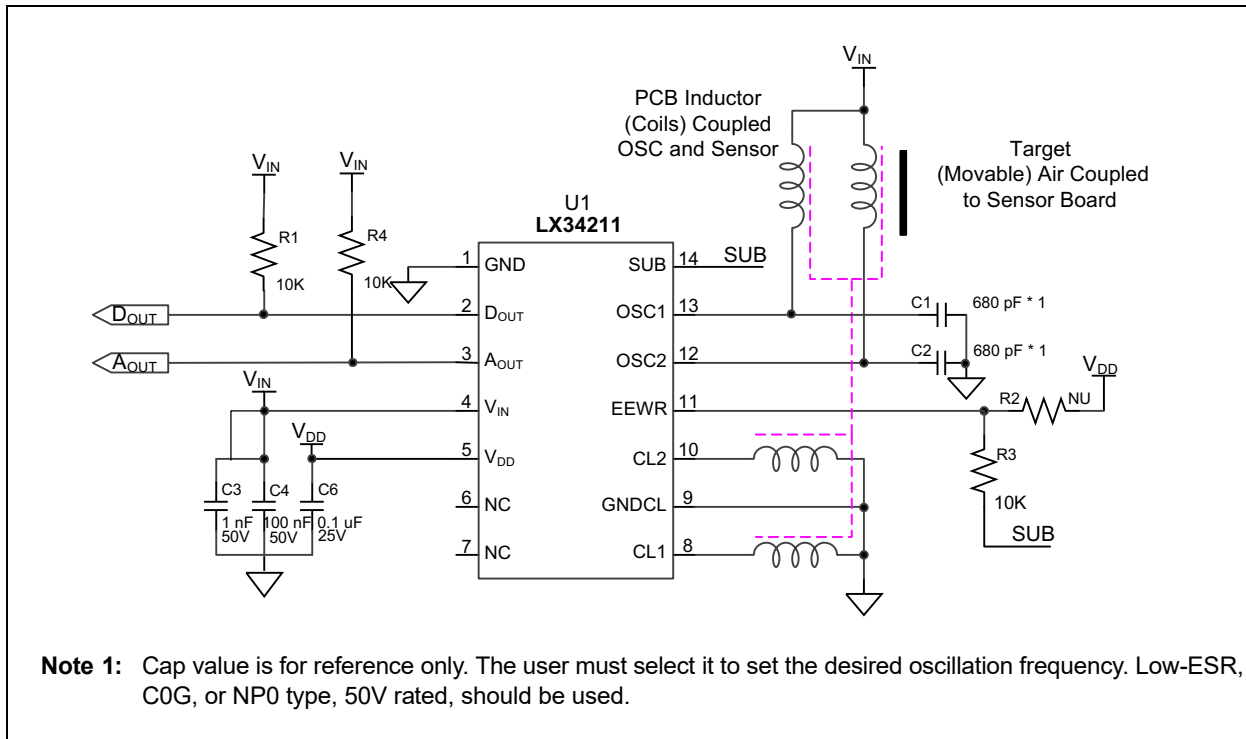
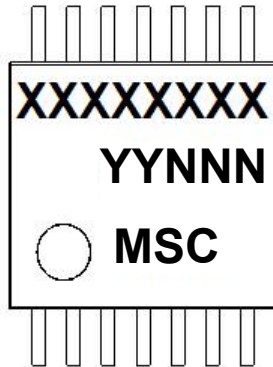

FIGURE 5-1: LX34211 14-Pin Reference Schematic.

6.0 PACKAGING INFORMATION

6.1 Package Marking Information

14-Lead TSSOP



Example

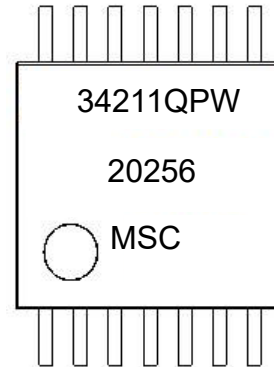

Legend:	XX...X	Device-specific information
	Y	Year code (last digit of calendar year)
	YY	Year code (last 2 digits of calendar year)
	NNN	Alphanumeric traceability code
	*	This package is Pb-free. The Pb-free JEDEC designator (e3) can be found on the outer packaging for this package.

Note: In the event the full Microchip part number cannot be marked on one line, it will be carried over to the next line, thus limiting the number of available characters for customer-specific information.

LX34211

14-Lead Thin Shrink Small Outline Package [ST] – 4.4 mm Body [TSSOP]

Note: For the most current package drawings, please see the Microchip Packaging Specification located at <http://www.microchip.com/packaging>

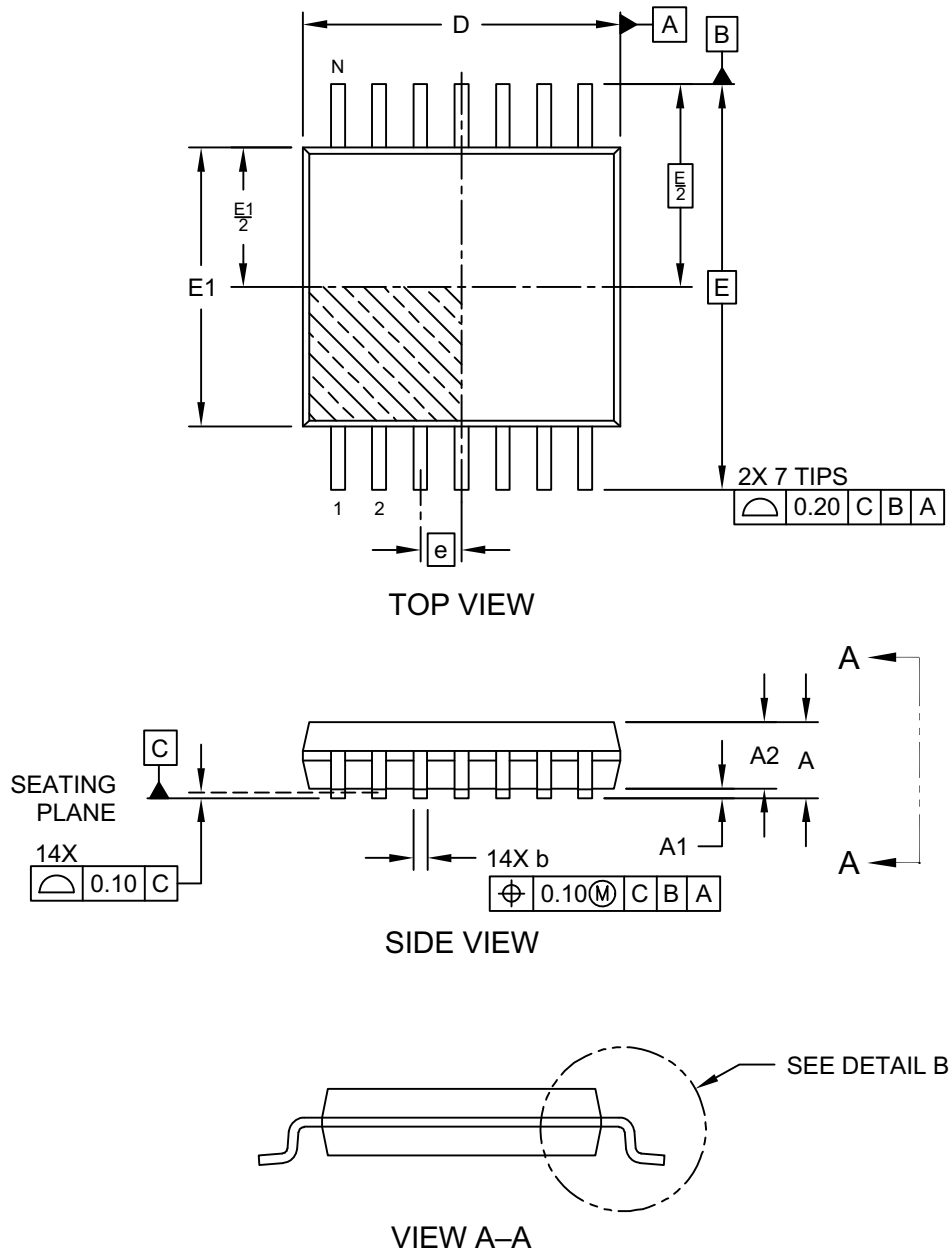

Microchip Technology Drawing C04-087 Rev E Sheet 1 of 2

14-Lead Thin Shrink Small Outline Package [ST] – 4.4 mm Body [TSSOP]

Note: For the most current package drawings, please see the Microchip Packaging Specification located at <http://www.microchip.com/packaging>

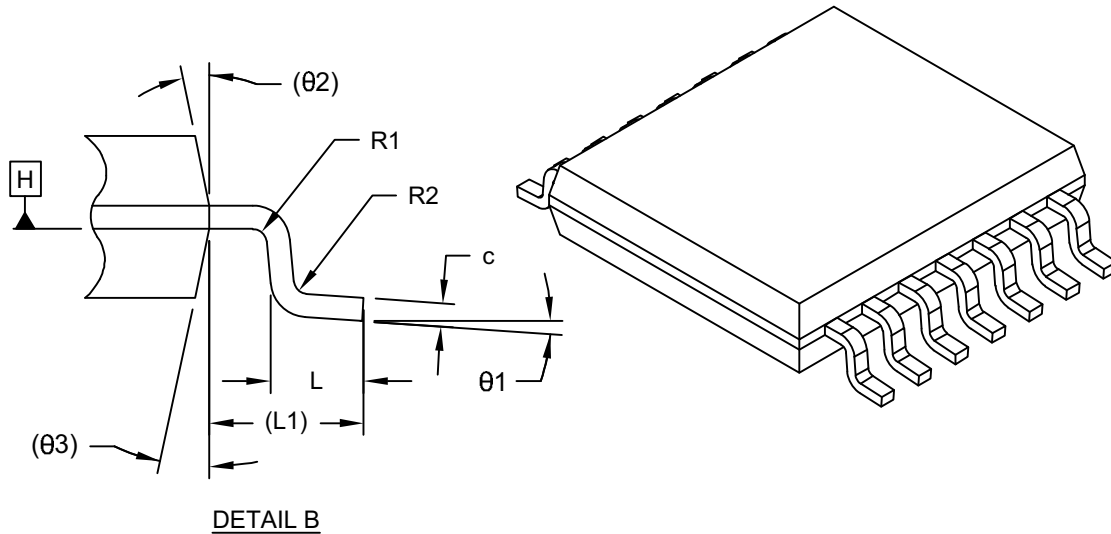

Dimension Limits	Units	MILLIMETERS		
		MIN	NOM	MAX
Number of Terminals	N	14		
Pitch	e	0.65 BSC		
Overall Height	A	–	–	1.20
Standoff	A1	0.05	–	0.15
Molded Package Thickness	A2	0.80	1.00	1.05
Overall Length	D	4.90	5.00	5.10
Overall Width	E	6.40 BSC		
Molded Package Width	E1	4.30	4.40	4.50
Terminal Width	b	0.19	–	0.30
Terminal Thickness	c	0.09	–	0.20
Terminal Length	L	0.45	0.60	0.75
Footprint	L1	1.00 REF		
Lead Bend Radius	R1	0.09	–	–
Lead Bend Radius	R2	0.09	–	–
Foot Angle	θ1	0°	–	8°
Mold Draft Angle	θ2	–	12° REF	–
Mold Draft Angle	θ3	–	12° REF	–

Notes:

- Pin 1 visual index feature may vary, but must be located within the hatched area.
- Dimensioning and tolerancing per ASME Y14.5M
 BSC: Basic Dimension. Theoretically exact value shown without tolerances.
 REF: Reference Dimension, usually without tolerance, for information purposes only.

LX34211

14-Lead Thin Shrink Small Outline Package [ST] – 4.4 mm Body [TSSOP]

Note: For the most current package drawings, please see the Microchip Packaging Specification located at <http://www.microchip.com/packaging>

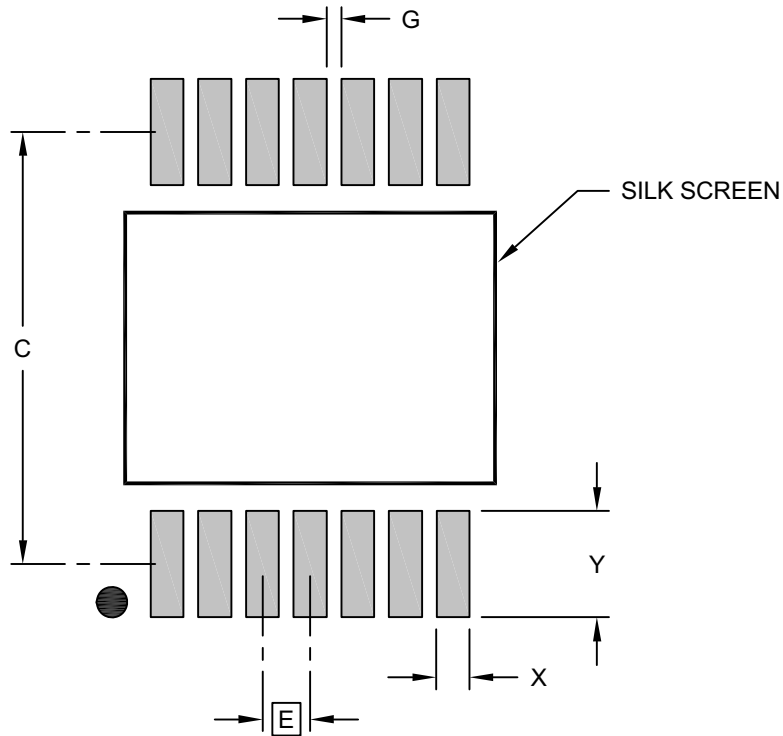

RECOMMENDED LAND PATTERN

Dimension Limits	Units	MILLIMETERS		
		MIN	NOM	MAX
Contact Pitch	E	0.65 BSC		
Contact Pad Spacing	C		5.90	
Contact Pad Width (Xnn)	X			0.45
Contact Pad Length (Xnn)	Y			1.45
Contact Pad to Contact Pad (Xnn)	G	0.20		

Notes:

1. Dimensioning and tolerancing per ASME Y14.5M

BSC: Basic Dimension. Theoretically exact value shown without tolerances.

Microchip Technology Drawing C04-2087 Rev E

APPENDIX A: REVISION HISTORY

Revision B (July 2022)

The following is the list of modifications:

- Updated [Electrical Characteristics](#).

Revision A (February 2022)

- Initial release of this document.

PRODUCT IDENTIFICATION SYSTEM

To order or obtain information, e.g., on pricing or delivery, refer to the factory or the listed sales office.

PART NO. Device	-	XX⁽¹⁾ Tape and Reel Option
Device: LX34211QPW: Inductive Position Sensor with Embedded MCU		
Tape and Reel: Blank = Standard Packaging (Tube) TR = Tape and Reel		
Examples: a) LX34211QPW: -40°C to +125°C Ambient Temperature, RoHS2 Compliant, Pb-free, 14-Lead TSSOP package a)LX34211QPW-TR: -40°C to +125°C Ambient Temperature, RoHS2 Compliant, Pb-free, 14-Lead TSSOP package, Tape and Reel		
Note 1: Tape and Reel identifier only appears in the catalog part number description. This identifier is used for ordering purposes and is not printed on the device package. Check with Microchip for package availability with the Tape and Reel option.		

Note the following details of the code protection feature on Microchip products:

- Microchip products meet the specifications contained in their particular Microchip Data Sheet.
- Microchip believes that its family of products is secure when used in the intended manner, within operating specifications, and under normal conditions.
- Microchip values and aggressively protects its intellectual property rights. Attempts to breach the code protection features of Microchip product is strictly prohibited and may violate the Digital Millennium Copyright Act.
- Neither Microchip nor any other semiconductor manufacturer can guarantee the security of its code. Code protection does not mean that we are guaranteeing the product is "unbreakable" Code protection is constantly evolving. Microchip is committed to continuously improving the code protection features of our products.

This publication and the information herein may be used only with Microchip products, including to design, test, and integrate Microchip products with your application. Use of this information in any other manner violates these terms. Information regarding device applications is provided only for your convenience and may be superseded by updates. It is your responsibility to ensure that your application meets with your specifications. Contact your local Microchip sales office for additional support or, obtain additional support at <https://www.microchip.com/en-us/support/design-help/client-support-services>.

THIS INFORMATION IS PROVIDED BY MICROCHIP "AS IS". MICROCHIP MAKES NO REPRESENTATIONS OR WARRANTIES OF ANY KIND WHETHER EXPRESS OR IMPLIED, WRITTEN OR ORAL, STATUTORY OR OTHERWISE, RELATED TO THE INFORMATION INCLUDING BUT NOT LIMITED TO ANY IMPLIED WARRANTIES OF NON-INFRINGEMENT, MERCHANTABILITY, AND FITNESS FOR A PARTICULAR PURPOSE, OR WARRANTIES RELATED TO ITS CONDITION, QUALITY, OR PERFORMANCE.

IN NO EVENT WILL MICROCHIP BE LIABLE FOR ANY INDIRECT, SPECIAL, PUNITIVE, INCIDENTAL, OR CONSEQUENTIAL LOSS, DAMAGE, COST, OR EXPENSE OF ANY KIND WHATSOEVER RELATED TO THE INFORMATION OR ITS USE, HOWEVER CAUSED, EVEN IF MICROCHIP HAS BEEN ADVISED OF THE POSSIBILITY OR THE DAMAGES ARE FORESEEABLE. TO THE FULLEST EXTENT ALLOWED BY LAW, MICROCHIP'S TOTAL LIABILITY ON ALL CLAIMS IN ANY WAY RELATED TO THE INFORMATION OR ITS USE WILL NOT EXCEED THE AMOUNT OF FEES, IF ANY, THAT YOU HAVE PAID DIRECTLY TO MICROCHIP FOR THE INFORMATION.

Use of Microchip devices in life support and/or safety applications is entirely at the buyer's risk, and the buyer agrees to defend, indemnify and hold harmless Microchip from any and all damages, claims, suits, or expenses resulting from any such use. No licenses are conveyed, implicitly or otherwise, under any Microchip intellectual property rights unless otherwise stated.

For information regarding Microchip's Quality Management Systems, please visit www.microchip.com/quality.

Trademarks

The Microchip name and logo, the Microchip logo, Adaptec, AVR, AVR logo, AVR Freaks, BesTime, BitCloud, CryptoMemory, CryptoRF, dsPIC, flexPWR, HELDO, IGL00, JukeBlox, KeeLoq, Klear, LANCheck, LinkMD, maXStylus, maXTouch, MediaLB, megaAVR, Microsemi, Microsemi logo, MOST, MOST logo, MPLAB, OptoLyzer, PIC, picoPower, PICSTART, PIC32 logo, PolarFire, Prochip Designer, QTouch, SAM-BA, SenGenuity, SpyNIC, SST, SST Logo, SuperFlash, Symmetricom, SyncServer, Tachyon, TimeSource, tinyAVR, UNI/O, Vectron, and XMEGA are registered trademarks of Microchip Technology Incorporated in the U.S.A. and other countries.

AgileSwitch, APT, ClockWorks, The Embedded Control Solutions Company, EtherSynch, Flashtec, Hyper Speed Control, HyperLight Load, Libero, motorBench, mTouch, Powermite 3, Precision Edge, ProASIC, ProASIC Plus, ProASIC Plus logo, Quiet-Wire, SmartFusion, SyncWorld, Temux, TimeCesium, TimeHub, TimePictra, TimeProvider, TrueTime, and ZL are registered trademarks of Microchip Technology Incorporated in the U.S.A.

Adjacent Key Suppression, AKS, Analog-for-the-Digital Age, Any Capacitor, AnyIn, AnyOut, Augmented Switching, BlueSky, BodyCom, Clockstudio, CodeGuard, CryptoAuthentication, CryptoAutomotive, CryptoCompanion, CryptoController, dsPICDEM, dsPICDEM.net, Dynamic Average Matching, DAM, ECAN, Espresso T1S, EtherGREEN, GridTime, IdealBridge, In-Circuit Serial Programming, ICSP, INICnet, Intelligent Paralleling, IntelliMOS, Inter-Chip Connectivity, JitterBlocker, Knob-on-Display, KoD, maxCrypto, maxView, memBrain, Mindi, MiWi, MPASM, MPF, MPLAB Certified logo, MPLIB, MPLINK, MultiTRAK, NetDetach, Omniscient Code Generation, PICDEM, PICDEM.net, PICkit, PICtail, PowerSmart, PureSilicon, QMatrix, REAL ICE, Ripple Blocker, RTAX, RTG4, SAM-ICE, Serial Quad I/O, simpleMAP, SimpliPHY, SmartBuffer, SmartHLS, SMART-I.S., storClad, SQI, SuperSwitcher, SuperSwitcher II, Switchtec, SynchroPHY, Total Endurance, Trusted Time, TSHARC, USBCheck, VariSense, VectorBlox, VeriPHY, ViewSpan, WiperLock, XpressConnect, and ZENA are trademarks of Microchip Technology Incorporated in the U.S.A. and other countries.

SQTP is a service mark of Microchip Technology Incorporated in the U.S.A.

The Adaptec logo, Frequency on Demand, Silicon Storage Technology, and Symmcom are registered trademarks of Microchip Technology Inc. in other countries.

GestIC is a registered trademark of Microchip Technology Germany II GmbH & Co. KG, a subsidiary of Microchip Technology Inc., in other countries.

All other trademarks mentioned herein are property of their respective companies.

© 2022, Microchip Technology Incorporated and its subsidiaries.

All Rights Reserved.

ISBN: 978-1-6683-0831-8



MICROCHIP

Worldwide Sales and Service

AMERICAS

Corporate Office
2355 West Chandler Blvd.
Chandler, AZ 85224-6199
Tel: 480-792-7200
Fax: 480-792-7277
Technical Support:
<http://www.microchip.com/support>
Web Address:
www.microchip.com

Atlanta
Duluth, GA
Tel: 678-957-9614
Fax: 678-957-1455

Austin, TX
Tel: 512-257-3370

Boston
Westborough, MA
Tel: 774-760-0087
Fax: 774-760-0088

Chicago
Itasca, IL
Tel: 630-285-0071
Fax: 630-285-0075

Dallas
Addison, TX
Tel: 972-818-7423
Fax: 972-818-2924

Detroit
Novi, MI
Tel: 248-848-4000

Houston, TX
Tel: 281-894-5983

Indianapolis
Noblesville, IN
Tel: 317-773-8323
Fax: 317-773-5453
Tel: 317-536-2380

Los Angeles
Mission Viejo, CA
Tel: 949-462-9523
Fax: 949-462-9608
Tel: 951-273-7800

Raleigh, NC
Tel: 919-844-7510

New York, NY
Tel: 631-435-6000

San Jose, CA
Tel: 408-735-9110
Tel: 408-436-4270

Canada - Toronto
Tel: 905-695-1980
Fax: 905-695-2078

ASIA/PACIFIC

Australia - Sydney
Tel: 61-2-9868-6733

China - Beijing
Tel: 86-10-8569-7000

China - Chengdu
Tel: 86-28-8665-5511

China - Chongqing
Tel: 86-23-8980-9588

China - Dongguan
Tel: 86-769-8702-9880

China - Guangzhou
Tel: 86-20-8755-8029

China - Hangzhou
Tel: 86-571-8792-8115

China - Hong Kong SAR
Tel: 852-2943-5100

China - Nanjing
Tel: 86-25-8473-2460

China - Qingdao
Tel: 86-532-8502-7355

China - Shanghai
Tel: 86-21-3326-8000

China - Shenyang
Tel: 86-24-2334-2829

China - Shenzhen
Tel: 86-755-8864-2200

China - Suzhou
Tel: 86-186-6233-1526

China - Wuhan
Tel: 86-27-5980-5300

China - Xian
Tel: 86-29-8833-7252

China - Xiamen
Tel: 86-592-2388138

China - Zhuhai
Tel: 86-756-3210040

ASIA/PACIFIC

India - Bangalore
Tel: 91-80-3090-4444

India - New Delhi
Tel: 91-11-4160-8631

India - Pune
Tel: 91-20-4121-0141

Japan - Osaka
Tel: 81-6-6152-7160

Japan - Tokyo
Tel: 81-3-6880-3770

Korea - Daegu
Tel: 82-53-744-4301

Korea - Seoul
Tel: 82-2-554-7200

Malaysia - Kuala Lumpur
Tel: 60-3-7651-7906

Malaysia - Penang
Tel: 60-4-227-8870

Philippines - Manila
Tel: 63-2-634-9065

Singapore
Tel: 65-6334-8870

Taiwan - Hsin Chu
Tel: 886-3-577-8366

Taiwan - Kaohsiung
Tel: 886-7-213-7830

Taiwan - Taipei
Tel: 886-2-2508-8600

Thailand - Bangkok
Tel: 66-2-694-1351

Vietnam - Ho Chi Minh
Tel: 84-28-5448-2100

EUROPE

Austria - Wels
Tel: 43-7242-2244-39
Fax: 43-7242-2244-393

Denmark - Copenhagen
Tel: 45-4485-5910
Fax: 45-4485-2829

Finland - Espoo
Tel: 358-9-4520-820

France - Paris
Tel: 33-1-69-53-63-20
Fax: 33-1-69-30-90-79

Germany - Garching
Tel: 49-8931-9700

Germany - Haan
Tel: 49-2129-3766400

Germany - Heilbronn
Tel: 49-7131-72400

Germany - Karlsruhe
Tel: 49-721-625370

Germany - Munich
Tel: 49-89-627-144-0
Fax: 49-89-627-144-44

Germany - Rosenheim
Tel: 49-8031-354-560

Israel - Ra'anana
Tel: 972-9-744-7705

Italy - Milan
Tel: 39-0331-742611
Fax: 39-0331-466781

Italy - Padova
Tel: 39-049-7625286

Netherlands - Drunen
Tel: 31-416-690399
Fax: 31-416-690340

Norway - Trondheim
Tel: 47-7288-4388

Poland - Warsaw
Tel: 48-22-3325737

Romania - Bucharest
Tel: 40-21-407-87-50

Spain - Madrid
Tel: 34-91-708-08-90
Fax: 34-91-708-08-91

Sweden - Gothenberg
Tel: 46-31-704-60-40

Sweden - Stockholm
Tel: 46-8-5090-4654

UK - Wokingham
Tel: 44-118-921-5800
Fax: 44-118-921-5820