



Product Change Notification / JAON-09HVKT693

Date:

13-Feb-2023

Product Category:

32-bit Microcontrollers, Smart Energy SOC

PCN Type:

Manufacturing Change

Notification Subject:

CCB 6142 Initial Notice: Qualification of MPHL as an additional final test site for ATM90E36A-AU-R, ATM90E36A-AU-Y, SWF2L30B-AU-R, and SWF2L30B-AU-Y catalog part numbers (CPN) available in 48L TQFP (7x7x1.0 mm) package.

Affected CPNs:

[JAON-09HVKT693_Affected_CPN_02132023.pdf](#)

[JAON-09HVKT693_Affected_CPN_02132023.csv](#)

Notification Text:

PCN Status:Initial Notification

PCN Type:Manufacturing Change

Microchip Parts Affected:Please open one of the files found in the Affected CPNs section.

Note: For your convenience Microchip includes identical files in two formats (.pdf and .xls)

Description of Change:Qualification of MPHL as an additional final test site for ATM90E36A-AU-R, ATM90E36A-AU-Y, SWF2L30B-AU-R, and SWF2L30B-AU-Y catalog part numbers (CPN) available in 48L TQFP (7x7x1.0 mm) package.

Pre and Post Change Summary:

Qual Report Availability										X		
Final PCN Issue Date										X		

Method to Identify Change:Traceability code

Qualification Plan:Please open the attachments included with this PCN labeled as PCN_#_Qual_Plan.

Revision History:February 13, 2023: Issued initial notification.

The change described in this PCN does not alter Microchip’s current regulatory compliance regarding the material content of the applicable products.

Attachments:

- [PCN_JAON-09HVKT693_Qual Plan.pdf](#)
- [PCN_JAON-09HVKT693_Pre and Post_Change_Summary.pdf](#)

Please contact your local **Microchip sales office** with questions or concerns regarding this notification.

Terms and Conditions:

If you wish to receive Microchip PCNs via email please register for our PCN email service at our **PCN home page** select register then fill in the required fields. You will find instructions about registering for Microchips PCN email service in the **PCN FAQ** section.

If you wish to change your PCN profile, including opt out, please go to the **PCN home page** select login and sign into your myMicrochip account. Select a profile option from the left navigation bar and make the applicable selections.



MICROCHIP

QUALIFICATION PLAN SUMMARY

PCN#: JAON-09HVKT693

**Date:
February 9, 2023**

Qualification of MPHL as an additional final test site for ATM90E36A-AU-R, ATM90E36A-AU-Y, SWF2L30B-AU-R, and SWF2L30B-AU-Y catalog part numbers (CPN) available in 48L TQFP (7x7x1.0 mm) package.

Purpose: Qualification of MPHL as an additional final test site for ATM90E36A-AU-R, ATM90E36A-AU-Y, SWF2L30B-AU-R, and SWF2L30B-AU-Y catalog part numbers (CPN) available in 48L TQFP (7x7x1.0 mm) package.

CCB#: 6142

Test /Evaluation	Test Condition/Parameters
Original Final Test Site Correlation	Run 3,000 devices to the final test flows at the original site and keep the good devices and rejects in separate bins.
Original Final Test Site Characterization	Characterize 33 good devices at the original test site with DC items and measurable functional test items which are specified in the product datasheet (ex. Tce, Icc, Isb, Vih, Vil, Voh, Vol) and send these devices to the destination final test site.
Destination Final Test Site Characterization	Re-characterize the same 33 good devices at the destination test site using the destination site hardware/programs for the same DC and measurable functional test items. The results will be accepted if the variance within $\pm 10\%$ of the measured values from the original test site.
Destination Final Test Site Correlation	Send 3,000 tested parts to the destination test site. The results need 100% correlation to continue the release flow.
Destination Final Test Site Cross Correlation	Run 33 untested devices from the destination test site with same FT program; keep the good devices and rejects separate by bins and send all devices to the original test site for correlation. Re-test those 33 devices from destination test site bin- by-bin to the same FT program for correlation. The yield difference should be within 0.1% and bin-to-bin difference should be within 0.1%

JAON-09HVKT693 - CCB 6142 Initial Notice: Qualification of MPHL as an additional final test site for ATM90E36A-AU-R, ATM90E36A-AU-Y, SWF2L30B-AU-R, and SWF2L30B-AU-Y catalog part numbers (CPN) available in 48L TQFP (7x7x1.0 mm) package.

Affected Catalog Part Numbers (CPN)

ATM90E36A-AU-R

ATM90E36A-AU-Y

SWF2L30B-AU-R

SWF2L30B-AU-Y

CCB 6142

Pre and Post Change Summary

PCN #: JAON-09HVKT693



A Leading Provider of Smart, Connected and Secure Embedded Control Solutions

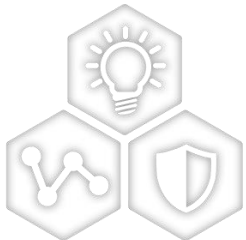

SMART | CONNECTED | SECURE

Tape and Reel – Cover Tape

ASE9

MPHL

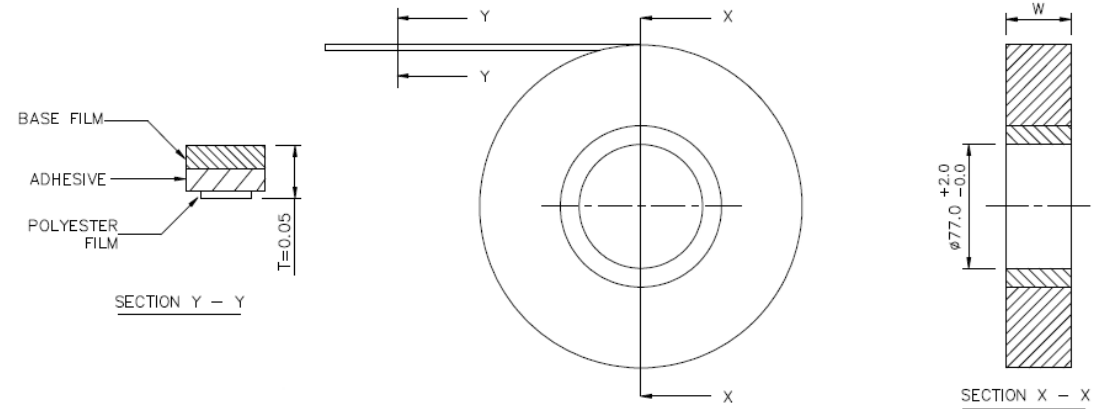
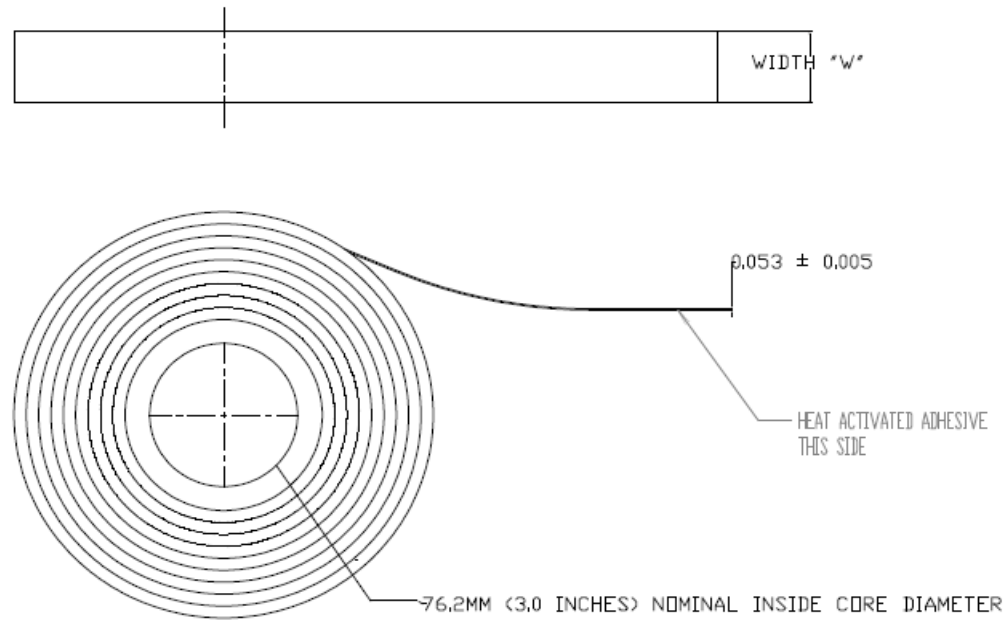

Cover Tape PSA
W: 13.3 mm
P/N: 211893

Plant	Carrier Width	Cover tape Width "W" (mm)	Thickness (mm)	Sealing Methodology
ASE9	16	13.3	0.053	Heat
MPHL	16	13.3	0.045 – 0.055	Pressure

Tape and Reel - Reel

ASE9



MPHL



Plant	For Carrier Tape Width	Diameter	Hub	Color
ASE9	16	330	102	WHITE
MPHL	16	330	100	WHITE

Tape and Reel – Packing Method

ASE9

1

LABEL



3



Cardboard

Bubble Wrap



2

HIC

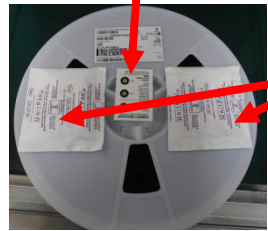

Desiccant X2

1st Sealing Area
(upper 2nd solid line)

Dry pack bag hole
direction



MBB inner box label

4

MSID
sticker



Inner Box
Label

2D label

MPHL

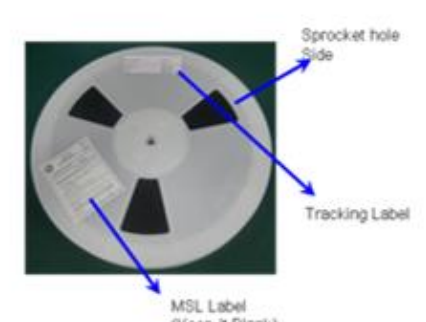
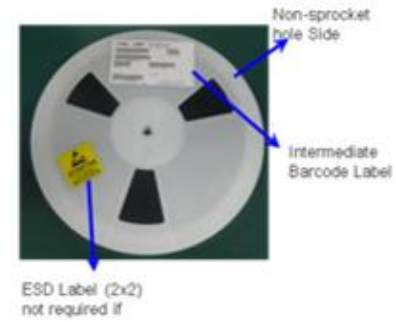

TRAY

ASE9

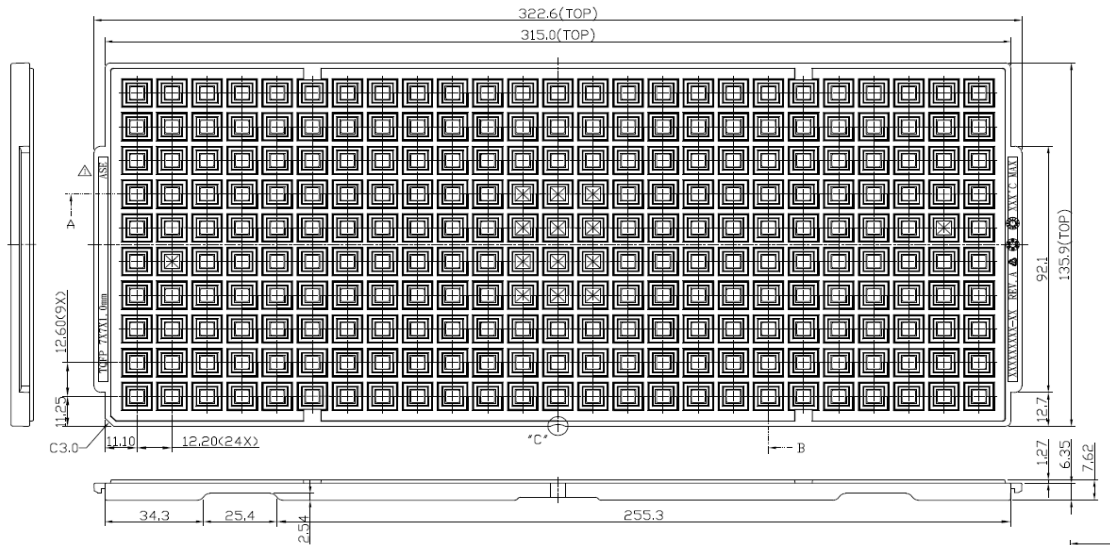

Pin 1 Orientation

1D

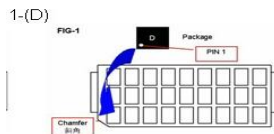

MPHL

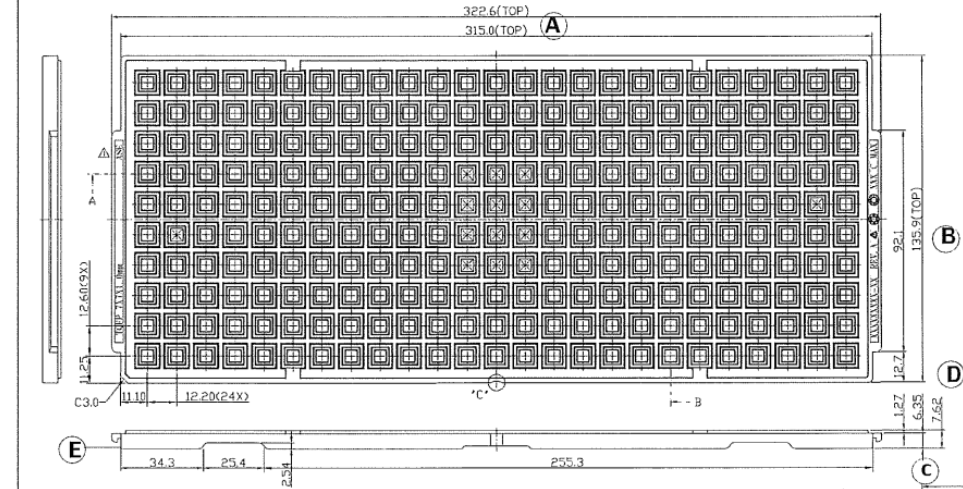

Pin 1 Orientation

Near CHAMFER SIDE

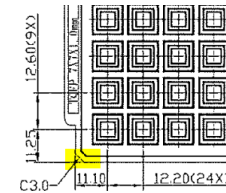

Plant	Length – max outer (mm)	Width – max outer (mm)	Thickness – max (mm)	Color	BQM
ASE9	315	135.9	7.62	BLACK	250
MPHL	315	135.9	7.62	BLACK	250

TRAY – Packing Method

ASE9

1

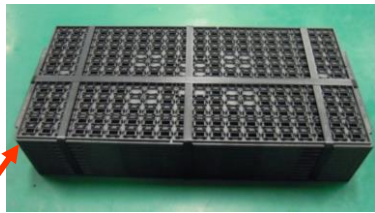

CHAMFER
斜角

3



Bubble Wrap
粉紅氣泡布

10+1 stack
STRAPS (3S1L)
打包帶 (3短1長)

HIC 溼度指示卡



2

Chamfer
斜角

Desiccant 1 units x 2
1單位乾燥劑 x2 inner box Label
真空袋標籤

MBB
真空袋



4

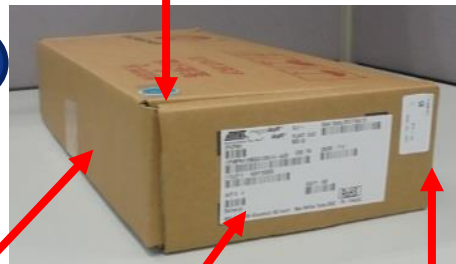

膠帶
Tape

Tray Inner
Box Label
內盒標籤

ASET small
bar code
ASET2維小標
籤

MSID sticker
MSID 標籤

MPHL



Max: 10 full trays + 1 empty tray cover
PP Strapping: 3 crosswise & 1 lengthwise



Desiccant
(1.0 unit)

HIC (Humidity
Indicator Card)

Desiccant
(1.0 unit)

Open Side

Intermediate
Barcode Label

MSL (Caution)
Label

ESD Label
(2x2)



Bubble Sheet



Open Side
of Box

Intermediate
Label