

4<sup>th</sup> November 2022

## Change of package and quantity per carton of BR-3032/BN and CR-3032/BN

Our packing drop test is conducted according to Panasonic standards, which are more severe than the UN standards. Additional testing of BR-3032/BN resulted in minor problems. In preparation for problems during transportation and storage, we decided to take an urgent countermeasure to strengthen the impact resistance according to our quality policy. Also, we will increase the quantity per carton, responding to the request from some customers. Below is the overview of the change.

■ Model Number: BR-3032/BN and CR-3032/BN

■ Step-1 Change the gap filling material

Purpose : Improved impact resistance

Before : Air pillows are used as gap filling material

After : Introduced a packing form that does not require air pillows by changing the gap filling material to pad.

■ Timing : From middle of November 2022 onwards Ex-Factory base

■ Step-2 Quantity per carton

Purpose : Increase loading efficiency and removal of gap filling materials

Before : Box size(198x291x132) / 200pcs per carton

After : Box size(234x194x161) / 400pcs per carton

■ Timing : From beginning of February 2023 onwards Ex-Factory base

Remarks) Regarding Step-2, we will also revise the display changes due to the revision of the transportation regulation related to lithium batteries.

Item		Current	Step-1	Step-2
Product number		BR-3032/BN CR-3032/BN	BR-3032/BN CR-3032/BN	BR-3032/BN CR-3032/BN
Battery qty./carton		200 pcs	200 pcs	400 pcs
Outer carton size		198×291×132 mm	198×291×132 mm	(234x194x161 mm)
Gross weight	BR-3032/BN	1.39 kg	1.89 kg	(2.79 kg)
	CR-3032/BN	1.64 kg	2.15 kg	(3.04 kg)
Air cushion		Use	No use	No use
Pad		No use	Pad	(No use)

If you have any question, please feel free to contact your Panasonic sales representative.

Sincerely,

Energy Device Business Division

# Proposal packing specification of outer carton

Current

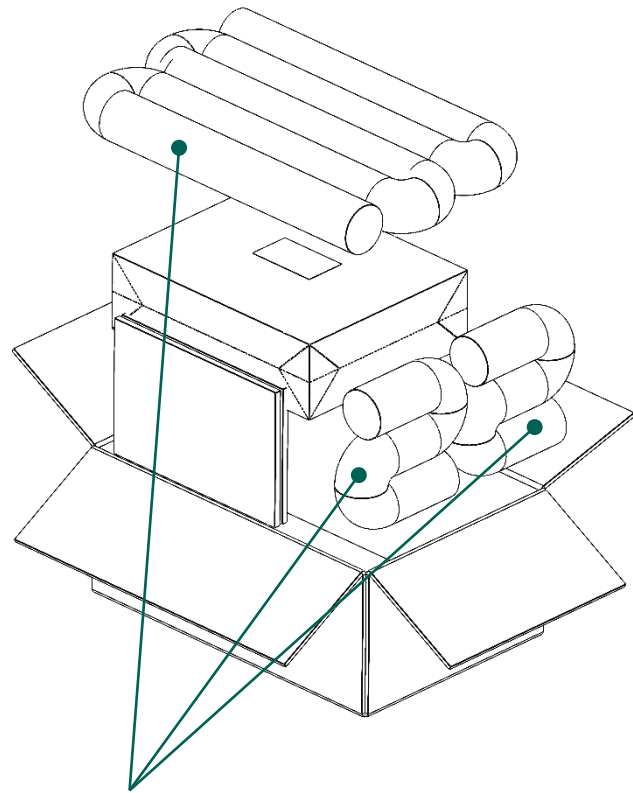

**Air cushion**

Step-1

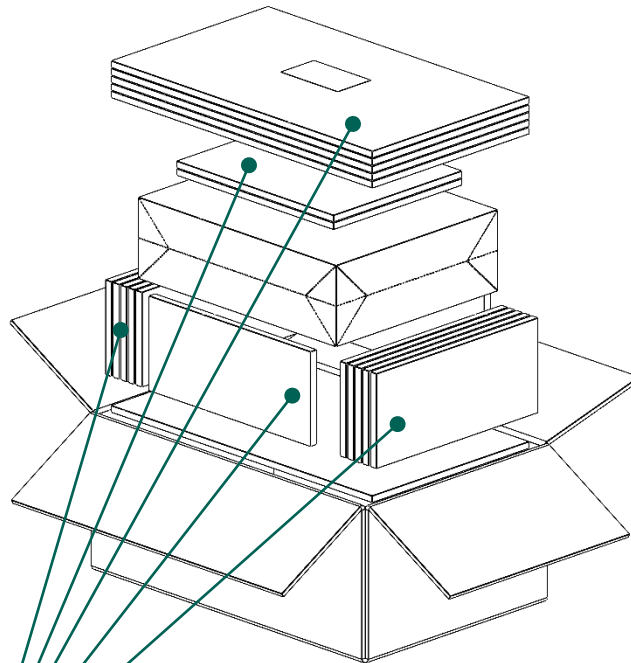

**Pad**

※Pad qty. is reference

Step-2

