



## Product Change Notification / SYST-02TWJB455

---

**Date:**

09-Jun-2022

**Product Category:**

Memory

**PCN Type:**

Document Change

**Notification Subject:**

Data Sheet - AT24C256C I<sup>2</sup>C-Compatible (Two-Wire) Serial EEPROM 256-Kbit (32,768 x 8) Data Sheet Document Revision

**Affected CPNs:**

[SYST-02TWJB455\\_Affected\\_CPN\\_06092022.pdf](#)  
[SYST-02TWJB455\\_Affected\\_CPN\\_06092022.csv](#)

**Notification Text:**

SYST-02TWJB455

Microchip has released a new Datasheet for the AT24C256C I<sup>2</sup>C-Compatible (Two-Wire) Serial EEPROM 256-Kbit (32,768 x 8) of devices. If you are using one of these devices please read the document located at [AT24C256C I<sup>2</sup>C-Compatible \(Two-Wire\) Serial EEPROM 256-Kbit \(32,768 x 8\)](#).

**Notification Status:** Final

**Description of Change:**

1) Updated section content throughout for clarification. Added note to Table 4-6 that explains the array architecture and how endurance is specified. Updated Part Marking information. Updated the SOIC, TSSOP and UDFN package drawings. Updated "master" and "slave" terminology with "host" and "client" respectively.

**Impacts to Data Sheet:** See above details.

**Reason for Change:** To Improve Productivity

**Change Implementation Status:** Complete

**Date Document Changes Effective:** 09 June 2022

**NOTE:** Please be advised that this is a change to the document only the product has not been changed.

**Markings to Distinguish Revised from Unrevised Devices:** N/A

## **Attachments:**

[AT24C256C I<sup>2</sup>C-Compatible \(Two-Wire\) Serial EEPROM 256-Kbit \(32,768 x 8\)](#)

Please contact your local [Microchip sales office](#) with questions or concerns regarding this notification.

## **Terms and Conditions:**

If you wish to receive Microchip PCNs via email please register for our PCN email service at our [PCN home page](#) select register then fill in the required fields. You will find instructions about registering for Microchips PCN email service in the [PCN FAQ](#) section.

If you wish to change your PCN profile, including opt out, please go to the [PCN home page](#) select login and sign into your myMicrochip account. Select a profile option from the left navigation bar and make the applicable selections.



# AT24C256C

---

---

## I<sup>2</sup>C-Compatible (Two-Wire) Serial EEPROM 256-Kbit (32,768 x 8)

---

---

### Features

---

- Low-Voltage and Standard-Voltage Operation:
  - $V_{CC} = 1.7V$  to  $5.5V$
- Internally Organized as 32,768 x 8 (256K)
- Industrial Temperature Range:  $-40^{\circ}C$  to  $+85^{\circ}C$
- I<sup>2</sup>C-Compatible (Two-Wire) Serial Interface:
  - 100 kHz Standard mode, 1.7V to 5.5V
  - 400 kHz Fast mode, 1.7V to 5.5V
  - 1 MHz Fast Mode Plus (FM+), 2.5V to 5.5V
- Schmitt Triggers, Filtered Inputs for Noise Suppression
- Bidirectional Data Transfer Protocol
- Write-Protect Pin for Full Array Hardware Data Protection
- Ultra Low Active Current (3 mA maximum) and Standby Current (6  $\mu A$  maximum)
- 64-Byte Page Write Mode:
  - Partial page writes allowed
- Random and Sequential Read Modes
- Self-Timed Write Cycle within 5 ms Maximum
- ESD Protection  $>4,000V$
- High Reliability:
  - Endurance: 1,000,000 write cycles
  - Data retention: 100 years
- Green Package Options (Lead-free/Halide-free/RoHS compliant)
- Die Sale Options: Wafer Form and Bumped Wafers

### Packages

---

- 8-Lead SOIC, 8-Lead TSSOP, 8-Pad UDFN and 8-Ball VFBGA

## Table of Contents

Features.....	1
Packages.....	1
1. Package Types (not to scale).....	4
2. Pin Descriptions.....	5
2.1. Device Address Inputs (A0, A1, A2).....	5
2.2. Ground.....	5
2.3. Serial Data (SDA).....	5
2.4. Serial Clock (SCL).....	5
2.5. Write-Protect (WP).....	5
2.6. Device Power Supply.....	6
3. Description.....	7
3.1. System Configuration Using Two-Wire Serial EEPROMs .....	7
3.2. Block Diagram.....	8
4. Electrical Characteristics.....	9
4.1. Absolute Maximum Ratings.....	9
4.2. DC and AC Operating Range.....	9
4.3. DC Characteristics.....	9
4.4. AC Characteristics.....	10
4.5. Electrical Specifications.....	11
5. Device Operation and Communication.....	13
5.1. Clock and Data Transition Requirements.....	13
5.2. Start and Stop Conditions.....	13
5.3. Acknowledge and No-Acknowledge.....	14
5.4. Standby Mode.....	14
5.5. Software Reset.....	14
6. Memory Organization.....	16
6.1. Device Addressing.....	16
7. Write Operations.....	17
7.1. Byte Write.....	17
7.2. Page Write.....	17
7.3. Acknowledge Polling.....	18
7.4. Write Cycle Timing.....	18
7.5. Write Protection.....	19
8. Read Operations.....	20
8.1. Current Address Read.....	20
8.2. Random Read.....	20
8.3. Sequential Read.....	21
9. Device Default Condition from Microchip.....	22

10. Packaging Information.....	23
10.1. Package Marking Information.....	23
11. Revision History.....	34
The Microchip Website.....	35
Product Change Notification Service.....	35
Customer Support.....	35
Product Identification System.....	36
Microchip Devices Code Protection Feature.....	36
Legal Notice.....	37
Trademarks.....	37
Quality Management System.....	38
Worldwide Sales and Service.....	39

### 1. Package Types (not to scale)

**8-Pad UDFN**  
(Top View)

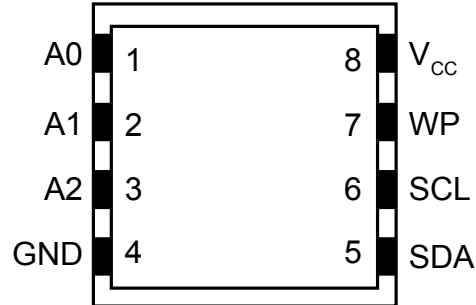

**8-Lead SOIC/TSSOP**  
(Top View)

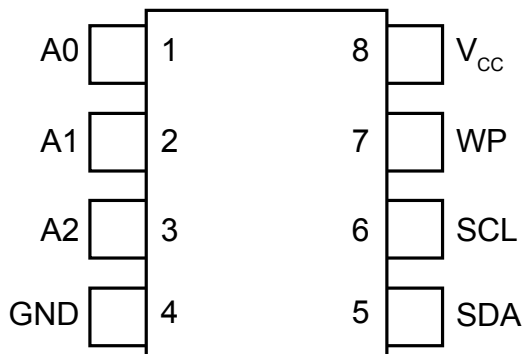

**8-Ball VFBGA**  
(Top View)

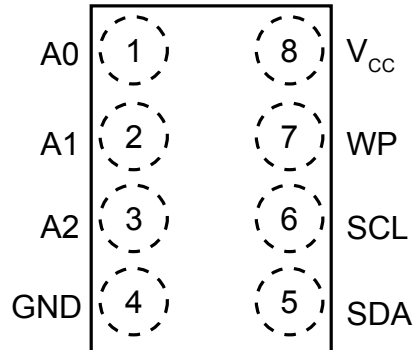

## 2. Pin Descriptions

The descriptions of the pins are listed in [Table 2-1](#).

**Table 2-1. Pin Function Table**

Name	8-Lead SOIC	8-Lead TSSOP	8-Pad UDFN <sup>(1)</sup>	8-Ball VFBGA	Function
A0 <sup>(2)</sup>	1	1	1	1	Device Address Input
A1 <sup>(2)</sup>	2	2	2	2	Device Address Input
A2 <sup>(2)</sup>	3	3	3	3	Device Address Input
GND	4	4	4	4	Ground
SDA	5	5	5	5	Serial Data
SCL	6	6	6	6	Serial Clock
WP <sup>(2)</sup>	7	7	7	7	Write-Protect
VCC	8	8	8	8	Device Power Supply

### Notes:

1. The exposed pad on this package can be connected to GND or left floating.
2. If the A0, A1, A2 or WP pins are not driven, they are internally pulled down to GND. In order to operate in a wide variety of application environments, the pull-down mechanism is intentionally designed to be somewhat strong. Once these pins are biased above the CMOS input buffer's trip point ( $\sim 0.5 \times V_{CC}$ ), the pull-down mechanism disengages. Microchip recommends connecting these pins to a known state whenever possible.

### 2.1 Device Address Inputs (A0, A1, A2)

The A0, A1 and A2 pins are device address inputs that are hard-wired (directly to GND or to  $V_{CC}$ ) for compatibility with other two-wire Serial EEPROM devices. When the pins are hard-wired, as many as eight devices may be addressed on a single bus system. A device is selected when a corresponding hardware and software match is true. If these pins are left floating, the A0, A1 and A2 pins will be internally pulled down to GND. However, due to capacitive coupling that may appear in customer applications, Microchip recommends always connecting the address pins to a known state. When using a pull-up resistor, Microchip recommends using 10 k $\Omega$  or less.

### 2.2 Ground

The ground reference for the power supply. GND should be connected to the system ground.

### 2.3 Serial Data (SDA)

The SDA pin is an open-drain bidirectional input/output pin used to serially transfer data to and from the device. The SDA pin must be pulled high using an external pull-up resistor (not to exceed 10 k $\Omega$  in value) and may be wire-ORed with any number of other open-drain or open-collector pins from other devices on the same bus.

### 2.4 Serial Clock (SCL)

The SCL pin is used to provide a clock to the device and to control the flow of data to and from the device. Command and input data present on the SDA pin is always latched in on the rising edge of SCL, while output data on the SDA pin is clocked out on the falling edge of SCL. The SCL pin must either be forced high when the serial bus is idle or pulled high using an external pull-up resistor.

### 2.5 Write-Protect (WP)

The write-protect input, when connected to GND, allows normal write operations. When the WP pin is connected directly to  $V_{CC}$ , all write operations to the protected memory are inhibited.

If the pin is left floating, the WP pin will be internally pulled down to GND. However, due to capacitive coupling that may appear in customer applications, Microchip recommends always connecting the WP pin to a known state. When using a pull-up resistor, Microchip recommends using 10 kΩ or less.

**Table 2-2. Write-Protect**

WP Pin Status	Part of the Array Protected
At $V_{CC}$	Full Array
At GND	Normal Write Operations

## 2.6 Device Power Supply

The  $V_{CC}$  pin is used to supply the source voltage to the device. Operations at invalid  $V_{CC}$  voltages may produce spurious results and should not be attempted.



### 3. Description

The AT24C256C provides 262,144 bits of Serial Electrically Erasable and Programmable Read-Only Memory (EEPROM) organized as 32,768 words of 8 bits each. The device's cascading feature allows up to eight devices to share a common two-wire bus. The device is optimized for use in many industrial and commercial applications where low-power and low-voltage operation are essential. The devices are available in space-saving 8-lead SOIC, 8-lead TSSOP, 8-pad UDFN and 8-ball VFBGA packages. All packages operate from 1.7V to 5.5V.

#### 3.1 System Configuration Using Two-Wire Serial EEPROMs

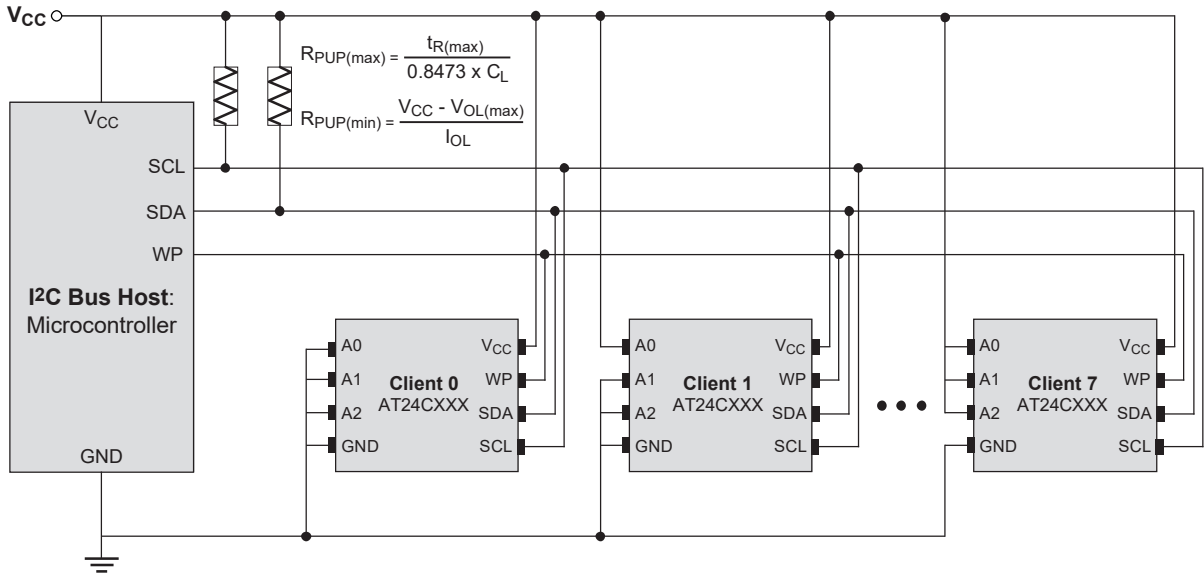

3.2 Block Diagram

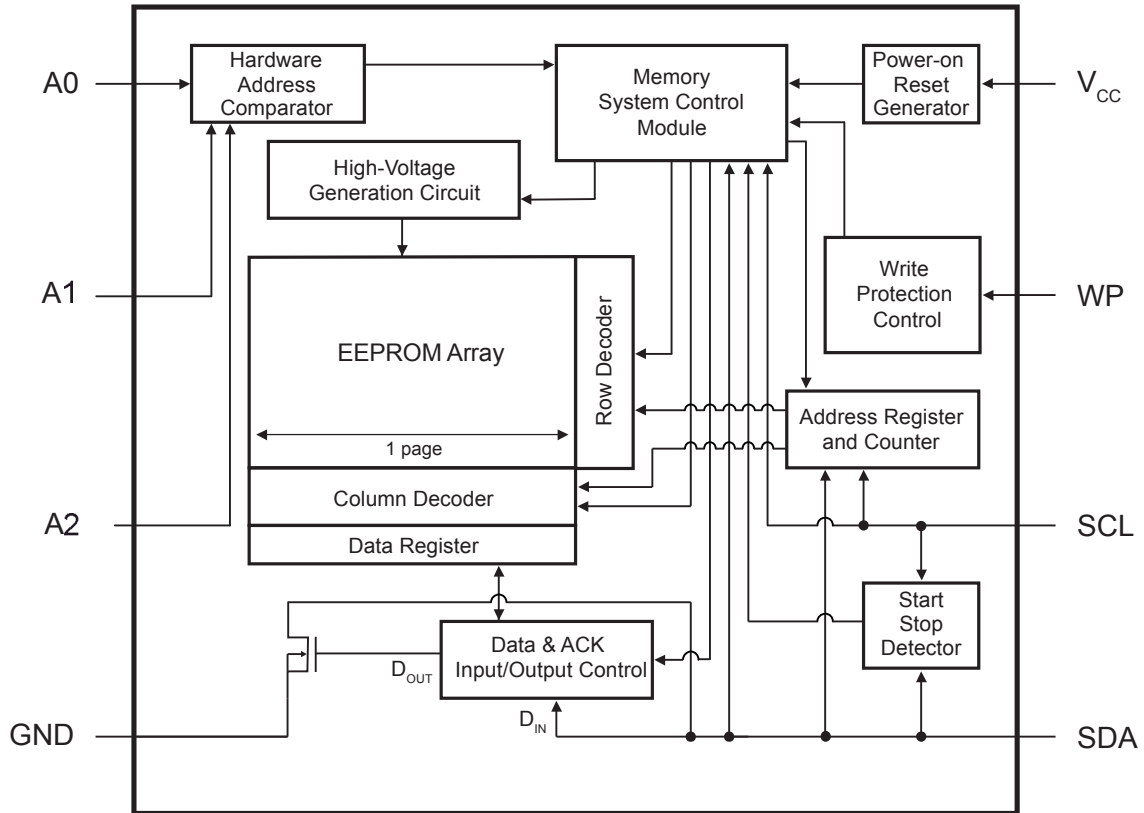

## 4. Electrical Characteristics

### 4.1 Absolute Maximum Ratings

Temperature under bias	-55°C to +125°C
Storage temperature	-65°C to +150°C
V <sub>CC</sub>	6.25V
Voltage on any pin with respect to ground	-1.0V to +7.0V
DC output current	5.0 mA
ESD protection	>4 kV

**Note:** Stresses above those listed under “Absolute Maximum Ratings” may cause permanent damage to the device. This is a stress rating only and functional operation of the device at these or any other conditions above those indicated in the operation listings of this specification is not implied. Exposure to absolute maximum rating conditions for extended periods may affect device reliability.

### 4.2 DC and AC Operating Range

Table 4-1. DC and AC Operating Range

AT24C256C		
Operating Temperature (Case)	Industrial Temperature Range	-40°C to +85°C
V <sub>CC</sub> Power Supply	Low-Voltage Grade	1.7V to 5.5V

### 4.3 DC Characteristics

Table 4-2. DC Characteristics

Parameter	Symbol	Minimum	Typical <sup>(1)</sup>	Maximum	Units	Test Conditions
Supply Voltage	V <sub>CC1</sub>	1.7	—	5.5	V	
Supply Current	I <sub>CC1</sub>	—	1.0	2.0	mA	V <sub>CC</sub> = 5.0V, Read at 400 kHz
Supply Current	I <sub>CC2</sub>	—	2.0	3.0	mA	V <sub>CC</sub> = 5.0V, Write at 400 kHz
Standby Current	I <sub>SB1</sub>	—	—	1.0	μA	V <sub>CC</sub> = 1.7V, V <sub>IN</sub> = V <sub>CC</sub> or GND
		—	—	6.0	μA	V <sub>CC</sub> = 5.0V, V <sub>IN</sub> = V <sub>CC</sub> or GND
Input Leakage Current	I <sub>LI</sub>	—	0.10	3.0	μA	V <sub>IN</sub> = V <sub>CC</sub> or GND; V <sub>CC</sub> = 5.0V
Output Leakage Current	I <sub>LO</sub>	—	0.05	3.0	μA	V <sub>OUT</sub> = V <sub>CC</sub> or GND; V <sub>CC</sub> = 5.0V
Input Low Level	V <sub>IL</sub>	-0.6	—	V <sub>CC</sub> × 0.3	V	<a href="#">Note 2</a>
Input High Level	V <sub>IH</sub>	V <sub>CC</sub> × 0.7	—	V <sub>CC</sub> + 0.5	V	<a href="#">Note 2</a>
Output Low Level	V <sub>OL1</sub>	—	—	0.2	V	V <sub>CC</sub> = 1.7V, I <sub>OL</sub> = 0.15 mA
Output Low Level	V <sub>OL2</sub>	—	—	0.4	V	V <sub>CC</sub> = 3.0V, I <sub>OL</sub> = 2.1 mA

**Notes:**

1. Typical values characterized at  $T_A = +25^\circ\text{C}$  unless otherwise noted.
2. This parameter is characterized but is not 100% tested in production.

## 4.4 AC Characteristics

**Table 4-3. AC Characteristics<sup>(1)</sup>**

Parameter	Symbol	Fast Mode		Fast Mode Plus		Units
		$V_{CC} = 1.7\text{V to }2.5\text{V}$		$V_{CC} = 1.7\text{V to }5.5\text{V}$		
		Minimum	Maximum	Minimum	Maximum	
Clock Frequency, SCL	$f_{SCL}$	—	400	—	1000	kHz
Clock Pulse Width Low	$t_{LOW}$	1300	—	500	—	ns
Clock Pulse Width High	$t_{HIGH}$	600	—	400	—	ns
Noise Suppression Time <sup>(2)</sup>	$t_I$	—	100	—	50	ns
Clock Low to Data Out Valid	$t_{AA}$	50	900	50	450	ns
Bus Free Time between Stop and Start <sup>(2)</sup>	$t_{BUF}$	1300	—	500	—	ns
Start Hold Time	$t_{HD.STA}$	600	—	250	—	ns
Start Set-up Time	$t_{SU.STA}$	600	—	250	—	ns
Data In Hold Time	$t_{HD.DAT}$	0	—	0	—	ns
Data In Set-up Time	$t_{SU.DAT}$	100	—	100	—	ns
Inputs Rise Time <sup>(2)</sup>	$t_R$	—	300	—	300	ns
Inputs Fall Time <sup>(2)</sup>	$t_F$	—	300	—	100	ns
Stop Set-up Time	$t_{SU.STO}$	600	—	250	—	ns
Data Out Hold Time	$t_{DH}$	50	—	50	—	ns
Write Cycle Time	$t_{WR}$	—	5	—	5	ms

**Notes:**

1. AC measurement conditions:
  - $C_L$ : 100 pF
  - $R_{PUP}$  (SDA bus line pull-up resistor to  $V_{CC}$ ): 1.3 k $\Omega$  (1000 kHz), 4 k $\Omega$  (400 kHz), 10 k $\Omega$  (100 kHz)
  - Input pulse voltages: 0.3  $V_{CC}$  to 0.7  $V_{CC}$
  - Input rise and fall times:  $\leq 50$  ns
  - Input and output timing reference voltages:  $0.5 \times V_{CC}$
2. This parameter is ensured by characterization and is not 100% tested.

**Figure 4-1. Bus Timing**

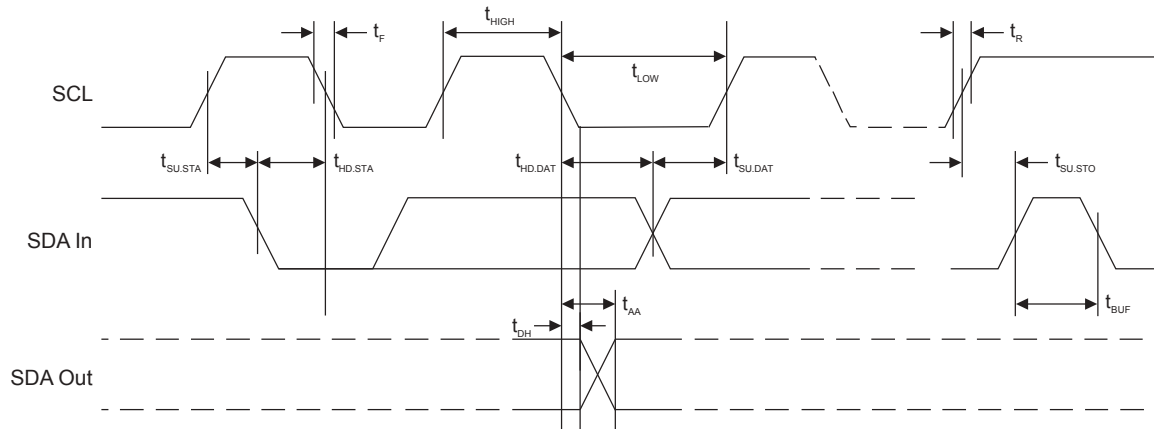

## 4.5 Electrical Specifications

### 4.5.1 Power-Up Requirements and Reset Behavior

During a power-up sequence, the  $V_{CC}$  supplied to the AT24C256C should monotonically rise from GND to the minimum  $V_{CC}$  level (as specified in Table 4-1), with a slew rate no faster than 0.1 V/ $\mu$ s.

#### 4.5.1.1 Device Reset

To prevent inadvertent write operations or any other spurious events from occurring during a power-up sequence, the AT24C256C includes a Power-on Reset (POR) circuit. Upon power-up, the device will not respond to any commands until the  $V_{CC}$  level crosses the internal voltage threshold ( $V_{POR}$ ) that brings the device out of Reset and into Standby mode.

The system designer must ensure the instructions are not sent to the device until the  $V_{CC}$  supply has reached a stable value greater than or equal to the minimum  $V_{CC}$  level. Additionally, once the  $V_{CC}$  is greater than or equal to the minimum  $V_{CC}$  level, the bus host must wait at least  $t_{PUP}$  before sending the first command to the device. See Table 4-4 for the values associated with these power-up parameters.

**Table 4-4. Power-Up Conditions<sup>(1)</sup>**

Symbol	Parameter	Min.	Max.	Units
$t_{PUP}$	Time required after $V_{CC}$ is stable before the device can accept commands	100	—	$\mu$ s
$V_{POR}$	Power-on Reset Threshold Voltage	—	1.5	V
$t_{POFF}$	Minimum time at $V_{CC} = 0V$ between power cycles	500	—	ms

**Note:**

- These parameters are characterized but they are not 100% tested in production.

If an event occurs in the system where the  $V_{CC}$  level supplied to the AT24C256C drops below the maximum  $V_{POR}$  level specified, it is recommended that a full-power cycle sequence be performed by first driving the  $V_{CC}$  pin to GND, waiting at least the minimum  $t_{POFF}$  time and then performing a new power-up sequence in compliance with the requirements defined in this section.

### 4.5.2 Pin Capacitance

**Table 4-5. Pin Capacitance<sup>(1)</sup>**

Symbol	Test Condition	Max.	Units	Conditions
$C_{I/O}$	Input/Output Capacitance (SDA)	8	pF	$V_{I/O} = 0V$

.....continued				
Symbol	Test Condition	Max.	Units	Conditions
$C_{IN}$	Input Capacitance (A0, A1, A2 and SCL)	6	pF	$V_{IN} = 0V$

**Note:**

- This parameter is characterized but is not 100% tested in production.

### 4.5.3 EEPROM Cell Performance Characteristics

**Table 4-6. EEPROM Cell Performance Characteristics**

Operation	Minimum	Maximum	Units	Test Condition
Write Endurance <sup>(1,2)</sup>	1,000,000	—	Write Cycles	$T_A = 25^\circ C$ , $V_{CC} = 3.3V$
Data Retention <sup>(1)</sup>	100	—	Years	$T_A = 55^\circ C$

**Notes:**

- Performance is determined through characterization and the qualification process.
- Due to the memory array architecture, the Write Cycle Endurance is specified for writes in groups of four data bytes. The beginning of any 4-byte boundaries can be determined by multiplying any integer (N) by four (i.e.,  $4*N$ ). The end address can be found by adding three to the beginning value (i.e.,  $4*N+3$ ).

## 5. Device Operation and Communication

The AT24C256C operates as a client device and utilizes a simple I<sup>2</sup>C-compatible two-wire digital serial interface to communicate with a host controller, commonly referred to as the bus host. The host initiates and controls all read and write operations to the client devices on the serial bus, and both the host and the client devices can transmit and receive data on the bus.

The serial interface is comprised of just two signal lines: Serial Clock (SCL) and Serial Data (SDA). The SCL pin is used to receive the clock signal from the host, while the bidirectional SDA pin is used to receive command and data information from the host as well as to send data back to the host. Data is always latched into the AT24C256C on the rising edge of SCL and always output from the device on the falling edge of SCL. Both the SCL and SDA pins incorporate integrated spike suppression filters and Schmitt Triggers to minimize the effects of input spikes and bus noise.

All command and data information is transferred with the Most Significant bit (MSb) first. During bus communication, one data bit is transmitted every clock cycle, and after eight bits (one byte) of data have been transferred, the receiving device must respond with either an Acknowledge (ACK) or a No-Acknowledge (NACK) response bit during a ninth clock cycle (ACK/NACK clock cycle) generated by the host. Therefore, nine clock cycles are required for every one byte of data transferred. There are no unused clock cycles during any read or write operation, so there must not be any interruptions or breaks in the data stream during each data byte transfer and ACK or NACK clock cycle.

During data transfers, data on the SDA pin must only change while SCL is low and the data must remain stable while SCL is high. If data on the SDA pin changes while SCL is high, then either a Start or a Stop condition will occur. Start and Stop conditions are used to initiate and end all serial bus communication between the host and the client devices. The number of data bytes transferred between a Start and a Stop condition is not limited and is determined by the host. In order for the serial bus to be idle, both the SCL and SDA pins must be in the logic high state at the same time.

### 5.1 Clock and Data Transition Requirements

The SDA pin is an open-drain terminal and therefore must be pulled high with an external pull-up resistor. SCL is an input pin that can either be driven high or pulled high using an external pull-up resistor. Data on the SDA pin may change only during SCL low time periods. Data changes during SCL high periods will indicate a Start or Stop condition as defined below. The relationship of the AC timing parameters with respect to SCL and SDA for the AT24C256C are shown in the timing waveform in [Figure 4-1](#). The AC timing characteristics and specifications are outlined in [4.4. AC Characteristics](#).

### 5.2 Start and Stop Conditions

#### 5.2.1 Start Condition

A Start condition occurs when there is a high-to-low transition on the SDA pin while the SCL pin is at a stable logic '1' state and will bring the device out of Standby mode. The host uses a Start condition to initiate any data transfer sequence; therefore, every command must begin with a Start condition. The device will continuously monitor the SDA and SCL pins for a Start condition but will not respond unless one is detected. Refer to [Figure 5-1](#) for more details.

#### 5.2.2 Stop Condition

A Stop condition occurs when there is a low-to-high transition on the SDA pin while the SCL pin is stable in the logic '1' state.

The host can use the Stop condition to end a data transfer sequence with the AT24C256C, which will subsequently return to Standby mode. The host can also utilize a repeated Start condition instead of a Stop condition to end the current data transfer if the host will perform another operation. Refer to [Figure 5-1](#) for more details.

### 5.3 Acknowledge and No-Acknowledge

After every byte of data is received, the receiving device must confirm to the transmitting device that it has successfully received the data byte by responding with what is known as an Acknowledge (ACK). An ACK is accomplished by the transmitting device first releasing the SDA line at the falling edge of the eighth clock cycle followed by the receiving device responding with a logic '0' during the entire high period of the ninth clock cycle.

When the AT24C256C is transmitting data to the host, the host can indicate that it is done receiving data and wants to end the operation by sending a logic '1' response to the AT24C256C instead of an ACK response during the ninth clock cycle. This is known as a No-Acknowledge (NACK) and is accomplished by the host sending a logic '1' during the ninth clock cycle, at which point the AT24C256C will release the SDA line so the host can then generate a Stop condition.

The transmitting device, which can be the bus host or the Serial EEPROM, must release the SDA line at the falling edge of the eighth clock cycle to allow the receiving device to drive the SDA line to a logic '0' to ACK the previous 8-bit word. The receiving device must release the SDA line at the end of the ninth clock cycle to allow the transmitter to continue sending new data. A timing diagram has been provided in [Figure 5-1](#) to better illustrate these requirements.

**Figure 5-1. Start Condition, Data Transitions, Stop Condition and Acknowledge**

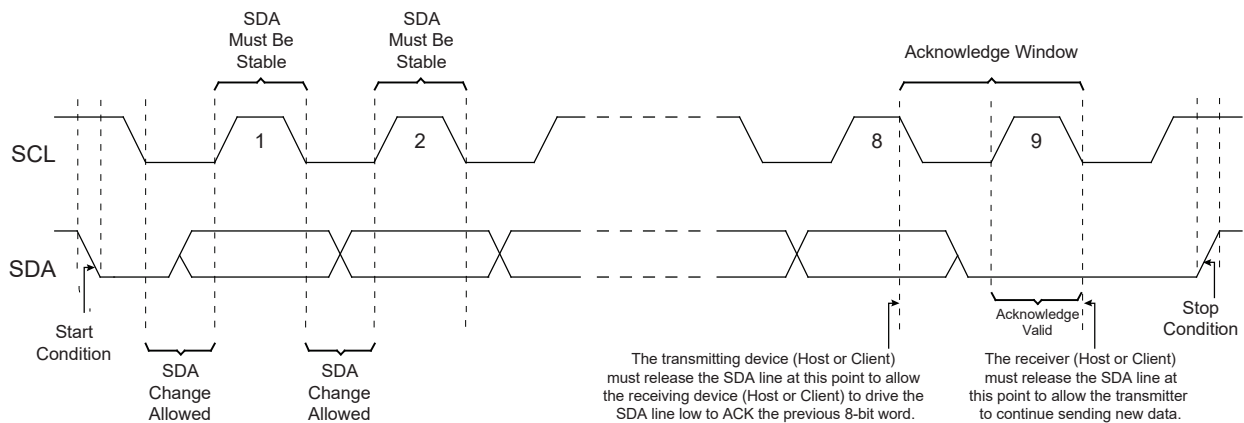

### 5.4 Standby Mode

The AT24C256C features a low-power Standby mode that is enabled when any one of the following occurs:

- A valid power-up sequence is performed (see [4.5.1. Power-Up Requirements and Reset Behavior](#)).
- A Stop condition at the end of a valid I<sup>2</sup>C transaction is received by the device unless it initiates an internal write cycle (see [7. Write Operations](#)).
- At the completion of an internal write cycle (see [7. Write Operations](#)).

### 5.5 Software Reset

After an interruption in protocol, power loss or system Reset, any two-wire device can be protocol reset by clocking SCL until SDA is released by the EEPROM and goes high. The number of clock cycles until SDA is released by the EEPROM will vary. The software Reset sequence should not take more than nine dummy clock cycles. Once the software Reset sequence is complete, new protocol can be sent to the device by sending a Start condition followed by the protocol. Refer to [Figure 5-2](#) for an illustration.



Figure 5-2. Software Reset

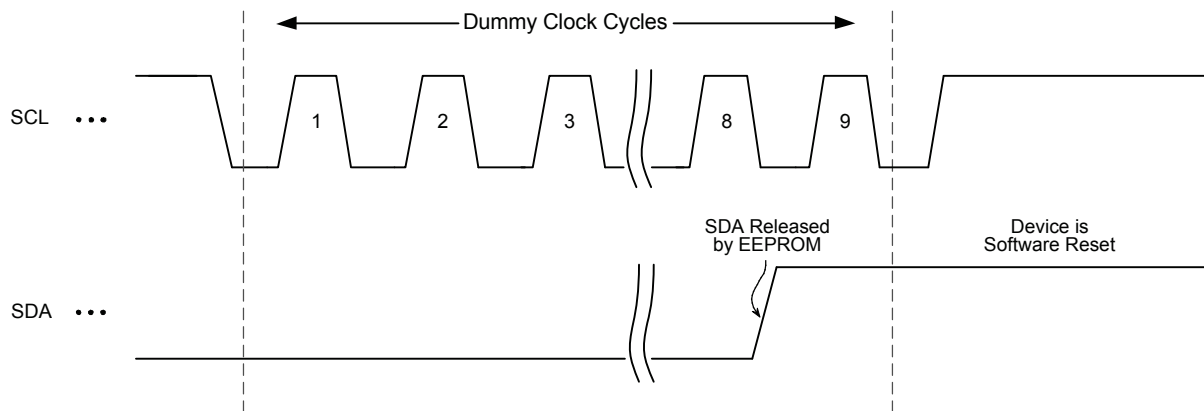

In the event that the device is still non-responsive or remains active on the SDA bus, a power cycle must be used to reset the device (see [Power-Up Requirements and Reset Behavior](#)).

## 6. Memory Organization

The AT24C256C is internally organized as 512 pages of 64 bytes each.

### 6.1 Device Addressing

Accessing the device requires an 8-bit device address byte following a Start condition to enable the device for a read or write operation. Since multiple client devices can reside on the serial bus, each client device must have its own unique address so the host can access each device independently.

The Most Significant four bits of the device address byte is referred to as the device type identifier. The device type identifier '1010' (Ah) is required in bits 7 through 4 of the device address byte (see [Table 6-1](#)).

Following the 4-bit device type identifier are the hardware client address bits, A2, A1 and A0. These bits can be used to expand the address space by allowing up to eight Serial EEPROM devices on the same bus. These hardware client address bits must correlate with the voltage level on the corresponding hardwired device address input pins A0, A1 and A2. The A0, A1 and A2 pins use an internal proprietary circuit that automatically biases the pin to a logic '0' state if the pin is allowed to float. In order to operate in a wide variety of application environments, the pull-down mechanism is intentionally designed to be somewhat strong. Once the pin is biased above the CMOS input buffer's trip point ( $\sim 0.5 \times V_{CC}$ ), the pull-down mechanism disengages. Microchip recommends connecting the A0, A1 and A2 pins to a known state whenever possible.

The eighth bit (bit 0) of the device address byte is the Read/Write Select bit. A read operation is initiated if this bit is high and a write operation is initiated if this bit is low.

Upon the successful comparison of the device address byte, the AT24C256C will return an ACK. If a valid comparison is not made, the device will NACK.

**Table 6-1. Device Addressing**

Package	Device Type Identifier				Hardware Client Address Bits			R/W Select
	Bit 7	Bit 6	Bit 5	Bit 4	Bit 3	Bit 2	Bit 1	Bit 0
SOIC, TSSOP, UDFN, VFBGA	1	0	1	0	A2	A1	A0	R/W

For all operations except the current address read, two 8-bit word address bytes must be transmitted to the device immediately following the device address byte. The word address bytes consist of the 15-bit memory array word address, and are used to specify which byte location in the EEPROM to start reading or writing.

The first word address byte contains the seven Most Significant bits of the word address (A14 through A8) in bit positions six through zero, as seen in [Table 6-2](#). Bit 7 of the first word address byte is a "don't care" bit as it is outside of the addressable 256-Kbit range. Upon completion of the first word address byte, the AT24C256C will return an ACK.

**Table 6-2. First Word Address Byte**

Bit 7	Bit 6	Bit 5	Bit 4	Bit 3	Bit 2	Bit 1	Bit 0
X	A14	A13	A12	A11	A10	A9	A8

Next, the second word address byte is sent to the device which provides the remaining eight bits of the word address (A7 through A0). Upon completion of the second word address byte, the AT24C256C will return an ACK. See [Table 6-3](#) to review these bit positions.

**Table 6-3. Second Word Address Byte**

Bit 7	Bit 6	Bit 5	Bit 4	Bit 3	Bit 2	Bit 1	Bit 0
A7	A6	A5	A4	A3	A2	A1	A0

## 7. Write Operations

All write operations for the AT24C256C begin with the host sending a Start condition, followed by a device address byte with the  $\overline{R\overline{W}}$  bit set to logic '0', and then by the word address bytes. The data value(s) to be written to the device immediately follow the word address bytes.

### 7.1 Byte Write

The AT24C256C supports the writing of a single 8-bit byte. Selecting a data word in the AT24C256C requires 15-bit word address.

Upon receipt of the proper device address and the word address bytes, the EEPROM will send an Acknowledge. The device will then be ready to receive the 8-bit data word. Following receipt of the 8-bit data word, the EEPROM will respond with an ACK. The addressing device, such as a bus host, must then terminate the write operation with a Stop condition. At that time, the EEPROM will enter an internally self-timed write cycle, which will be completed within  $t_{WR}$ , while the data word is being programmed into the nonvolatile EEPROM. All inputs are disabled during this write cycle and the EEPROM will not respond until the write is complete.

**Figure 7-1. Byte Write**

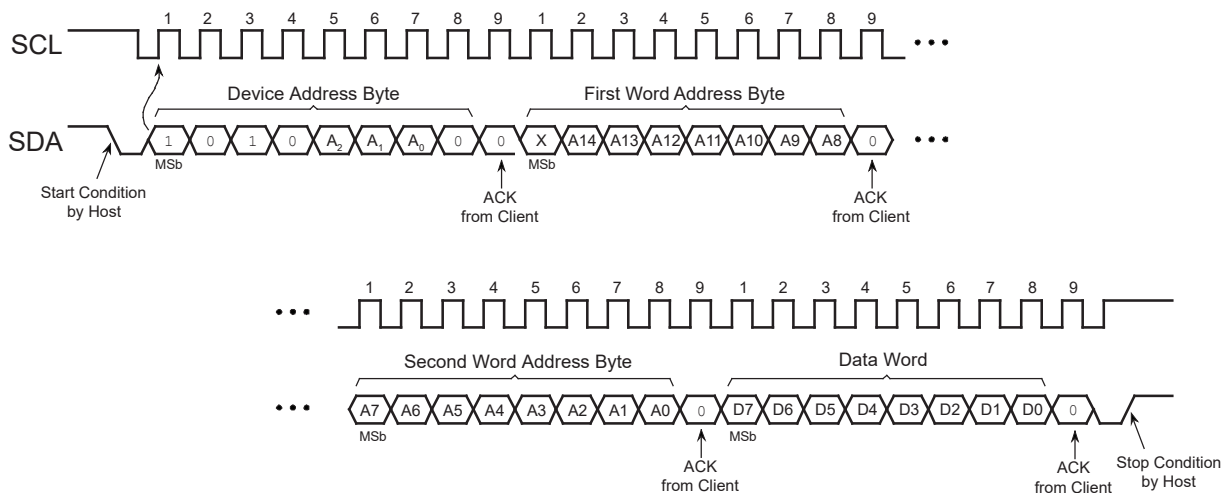

### 7.2 Page Write

A page write operation allows up to 64 bytes to be written in the same write cycle, provided all bytes are in the same row of the memory array (where address bits A<sub>14</sub> through A<sub>6</sub> are the same). Partial page writes of less than 64 bytes are also allowed.

A page write is initiated the same way as a byte write, but the bus host does not send a Stop condition after the first data word is clocked in. Instead, after the EEPROM acknowledges receipt of the first data word, the bus host can transmit up to sixty three additional data words. The EEPROM will respond with an ACK after each data word is received. Once all data to be written has been sent to the device, the bus host must issue a Stop condition (see [Figure 7-2](#)) at which time the internally self-timed write cycle will begin.

The lower six bits of the word address are internally incremented following the receipt of each data word. The higher order address bits are not incremented and retain the memory page row location. Page write operations are limited to writing bytes within a single physical page, regardless of the number of bytes actually being written. When the incremented word address reaches the page boundary, the address counter will rollover to the beginning of the same page. Nevertheless, creating a rollover event should be avoided as previously loaded data in the page could become unintentionally altered.

**Figure 7-2. Page Write**

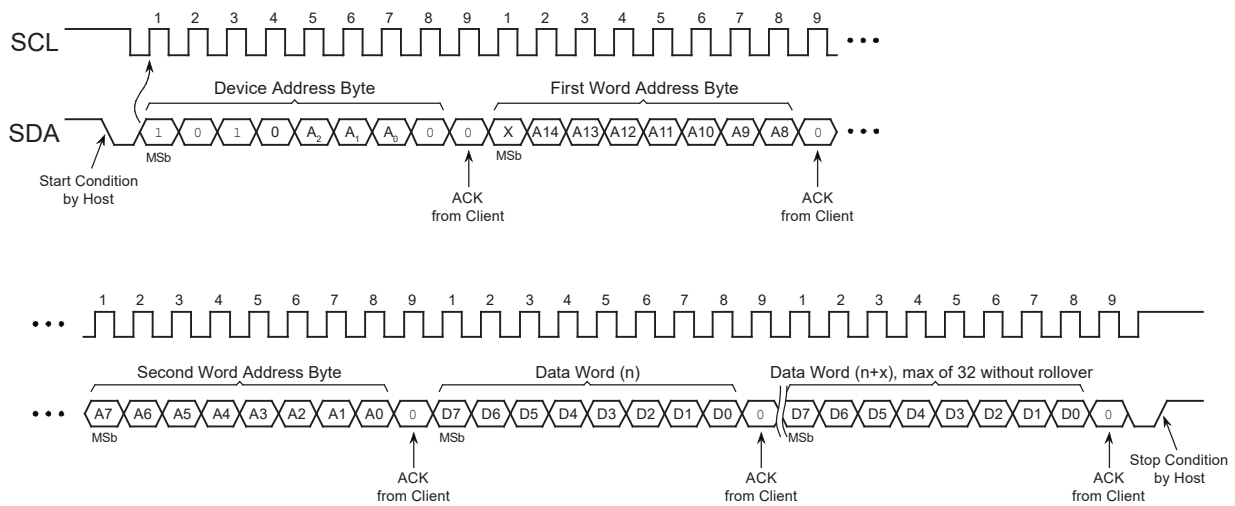

### 7.3 Acknowledge Polling

An Acknowledge Polling routine can be implemented to optimize time-sensitive applications that would prefer not to wait the fixed maximum write cycle time ( $t_{WR}$ ). This method allows the application to know immediately when the Serial EEPROM write cycle has completed, so a subsequent operation can be started.

Once the internally self-timed write cycle has started, an Acknowledge Polling routine can be initiated. This involves repeatedly sending a Start condition followed by a valid device address byte with the  $R/\bar{W}$  bit set at logic '0'. The device will not respond with an ACK while the write cycle is ongoing. Once the internal write cycle has completed, the EEPROM will respond with an ACK, allowing a new read or write operation to be immediately initiated. A flowchart has been included below in [Figure 7-3](#) to better illustrate this technique.

**Figure 7-3. Acknowledge Polling Flowchart**

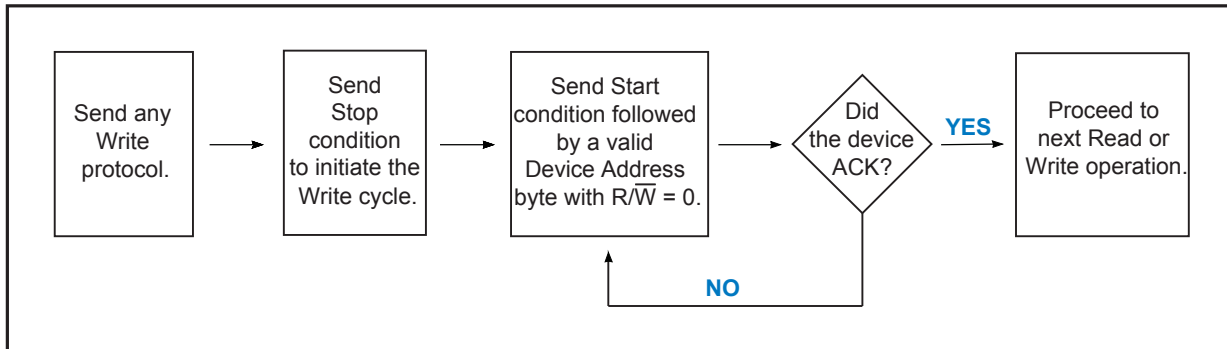

### 7.4 Write Cycle Timing

The length of the self-timed write cycle ( $t_{WR}$ ) is defined as the amount of time from the Stop condition that begins the internal write cycle to the Start condition of the first device address byte sent to the AT24C256C that it subsequently responds to with an ACK. [Figure 7-4](#) has been included to show this measurement. During the internally self-timed write cycle, any attempts to read from or write to the memory array will not be processed.

**Figure 7-4. Write Cycle Timing**

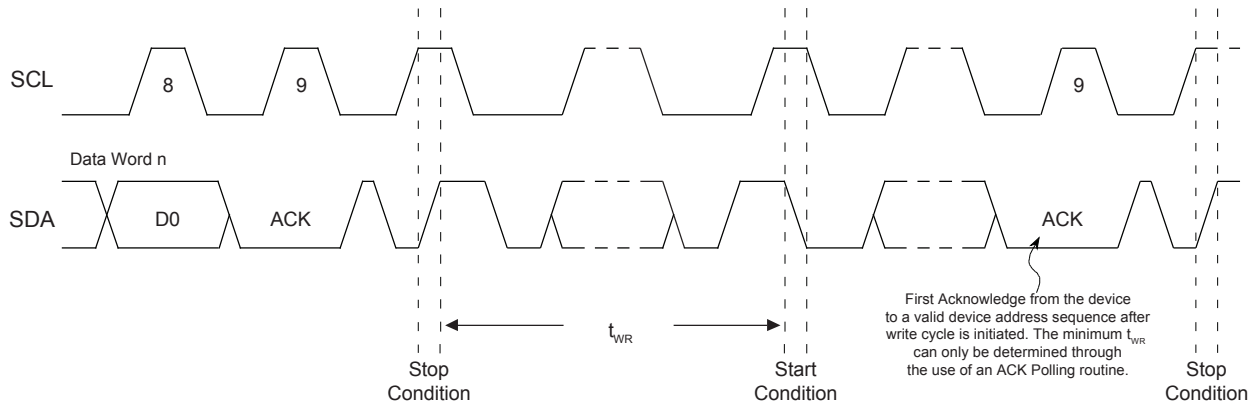

## 7.5 Write Protection

The AT24C256C utilizes a hardware data protection scheme that allows the user to write-protect the entire memory array contents when the WP pin is at  $V_{CC}$  (or a valid  $V_{IH}$ ). No write protection will be set if the WP pin is at GND or left floating.

**Table 7-1. Write-Protect Behavior**

WP Pin Voltage	Part of the Array Protected
$V_{CC}$	Full Array
GND	None — Write Protection Not Enabled

The status of the WP pin is sampled at the Stop condition for every byte write or page write operation prior to the start of an internally self-timed write cycle. Changing the WP pin state after the Stop condition has been sent will not alter or interrupt the execution of the write cycle.

If an attempt is made to write to the device while the WP pin has been asserted, the device will acknowledge the device address, word address and data bytes. However, no write cycle will occur when the Stop condition is issued. The device will immediately be ready to accept a new read or write operation.

## 8. Read Operations

Read operations are initiated the same way as write operations with the exception that the Read/Write Select bit in the device address byte must be a logic '1'. There are three read operations:

- Current Address Read
- Random Address Read
- Sequential Read

### 8.1 Current Address Read

The internal data word address counter maintains the last address accessed during the last read or write operation, incremented by one. This address stays valid between operations as long as the  $V_{CC}$  is maintained to the part. The address rollover during a read is from the last byte of the last page to the first byte of the first page of the memory.

A current address read operation will output data according to the location of the internal data word address counter. This is initiated with a Start condition, followed by a valid device address byte with the  $R\bar{W}$  bit set to logic '1'. The device will ACK this sequence and the current address data word is serially clocked out on the SDA line. All types of read operations will be terminated if the bus host does not respond with an ACK (it NACKs) during the ninth clock cycle. After the NACK response, the host may send a Stop condition to complete the protocol or it can send a Start condition to begin the next sequence.

**Figure 8-1. Current Address Read**

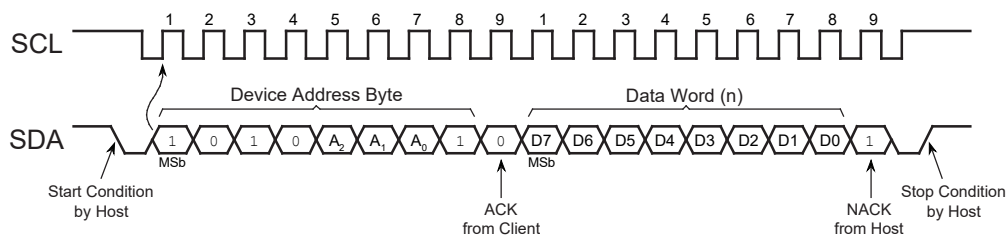

### 8.2 Random Read

A random read begins in the same way as a byte write operation does to load in a new data word address. This is known as a "dummy write" sequence; however, the data byte and the Stop condition of the byte write must be omitted to prevent the part from entering an internal write cycle. Once the device address and word address are clocked in and acknowledged by the EEPROM, the bus host must generate another Start condition. The bus host now initiates a current address read by sending a Start condition, followed by a valid device address byte with the  $R\bar{W}$  bit set to logic '1'. The EEPROM will ACK the device address and serially clock out the data word on the SDA line. All types of read operations will be terminated if the bus host does not respond with an ACK (it NACKs) during the ninth clock cycle. After the NACK response, the host may send a Stop condition to complete the protocol, or it can send a Start condition to begin the next sequence.

**Figure 8-2. Random Read**

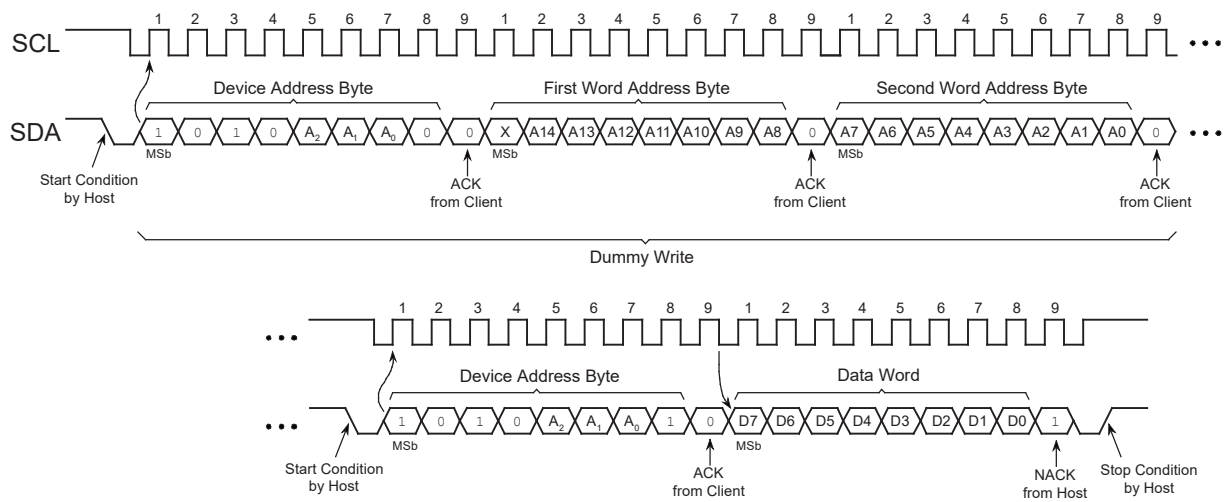

### 8.3 Sequential Read

Sequential reads are initiated by either a current address read or a random read. After the bus host receives a data word, it responds with an Acknowledge. As long as the EEPROM receives an ACK, it will continue to increment the word address and serially clock out sequential data words. When the maximum memory address is reached, the data word address will rollover and the sequential read will continue from the beginning of the memory array. All types of read operations will be terminated if the bus host does not respond with an ACK (it NACKs) during the ninth clock cycle. After the NACK response, the host may send a Stop condition to complete the protocol or it can send a Start condition to begin the next sequence.

**Figure 8-3. Sequential Read**

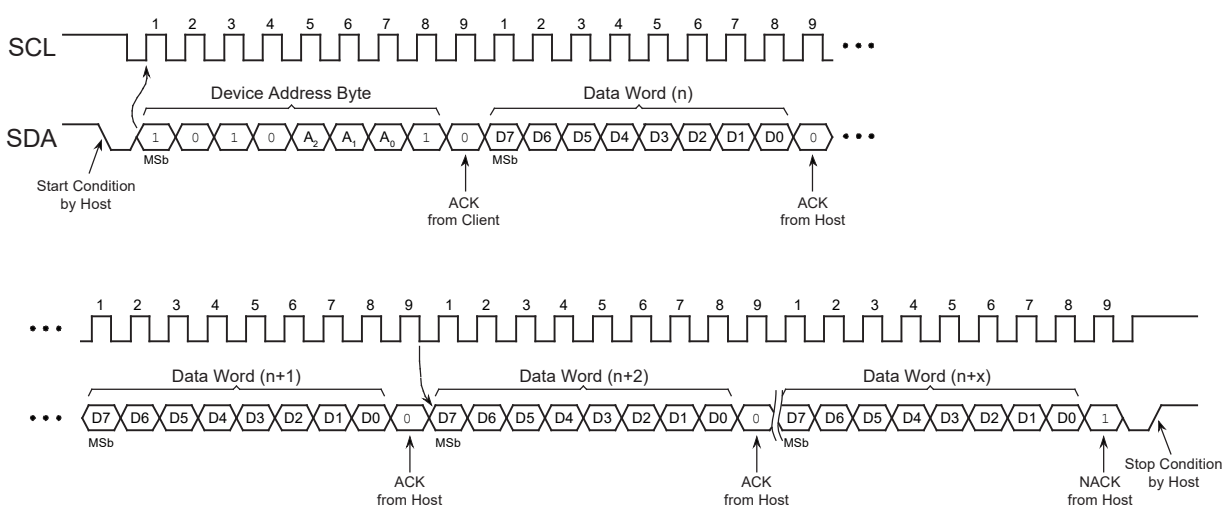

**9. Device Default Condition from Microchip**

The AT24C256C is delivered with the EEPROM array set to logic '1', resulting in FFh data in all locations.







## 10. Packaging Information

### 10.1 Package Marking Information

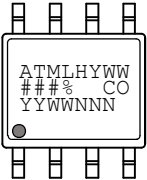
Figure 10-1. Package Marking Information

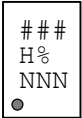
### AT24C256C: Package Marking Information

8-lead SOIC	8-lead TSSOP
	
8-pad UDFN	8-ball VFBGA
2.0 x 3.0 mm Body	2.35 x 3.73 mm Body
	

Note 1: ● designates pin 1  
Note 2: Package drawings are not to scale

Catalog Number Truncation			
AT24C256C		Truncation Code ###: 2EC	
Date Codes			Voltages
YY = Year	Y = Year	WW = Work Week of Assembly	% = Minimum Voltage
16: 2016    20: 2020	6: 2016    0: 2020	02: Week 2	L: 1.7V min
17: 2017    21: 2021	7: 2017    1: 2021	04: Week 4	
18: 2018    22: 2022	8: 2018    2: 2022	...	
19: 2019    23: 2023	9: 2019    3: 2023	52: Week 52	
Country of Origin		Device Grade	Atmel Truncation
CO = Country of Origin		H or U: Industrial Grade	AT: Atmel ATM: Atmel ATML: Atmel
Lot Number or Trace Code			
NNN = Alphanumeric Trace Code (2 Characters for Small Packages)			

**8-Lead Plastic Small Outline (SN) - Narrow, 3.90 mm (.150 In.) Body [SOIC]**

**Note:** For the most current package drawings, please see the Microchip Packaging Specification located at <http://www.microchip.com/packaging>

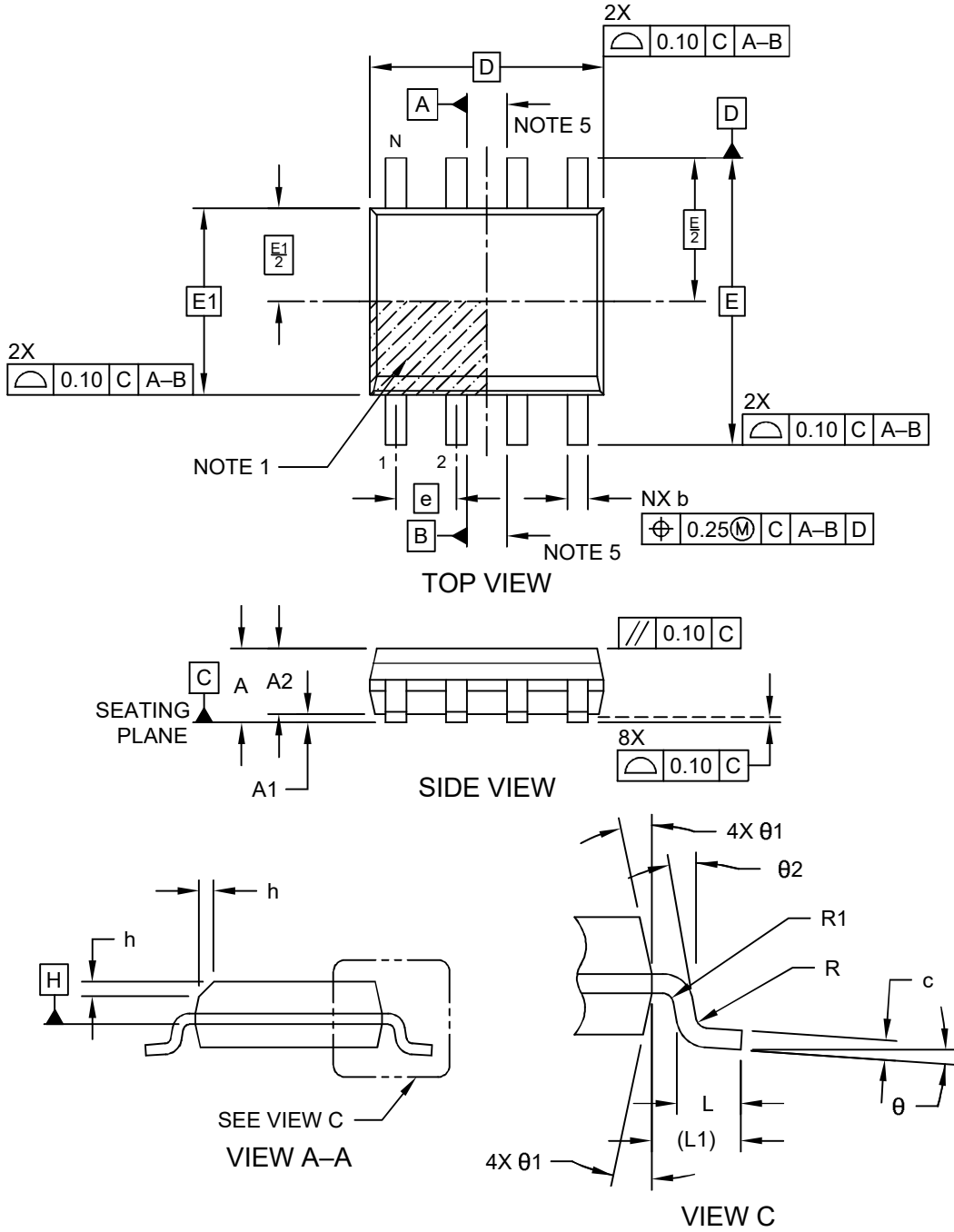

Microchip Technology Drawing No. C04-057-SN Rev H Sheet 1 of 2

### 8-Lead Plastic Small Outline (SN) - Narrow, 3.90 mm (.150 In.) Body [SOIC]

**Note:** For the most current package drawings, please see the Microchip Packaging Specification located at <http://www.microchip.com/packaging>

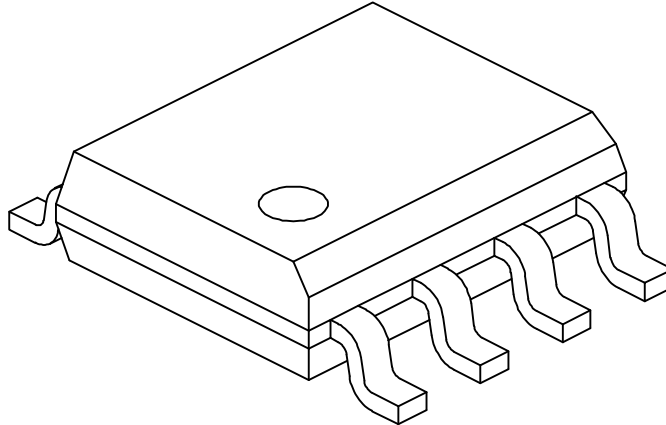

Dimension Limits	Units	MILLIMETERS		
		MIN	NOM	MAX
Number of Pins	N	8		
Pitch	e	1.27 BSC		
Overall Height	A	–	–	1.75
Molded Package Thickness	A2	1.25	–	–
Standoff §	A1	0.10	–	0.25
Overall Width	E	6.00 BSC		
Molded Package Width	E1	3.90 BSC		
Overall Length	D	4.90 BSC		
Chamfer (Optional)	h	0.25	–	0.50
Foot Length	L	0.40	–	1.27
Footprint	L1	1.04 REF		
Lead Thickness	c	0.17	–	0.25
Lead Width	b	0.31	–	0.51
Lead Bend Radius	R	0.07	–	–
Lead Bend Radius	R1	0.07	–	–
Foot Angle	θ	0°	–	8°
Mold Draft Angle	θ1	5°	–	15°
Lead Angle	θ2	0°	–	8°

**Notes:**

1. Pin 1 visual index feature may vary, but must be located within the hatched area.
2. § Significant Characteristic
3. Dimensions D and E1 do not include mold flash or protrusions. Mold flash or protrusions shall not exceed 0.15mm per side.
4. Dimensioning and tolerancing per ASME Y14.5M
  - BSC: Basic Dimension. Theoretically exact value shown without tolerances.
  - REF: Reference Dimension, usually without tolerance, for information purposes only.
5. Datums A & B to be determined at Datum H.

Microchip Technology Drawing No. C04-057-SN Rev H Sheet 2 of 2

### 8-Lead Plastic Small Outline (SN) - Narrow, 3.90 mm (.150 In.) Body [SOIC]

**Note:** For the most current package drawings, please see the Microchip Packaging Specification located at <http://www.microchip.com/packaging>

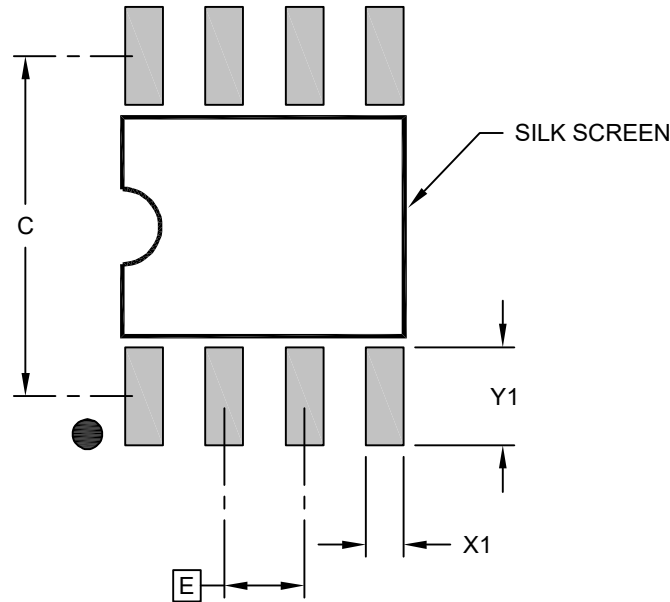

**RECOMMENDED LAND PATTERN**

		MILLIMETERS		
		MIN	NOM	MAX
	Units			
	Dimension Limits			
Contact Pitch	E	1.27 BSC		
Contact Pad Spacing	C	5.40		
Contact Pad Width (X8)	X1			0.60
Contact Pad Length (X8)	Y1			1.55

**Notes:**

1. Dimensioning and tolerancing per ASME Y14.5M  
 BSC: Basic Dimension. Theoretically exact value shown without tolerances.

Microchip Technology Drawing C04-2057-SN Rev H

**8-Lead Plastic Thin Shrink Small Outline (ST) - 4.4 mm Body [TSSOP]**

**Note:** For the most current package drawings, please see the Microchip Packaging Specification located at <http://www.microchip.com/packaging>

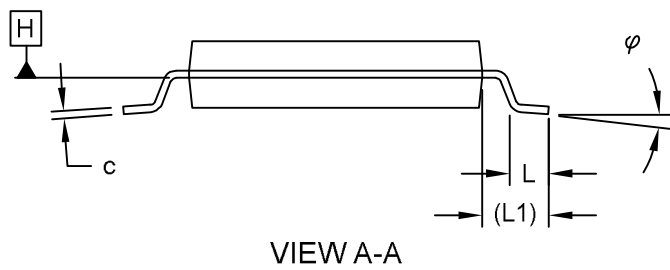
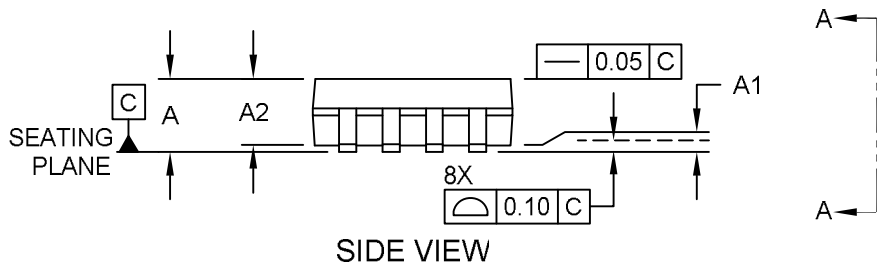
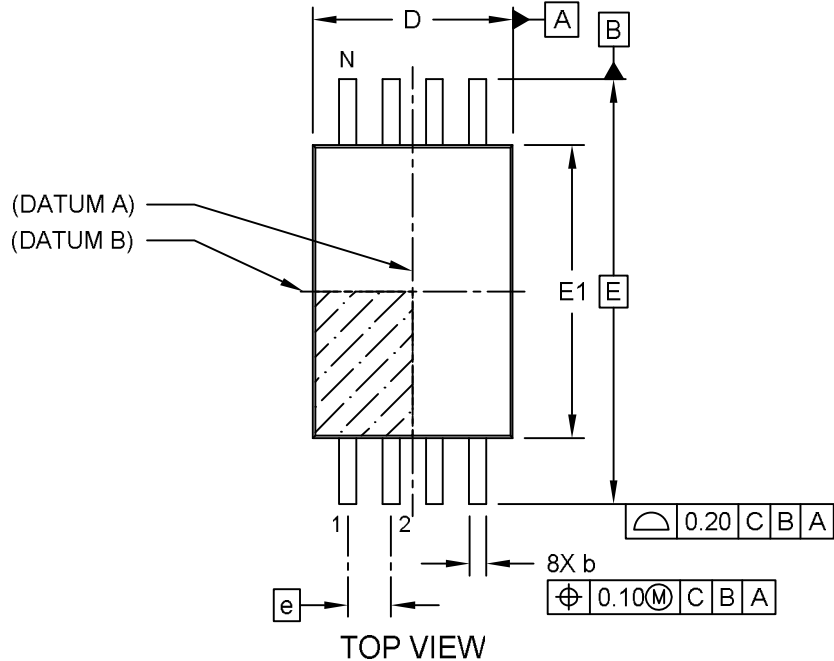

Microchip Technology Drawing C04-086 Rev C Sheet 1 of 2

### 8-Lead Plastic Thin Shrink Small Outline (ST) - 4.4 mm Body [TSSOP]

**Note:** For the most current package drawings, please see the Microchip Packaging Specification located at <http://www.microchip.com/packaging>

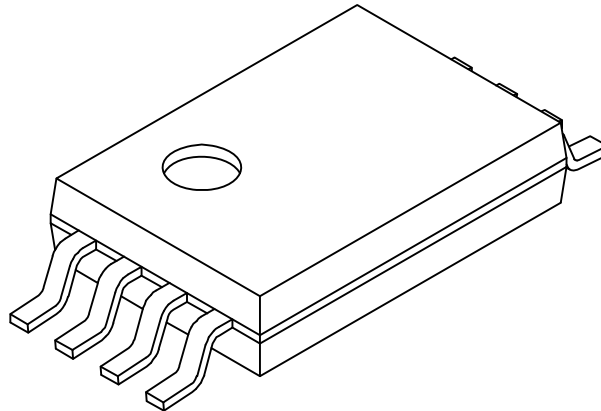

		Units	MILLIMETERS		
Dimension Limits			MIN	NOM	MAX
Number of Pins	N		8		
Pitch	e		0.65 BSC		
Overall Height	A	-	-	-	1.20
Molded Package Thickness	A2	0.80	1.00		1.05
Standoff	A1	0.05	-	-	-
Overall Width	E		6.40 BSC		
Molded Package Width	E1	4.30	4.40		4.50
Overall Length	D	2.90	3.00		3.10
Foot Length	L	0.45	0.60		0.75
Footprint	L1		1.00 REF		
Lead Thickness	c	0.09	-		0.25
Foot Angle	$\varphi$	0°	4°		8°
Lead Width	b	0.19	-		0.30

**Notes:**

1. Pin 1 visual index feature may vary, but must be located within the hatched area.
2. Dimensions D and E1 do not include mold flash or protrusions. Mold flash or protrusions shall not exceed 0.20mm per side.
3. Dimensioning and tolerancing per ASME Y14.5M
  - BSC: Basic Dimension. Theoretically exact value shown without tolerances.
  - REF: Reference Dimension, usually without tolerance, for information purposes only.

Microchip Technology Drawing C04-086 Rev C Sheet 2 of 2

### 8-Lead Plastic Thin Shrink Small Outline (ST) - 4.4 mm Body [TSSOP]

**Note:** For the most current package drawings, please see the Microchip Packaging Specification located at <http://www.microchip.com/packaging>

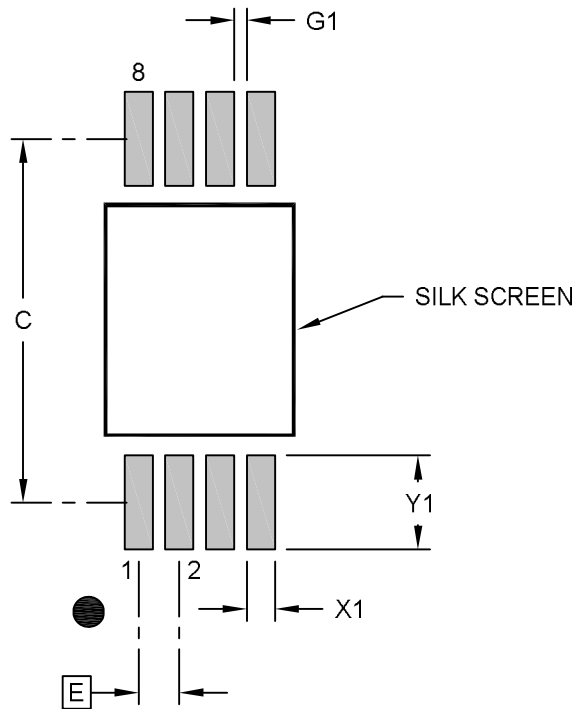

**RECOMMENDED LAND PATTERN**

Units		MILLIMETERS		
Dimension Limits		MIN	NOM	MAX
Contact Pitch	E	0.65 BSC		
Contact Pad Spacing	C		5.80	
Contact Pad Width (X8)	X1			0.45
Contact Pad Length (X8)	Y1			1.50
Contact Pad to Center Pad (X6)	G1	0.20		

**Notes:**

1. Dimensioning and tolerancing per ASME Y14.5M  
     BSC: Basic Dimension. Theoretically exact value shown without tolerances.
2. For best soldering results, thermal vias, if used, should be filled or tented to avoid solder loss during reflow process

Microchip Technology Drawing C04-2086 Rev B

### 8-Lead Ultra Thin Plastic Dual Flat, No Lead Package (Q4B) - 2x3 mm Body [UDFN] Atmel Legacy Global Package Code YNZ

**Note:** For the most current package drawings, please see the Microchip Packaging Specification located at <http://www.microchip.com/packaging>

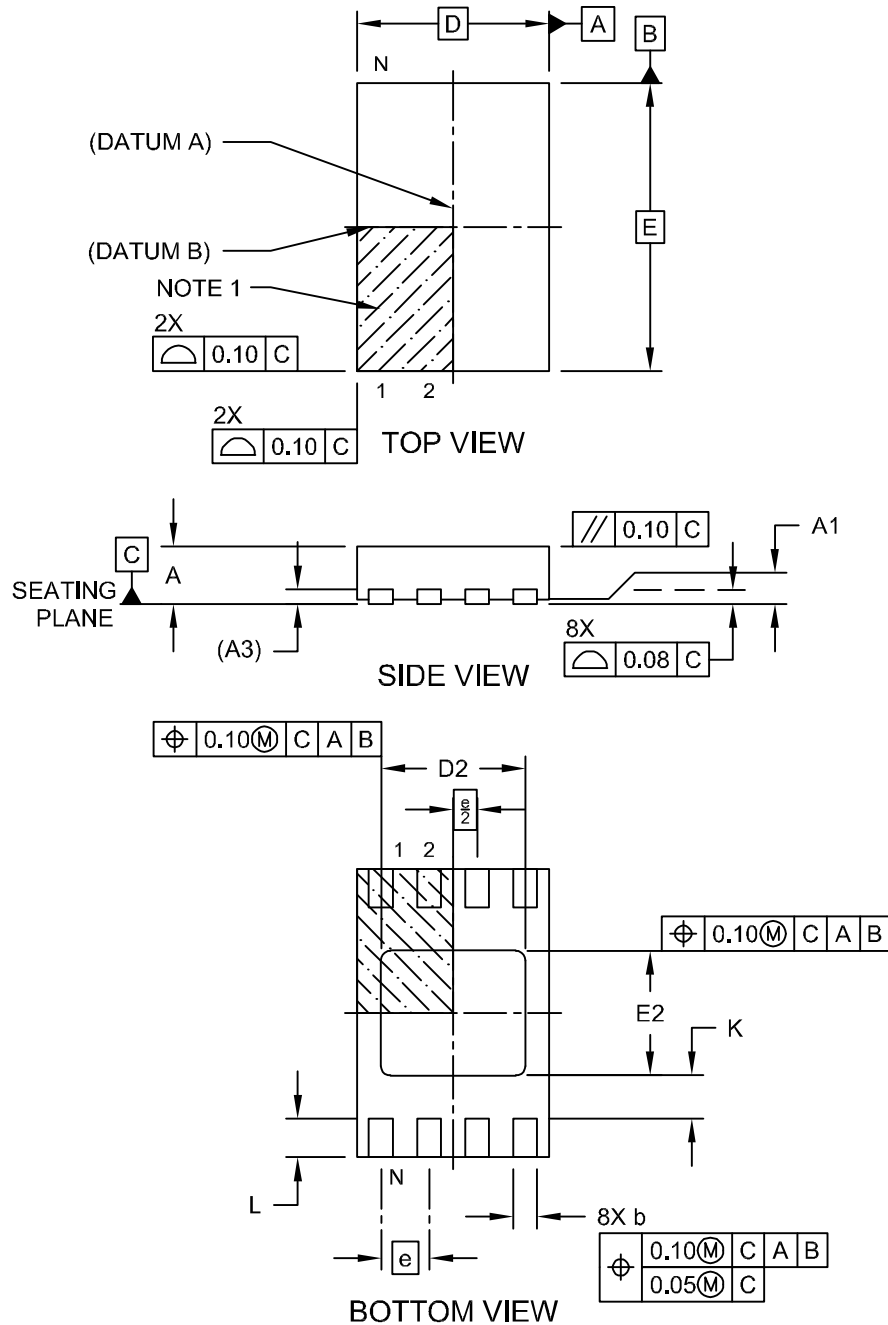

Microchip Technology Drawing C04-21355-Q4B Rev C Sheet 1 of 2



### 8-Lead Ultra Thin Plastic Dual Flat, No Lead Package (Q4B) - 2x3 mm Body [UDFN] Atmel Legacy Global Package Code YNZ

**Note:** For the most current package drawings, please see the Microchip Packaging Specification located at <http://www.microchip.com/packaging>

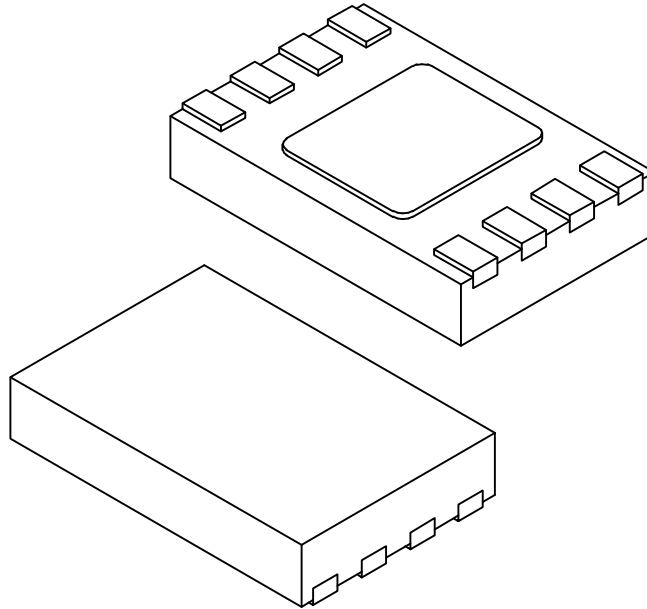

Dimension Limits	Units	MILLIMETERS		
		MIN	NOM	MAX
Number of Terminals	N	8		
Pitch	e	0,50 BSC		
Overall Height	A	0,50	0,55	0,60
Standoff	A1	0,00	0,02	0,05
Terminal Thickness	A3	0,152 REF		
Overall Length	D	2,00 BSC		
Exposed Pad Length	D2	1,40	1,50	1,60
Overall Width	E	3,00 BSC		
Exposed Pad Width	E2	1,20	1,30	1,40
Terminal Width	b	0,18	0,25	0,30
Terminal Length	L	0,25	0,35	0,45
Terminal-to-Exposed-Pad	K	0,20	-	-

**Notes:**

1. Pin 1 visual index feature may vary, but must be located within the hatched area.
2. Package is saw singulated
3. Dimensioning and tolerancing per ASME Y14.5M

BSC: Basic Dimension. Theoretically exact value shown without tolerances.

REF: Reference Dimension, usually without tolerance, for information purposes only.

Microchip Technology Drawing C04-21355-Q4B Rev C Sheet 2 of 2

### 8-Lead Ultra Thin Plastic Dual Flat, No Lead Package (Q4B) - 2x3 mm Body [UDFN] Atmel Legacy Global Package Code YNZ

**Note:** For the most current package drawings, please see the Microchip Packaging Specification located at <http://www.microchip.com/packaging>

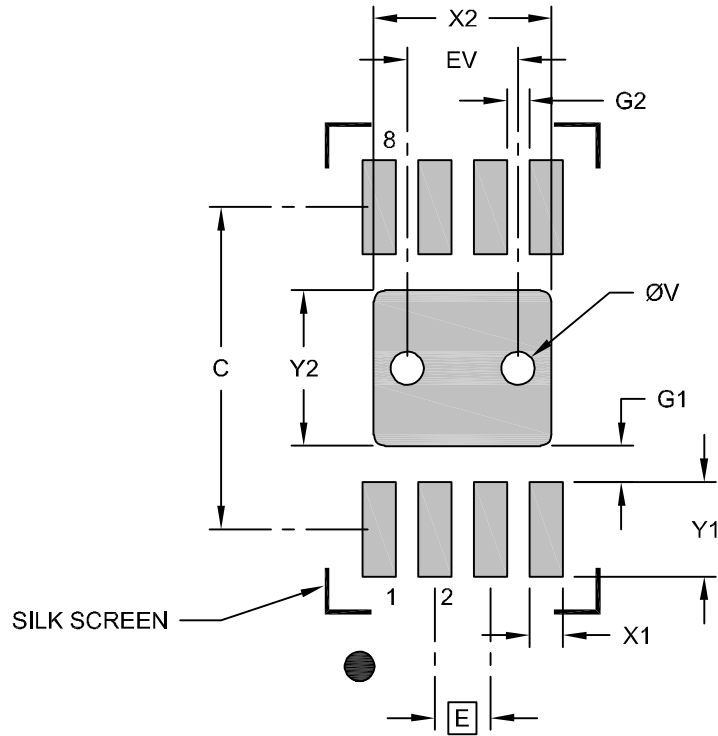

**RECOMMENDED LAND PATTERN**

		Units	MILLIMETERS		
Dimension Limits			MIN	NOM	MAX
Contact Pitch	E		0,50 BSC		
Optional Center Pad Width	X2				1,60
Optional Center Pad Length	Y2				1,40
Contact Pad Spacing	C			2,90	
Contact Pad Width (X8)	X1				0,30
Contact Pad Length (X8)	Y1				0,85
Contact Pad to Center Pad (X8)	G1		0,33		
Contact Pad to Contact Pad (X6)	G2		0,20		
Thermal Via Diameter	V			0,30	
Thermal Via Pitch	EV			1,00	

**Notes:**

1. Dimensioning and tolerancing per ASME Y14,5M  
BSC: Basic Dimension. Theoretically exact value shown without tolerances.
2. For best soldering results, thermal vias, if used, should be filled or tented to avoid solder loss during reflow process

Microchip Technology Drawing C04-23355-Q4B Rev C

# AT24C256C

## Packaging Information

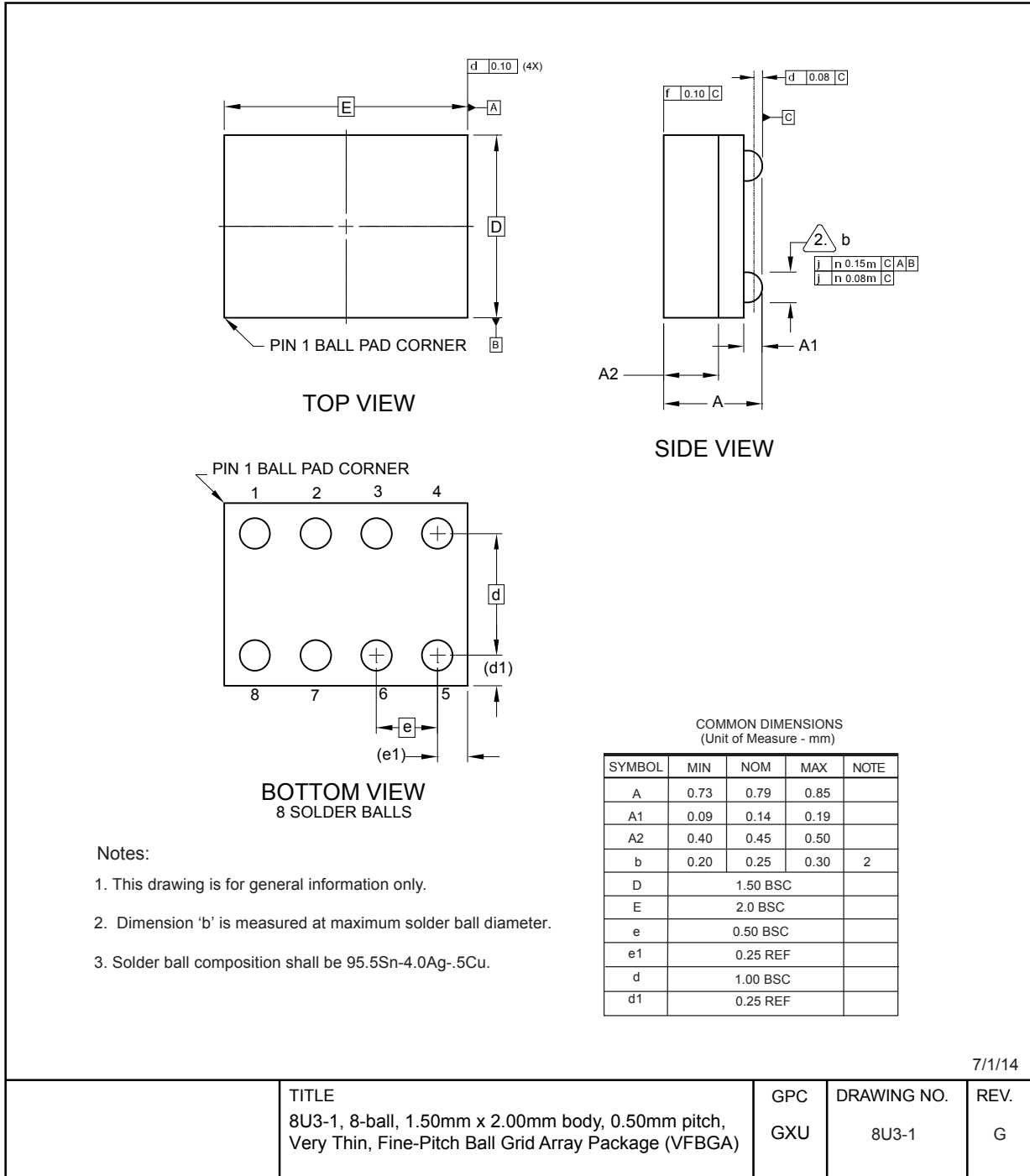

7/1/14

	TITLE 8U3-1, 8-ball, 1.50mm x 2.00mm body, 0.50mm pitch, Very Thin, Fine-Pitch Ball Grid Array Package (VFBGA)	GPC GXU	DRAWING NO. 8U3-1	REV. G
--	--	------------	----------------------	-----------

**Note:** For the most current package drawings, please see the Microchip Packaging Specification located at <http://www.microchip.com/packaging>.

## **11. Revision History**

### **Revision B (June 2022)**

Updated section content throughout for clarification. Added note to Table 4-6 that explains the array architecture and how endurance is specified. Updated Part Marking Information. Updated the SOIC, TSSOP and UDFN package drawings. Updated “master” and “slave” terminology with “host” and “client” respectively.

### **Revision A (August 2018)**

Updated to the Microchip template. Microchip DS20006042 replaces Atmel document 8568. Corrected  $t_{LOW}$  typo from 400 ns to 500 ns. Corrected  $t_{AA}$  typo from 550 ns to 450 ns. Updated Part Marking Information. Updated the “Software Reset” section. Added ESD rating. Removed lead finish designation. Updated trace code format in package markings. Updated section content throughout for clarification. Added a figure for “System Configuration Using 2-Wire Serial EEPROMs”. Added POR recommendations section. Updated the SOIC, TSSOP and UDFN package drawings to Microchip format.

### **Atmel Document 8568 Revision F (January 2015)**

Add the UDFN Expanded Quantity Option. Update 8X, 8MA2, and 8U2-1 package outline drawings, the ordering information section, and the disclaimer page.

### **Atmel Document 8568 Revision E (August 2012)**

Update template and Atmel logo. Correct 8-lead UDFN to 8-pad UDFN. Update AC characteristics from  $\mu$ s to ns units and their respective values. Update part marking description.

### **Atmel Document 8568 Revision D (September 2011)**

Atmel global device marking alignment. Update 8S1, 8A2 to 8X, 8MA2, and 8U2-1 package drawings.

### **Atmel Document 8568 Revision C (May 2010)**

Update 8S1 and 8A2 package drawings.

### **Atmel Document 8568 Revision B (March 2010)**

Part Markings and ordering detail/codes updated.

### **Atmel Document 8568 Revision A (September 2009)**

Initial document release.

---

## The Microchip Website

---

Microchip provides online support via our website at [www.microchip.com/](http://www.microchip.com/). This website is used to make files and information easily available to customers. Some of the content available includes:

- **Product Support** – Data sheets and errata, application notes and sample programs, design resources, user's guides and hardware support documents, latest software releases and archived software
- **General Technical Support** – Frequently Asked Questions (FAQs), technical support requests, online discussion groups, Microchip design partner program member listing
- **Business of Microchip** – Product selector and ordering guides, latest Microchip press releases, listing of seminars and events, listings of Microchip sales offices, distributors and factory representatives

---

## Product Change Notification Service

---

Microchip's product change notification service helps keep customers current on Microchip products. Subscribers will receive email notification whenever there are changes, updates, revisions or errata related to a specified product family or development tool of interest.

To register, go to [www.microchip.com/pcn](http://www.microchip.com/pcn) and follow the registration instructions.

---

## Customer Support

---

Users of Microchip products can receive assistance through several channels:

- Distributor or Representative
- Local Sales Office
- Embedded Solutions Engineer (ESE)
- Technical Support

Customers should contact their distributor, representative or ESE for support. Local sales offices are also available to help customers. A listing of sales offices and locations is included in this document.

Technical support is available through the website at: [www.microchip.com/support](http://www.microchip.com/support)

## Product Identification System

To order or obtain information, e.g., on pricing or delivery, refer to the factory or the listed sales office.

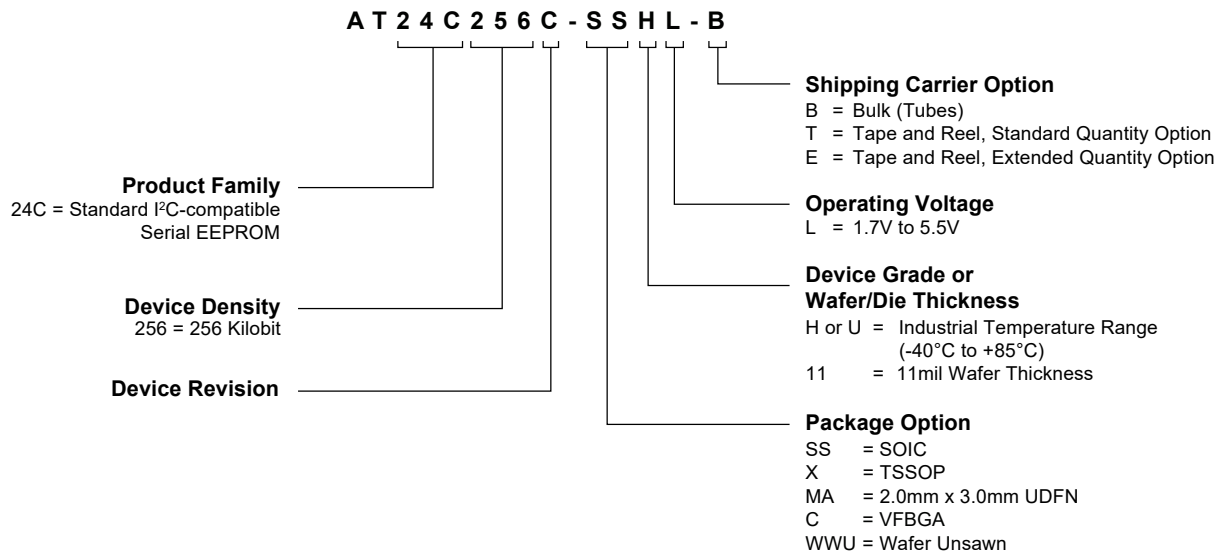

**Note:** Refer to automotive data sheet for automotive grade ordering information.

### Examples

Device	Package	Package Drawing Code	Package Option	Shipping Carrier Option	Device Grade
AT24C256C-SSHL-B	SOIC	SN	SS	Bulk (Tubes)	Industrial Temperature (-40°C to 85°C)
AT24C256C-SSHL-T	SOIC	SN	SS	Tape and Reel	
AT24C256C-XHL-T	TSSOP	ST	X	Tape and Reel	
AT24C256C-MAHL-T	UDFN	Q4B	MA	Tape and Reel	
AT24C256C-MAHL-E	UDFN	Q4B	MA	Extended Qty. Tape and Reel	
AT24C256C-CUL-T	VFBGA	8U2-1	C	Tape and Reel	

## Microchip Devices Code Protection Feature

Note the following details of the code protection feature on Microchip products:

- Microchip products meet the specifications contained in their particular Microchip Data Sheet.
- Microchip believes that its family of products is secure when used in the intended manner, within operating specifications, and under normal conditions.
- Microchip values and aggressively protects its intellectual property rights. Attempts to breach the code protection features of Microchip product is strictly prohibited and may violate the Digital Millennium Copyright Act.
- Neither Microchip nor any other semiconductor manufacturer can guarantee the security of its code. Code protection does not mean that we are guaranteeing the product is “unbreakable”. Code protection is constantly evolving. Microchip is committed to continuously improving the code protection features of our products.

## Legal Notice

This publication and the information herein may be used only with Microchip products, including to design, test, and integrate Microchip products with your application. Use of this information in any other manner violates these terms. Information regarding device applications is provided only for your convenience and may be superseded by updates. It is your responsibility to ensure that your application meets with your specifications. Contact your local Microchip sales office for additional support or, obtain additional support at [www.microchip.com/en-us/support/design-help/client-support-services](http://www.microchip.com/en-us/support/design-help/client-support-services).

THIS INFORMATION IS PROVIDED BY MICROCHIP "AS IS". MICROCHIP MAKES NO REPRESENTATIONS OR WARRANTIES OF ANY KIND WHETHER EXPRESS OR IMPLIED, WRITTEN OR ORAL, STATUTORY OR OTHERWISE, RELATED TO THE INFORMATION INCLUDING BUT NOT LIMITED TO ANY IMPLIED WARRANTIES OF NON-INFRINGEMENT, MERCHANTABILITY, AND FITNESS FOR A PARTICULAR PURPOSE, OR WARRANTIES RELATED TO ITS CONDITION, QUALITY, OR PERFORMANCE.

IN NO EVENT WILL MICROCHIP BE LIABLE FOR ANY INDIRECT, SPECIAL, PUNITIVE, INCIDENTAL, OR CONSEQUENTIAL LOSS, DAMAGE, COST, OR EXPENSE OF ANY KIND WHATSOEVER RELATED TO THE INFORMATION OR ITS USE, HOWEVER CAUSED, EVEN IF MICROCHIP HAS BEEN ADVISED OF THE POSSIBILITY OR THE DAMAGES ARE FORESEEABLE. TO THE FULLEST EXTENT ALLOWED BY LAW, MICROCHIP'S TOTAL LIABILITY ON ALL CLAIMS IN ANY WAY RELATED TO THE INFORMATION OR ITS USE WILL NOT EXCEED THE AMOUNT OF FEES, IF ANY, THAT YOU HAVE PAID DIRECTLY TO MICROCHIP FOR THE INFORMATION.

Use of Microchip devices in life support and/or safety applications is entirely at the buyer's risk, and the buyer agrees to defend, indemnify and hold harmless Microchip from any and all damages, claims, suits, or expenses resulting from such use. No licenses are conveyed, implicitly or otherwise, under any Microchip intellectual property rights unless otherwise stated.

## Trademarks

The Microchip name and logo, the Microchip logo, Adaptec, AnyRate, AVR, AVR logo, AVR Freaks, BesTime, BitCloud, CryptoMemory, CryptoRF, dsPIC, flexPWR, HELDO, IGLOO, JukeBlox, KeeLoq, Klear, LANCheck, LinkMD, maXStylus, maXTouch, MediaLB, megaAVR, Microsemi, Microsemi logo, MOST, MOST logo, MPLAB, OptoLyzer, PIC, picoPower, PICSTART, PIC32 logo, PolarFire, Prochip Designer, QTouch, SAM-BA, SenGenuity, SpyNIC, SST, SST Logo, SuperFlash, Symmetricom, SyncServer, Tachyon, TimeSource, tinyAVR, UNI/O, Vectron, and XMEGA are registered trademarks of Microchip Technology Incorporated in the U.S.A. and other countries.

AgileSwitch, APT, ClockWorks, The Embedded Control Solutions Company, EtherSynch, Flashtec, Hyper Speed Control, HyperLight Load, IntelliMOS, Libero, motorBench, mTouch, Powermite 3, Precision Edge, ProASIC, ProASIC Plus, ProASIC Plus logo, Quiet-Wire, SmartFusion, SyncWorld, Temux, TimeCesium, TimeHub, TimePictra, TimeProvider, TrueTime, WinPath, and ZL are registered trademarks of Microchip Technology Incorporated in the U.S.A.

Adjacent Key Suppression, AKS, Analog-for-the-Digital Age, Any Capacitor, AnyIn, AnyOut, Augmented Switching, BlueSky, BodyCom, CodeGuard, CryptoAuthentication, CryptoAutomotive, CryptoCompanion, CryptoController, dsPICDEM, dsPICDEM.net, Dynamic Average Matching, DAM, ECAN, Espresso T1S, EtherGREEN, GridTime, IdealBridge, In-Circuit Serial Programming, ICSP, INICnet, Intelligent Paralleling, Inter-Chip Connectivity, JitterBlocker, Knob-on-Display, maxCrypto, maxView, memBrain, Mindi, MiWi, MPASM, MPF, MPLAB Certified logo, MPLIB, MPLINK, MultiTRAK, NetDetach, NVM Express, NVMe, Omniscient Code Generation, PICDEM, PICDEM.net, PICkit, PICtail, PowerSmart, PureSilicon, QMatrix, REAL ICE, Ripple Blocker, RTAX, RTG4, SAM-ICE, Serial Quad I/O, simpleMAP, SimpliPHY, SmartBuffer, SmartHLS, SMART-I.S., storClad, SQL, SuperSwitcher, SuperSwitcher II, Switchtec, SynchroPHY, Total Endurance, TSHARC, USBCheck, VariSense, VectorBlox, VeriPHY, ViewSpan, WiperLock, XpressConnect, and ZENA are trademarks of Microchip Technology Incorporated in the U.S.A. and other countries.

SQTP is a service mark of Microchip Technology Incorporated in the U.S.A.

The Adaptec logo, Frequency on Demand, Silicon Storage Technology, Symmcom, and Trusted Time are registered trademarks of Microchip Technology Inc. in other countries.

GestIC is a registered trademark of Microchip Technology Germany II GmbH & Co. KG, a subsidiary of Microchip Technology Inc., in other countries.

All other trademarks mentioned herein are property of their respective companies.

© 2018-2022, Microchip Technology Incorporated and its subsidiaries. All Rights Reserved.

ISBN: 978-6683-0446-4

AMBA, Arm, Arm7, Arm7TDMI, Arm9, Arm11, Artisan, big.LITTLE, Cordio, CoreLink, CoreSight, Cortex, DesignStart, DynamIQ, Jazelle, Keil, Mali, Mbed, Mbed Enabled, NEON, POP, RealView, SecurCore, Socrates, Thumb, TrustZone, ULINK, ULINK2, ULINK-ME, ULINK-PLUS, ULINKpro,  $\mu$ Vision, Versatile are trademarks or registered trademarks of Arm Limited (or its subsidiaries) in the US and/or elsewhere.

## Quality Management System

---

For information regarding Microchip's Quality Management Systems, please visit [www.microchip.com/quality](http://www.microchip.com/quality).



## Worldwide Sales and Service

AMERICAS	ASIA/PACIFIC	ASIA/PACIFIC	EUROPE
<b>Corporate Office</b> 2355 West Chandler Blvd. Chandler, AZ 85224-6199 Tel: 480-792-7200 Fax: 480-792-7277 Technical Support: <a href="http://www.microchip.com/support">www.microchip.com/support</a> Web Address: <a href="http://www.microchip.com">www.microchip.com</a>	<b>Australia - Sydney</b> Tel: 61-2-9868-6733 <b>China - Beijing</b> Tel: 86-10-8569-7000 <b>China - Chengdu</b> Tel: 86-28-8665-5511 <b>China - Chongqing</b> Tel: 86-23-8980-9588 <b>China - Dongguan</b> Tel: 86-769-8702-9880 <b>China - Guangzhou</b> Tel: 86-20-8755-8029 <b>China - Hangzhou</b> Tel: 86-571-8792-8115 <b>China - Hong Kong SAR</b> Tel: 852-2943-5100 <b>China - Nanjing</b> Tel: 86-25-8473-2460 <b>China - Qingdao</b> Tel: 86-532-8502-7355 <b>China - Shanghai</b> Tel: 86-21-3326-8000 <b>China - Shenyang</b> Tel: 86-24-2334-2829 <b>China - Shenzhen</b> Tel: 86-755-8864-2200 <b>China - Suzhou</b> Tel: 86-186-6233-1526 <b>China - Wuhan</b> Tel: 86-27-5980-5300 <b>China - Xian</b> Tel: 86-29-8833-7252 <b>China - Xiamen</b> Tel: 86-592-2388138 <b>China - Zhuhai</b> Tel: 86-756-3210040	<b>India - Bangalore</b> Tel: 91-80-3090-4444 <b>India - New Delhi</b> Tel: 91-11-4160-8631 <b>India - Pune</b> Tel: 91-20-4121-0141 <b>Japan - Osaka</b> Tel: 81-6-6152-7160 <b>Japan - Tokyo</b> Tel: 81-3-6880-3770 <b>Korea - Daegu</b> Tel: 82-53-744-4301 <b>Korea - Seoul</b> Tel: 82-2-554-7200 <b>Malaysia - Kuala Lumpur</b> Tel: 60-3-7651-7906 <b>Malaysia - Penang</b> Tel: 60-4-227-8870 <b>Philippines - Manila</b> Tel: 63-2-634-9065 <b>Singapore</b> Tel: 65-6334-8870 <b>Taiwan - Hsin Chu</b> Tel: 886-3-577-8366 <b>Taiwan - Kaohsiung</b> Tel: 886-7-213-7830 <b>Taiwan - Taipei</b> Tel: 886-2-2508-8600 <b>Thailand - Bangkok</b> Tel: 66-2-694-1351 <b>Vietnam - Ho Chi Minh</b> Tel: 84-28-5448-2100	<b>Austria - Wels</b> Tel: 43-7242-2244-39 Fax: 43-7242-2244-393 <b>Denmark - Copenhagen</b> Tel: 45-4485-5910 Fax: 45-4485-2829 <b>Finland - Espoo</b> Tel: 358-9-4520-820 <b>France - Paris</b> Tel: 33-1-69-53-63-20 Fax: 33-1-69-30-90-79 <b>Germany - Garching</b> Tel: 49-8931-9700 <b>Germany - Haan</b> Tel: 49-2129-3766400 <b>Germany - Heilbronn</b> Tel: 49-7131-72400 <b>Germany - Karlsruhe</b> Tel: 49-721-625370 <b>Germany - Munich</b> Tel: 49-89-627-144-0 Fax: 49-89-627-144-44 <b>Germany - Rosenheim</b> Tel: 49-8031-354-560 <b>Israel - Ra'anana</b> Tel: 972-9-744-7705 <b>Italy - Milan</b> Tel: 39-0331-742611 Fax: 39-0331-466781 <b>Italy - Padova</b> Tel: 39-049-7625286 <b>Netherlands - Drunen</b> Tel: 31-416-690399 Fax: 31-416-690340 <b>Norway - Trondheim</b> Tel: 47-72884388 <b>Poland - Warsaw</b> Tel: 48-22-3325737 <b>Romania - Bucharest</b> Tel: 40-21-407-87-50 <b>Spain - Madrid</b> Tel: 34-91-708-08-90 Fax: 34-91-708-08-91 <b>Sweden - Gothenberg</b> Tel: 46-31-704-60-40 <b>Sweden - Stockholm</b> Tel: 46-8-5090-4654 <b>UK - Wokingham</b> Tel: 44-118-921-5800 Fax: 44-118-921-5820
<b>Atlanta</b> Duluth, GA Tel: 678-957-9614 Fax: 678-957-1455 <b>Austin, TX</b> Tel: 512-257-3370 <b>Boston</b> Westborough, MA Tel: 774-760-0087 Fax: 774-760-0088 <b>Chicago</b> Itasca, IL Tel: 630-285-0071 Fax: 630-285-0075 <b>Dallas</b> Addison, TX Tel: 972-818-7423 Fax: 972-818-2924 <b>Detroit</b> Novi, MI Tel: 248-848-4000 <b>Houston, TX</b> Tel: 281-894-5983 <b>Indianapolis</b> Noblesville, IN Tel: 317-773-8323 Fax: 317-773-5453 Tel: 317-536-2380 <b>Los Angeles</b> Mission Viejo, CA Tel: 949-462-9523 Fax: 949-462-9608 Tel: 951-273-7800 <b>Raleigh, NC</b> Tel: 919-844-7510 <b>New York, NY</b> Tel: 631-435-6000 <b>San Jose, CA</b> Tel: 408-735-9110 Tel: 408-436-4270 <b>Canada - Toronto</b> Tel: 905-695-1980 Fax: 905-695-2078			

SYST-02TWJB455 - Dat 768 x 8) Data Sheet Document Revision

Affected Catalog Part Numbers(CPN)

AT24C256C-WWU11L  
AT24C256C-SSHL-B  
AT24C256C-XHL-B  
AT24C256C-SSHL-T  
AT24C256C-SSHL-T-989  
AT24C256C-XHL-T  
AT24C256C-CUL-T  
AT24C256C-MAHL-T  
AT24C256C-MAHL-E  
AT24C256C-WWU27L  
AT24C256C-WWU7L  
AT24C256C-SSHLNP-T  
AT24C256C-CULEU-T