

ECN/PCN No.: M1350

### For Manufacturer

<b>Product Description:</b> RJ45 10/100 Base-T Vertical with Magnetic Module	<b>Abracon Part Number / Part Series:</b> ARJ11G Series	<input type="checkbox"/> Documentation only <input checked="" type="checkbox"/> ECN <input type="checkbox"/> EOL	<input checked="" type="checkbox"/> Series <input type="checkbox"/> Part Number(s)
<b>Affected Revision:</b> B	<b>New Revision:</b> C	<b>Application:</b>	<input type="checkbox"/> Safety <input checked="" type="checkbox"/> Non-Safety

**Prior to Change:**  
 MA configuration

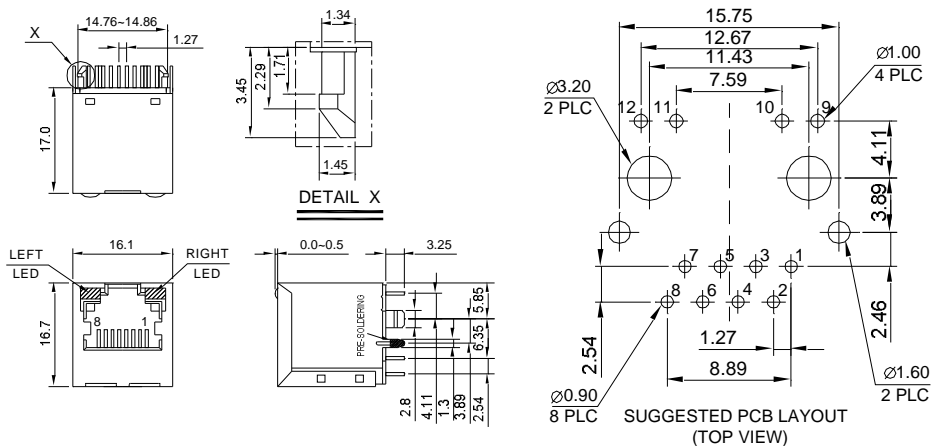

**After Change:**  
 MA Configuration

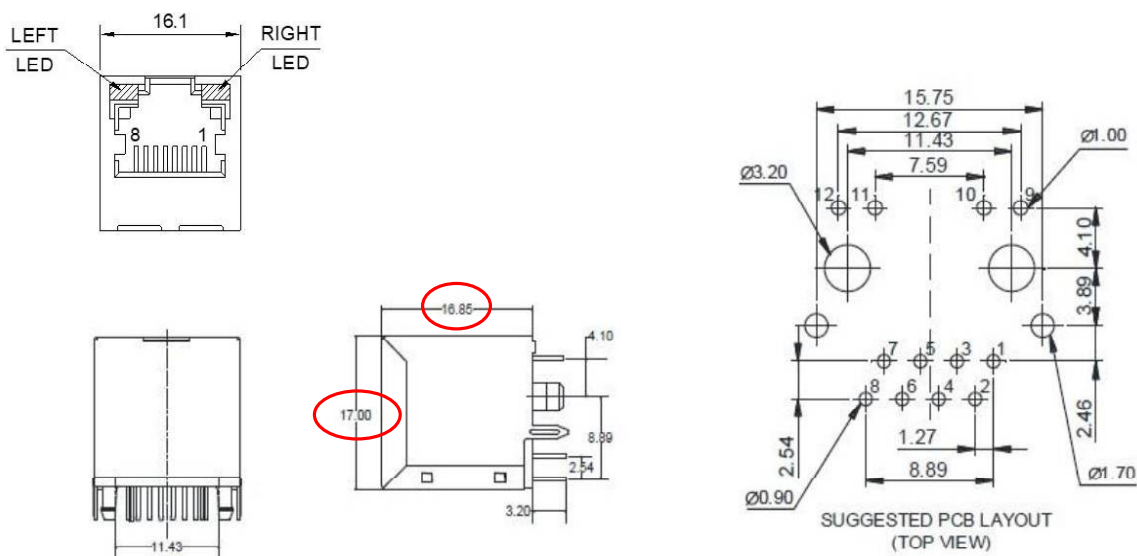

Cosmetic Differences

**Before    After**

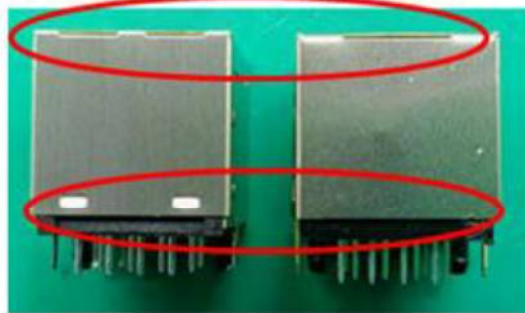
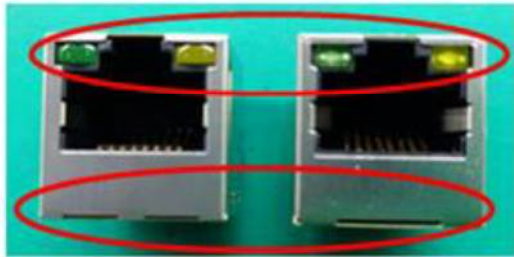

<b>Cause/Reason for Change:</b> Raw material supply chain required change to different shield/shell.		
<b>Change Plan</b>		
<b>Effective Date:</b> 4/25/2022	<b>Additional Remarks:</b>	
<b>Change Declaration:</b> Outline of MA configuration has changed slightly and attention must be placed on impact to customer panel cutout. There are slight cosmetic differences as well. The changes here do not affect the products electrical function.		
<b>Issued Date:</b> 4/25/2022	<b>Issued By:</b> <i>Gerald Capwell</i>	<b>Issued Department:</b> Engineering
<b>Approval:</b> <i>Syed Raza</i> Engineering VP	<b>Approval:</b> <i>Reuben Quintanilla</i> Quality Director	<b>Approval:</b> <i>Ying Huang</i> Purchasing Director
<b>For Abracon EOL only</b>		
<b>Last Time Buy (if applicable):</b>		<b>Alternate Part Number / Part Series:</b>
<b>Additional Approval:</b>	<b>Additional Approval:</b>	<b>Additional Approval:</b>
<b>Customer Approval (If Applicable)</b>		
<b>Qualification Status:</b> <div style="text-align: center;"> <input type="checkbox"/> Approved <input type="checkbox"/> Not accepted         </div> <i>Note: It is considered approved if there is no feedback from the customer 1 month after ECN/PCN is released.</i>		
<b>Customer Part Number:</b>		<b>Customer Project:</b>
<b>Company Name:</b>	<b>Company Representative:</b>	<b>Representative Signature:</b>
<b>Customer Remarks:</b>		