

# Information note

N° 090/21

Dear customer,

With this Infineon Technologies AG information note, we would like to inform you about the following

## Datasheet update: corrected description of package marking



On 16 April 2020, Infineon acquired Cypress.  
We are now in the process of merging and consolidating our tools and processes for PCN, Information Notes, Errata and Product Discontinuance.  
For further details, please visit our website:  
<https://www.infineon.com/cms/en/about-infineon/company/cypress-acquisition/>

Infineon Technologies AG  
Postal Address Headquarters: Am Campeon 1-15, D-85579 Neubiberg, Phone +49 (0)89 234-0  
Chairman of the Supervisory Board: Dr. Wolfgang Eder  
Management Board: Dr. Reinhard Ploss (CEO), Dr. Helmut Gassel, Jochen Hanebeck, Constanze Hufenbecher, Dr. Sven Schneider  
Registered Office: Neubiberg  
Commercial Register: München HRB 126492

# Information note

N° 090/21

- ▶ **Products affected** Please refer to attached affected product list 1\_cip09021
  
- ▶ **Detailed change information**

<b>Subject</b>	Datasheet update: corrected description of package marking	
<b>Reason</b>	Datasheet update – editorial changes	
<b>Description</b>	<u>Old</u>	<u>New</u>
	■ Rev. 1.0	■ Rev. 1.01
  
- ▶ **Product identification** not applicable (for documentation only)
  
- ▶ **Impact of change** not applicable (for documentation only)
  
- ▶ **Attachments**

1_cip09021	affected product list
3_cip09021	customer information package
4_cip09021	datasheet revision 1.01
  
- ▶ **Intended start of delivery** Not applicable

If you have any questions, please do not hesitate to contact your local sales office.

# OPTIREG™ switcher TLE8386-2EL

## Basic smart boost controller



### Features

- Wide input voltage range from 4.75 V to 45 V
- Constant current regulation
- Constant voltage regulation
- Very low shutdown current:  $I_q < 2 \mu\text{A}$
- Flexible switching frequency range, 100 kHz to 700 kHz
- Synchronization with external clock source
- Available in a small thermally enhanced PG-SSOP-14 package
- Internal 5 V low drop out voltage regulator
- Output overvoltage protection
- External soft start adjustable by capacitor
- Overtemperature shutdown
- Green Product (RoHS) Compliant

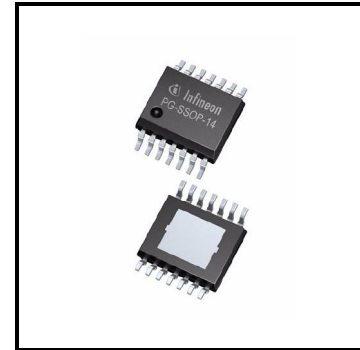

### Potential applications

- Step up converter
- Voltage stabilization during cold cranking
- SEPIC
- Flyback converter

### Product validation

Qualified for automotive applications. Product validation according to AEC-Q100.

### Description

The TLE8386-2EL is a boost controller with built in protection features. The main function of this device is to boost (step-up) an input voltage to a higher output voltage. The switching frequency is adjustable from 100 kHz to 700 kHz and can be synchronized with an external clock. The TLE8386-2EL features an enable function reducing shut-down current consumption to less than 2  $\mu\text{A}$ . The current mode regulation scheme of this device provides a stable regulation loop maintained by small external compensation components. The integrated soft-start feature with external components for adjustment limits the current peak as well as voltage overshoot at start-up. This IC is suited for use in harsh automotive environment and provides output overvoltage protection and overtemperature shutdown.

**OPTIREG™ switcher TLE8386-2EL**  
**Basic smart boost controller**

---



<b>Type</b>	<b>Package</b>	<b>Marking</b>
TLE8386-2EL	PG-SSOP-14	8386-2EL

## Table of contents

<b>1</b>	<b>Block diagram</b> .....	<b>4</b>
<b>2</b>	<b>Pin configuration</b> .....	<b>5</b>
2.1	Pin assignment .....	5
2.2	Pin definitions and functions .....	5
<b>3</b>	<b>General product characteristics</b> .....	<b>7</b>
3.1	Absolute maximum ratings .....	7
3.2	Functional range .....	8
3.3	Thermal resistance .....	9
<b>4</b>	<b>Boost regulator</b> .....	<b>10</b>
4.1	Functional description boost regulator .....	10
4.2	Electrical characteristics boost regulator .....	11
<b>5</b>	<b>Oscillator and synchronization</b> .....	<b>14</b>
5.1	Functional description oscillator and synchronization .....	14
5.2	Electrical characteristics oscillator and synchronization .....	15
<b>6</b>	<b>Enable function</b> .....	<b>17</b>
6.1	Functional description enable function .....	17
6.2	Electrical characteristics enable function .....	18
<b>7</b>	<b>Linear regulator</b> .....	<b>19</b>
7.1	Functional description linear regulator .....	19
7.2	Electrical characteristics linear regulator .....	20
<b>8</b>	<b>Protection and diagnostic functions</b> .....	<b>21</b>
8.1	Functional description Protection and diagnostic functions .....	21
8.2	Electrical characteristics protection functions .....	21
<b>9</b>	<b>Application information</b> .....	<b>22</b>
9.1	Boost converter application circuit .....	22
9.1.1	Principle .....	23
9.1.2	Component selection .....	24
9.2	Further information on TLE8386-2EL .....	28
9.2.1	General layout recommendations .....	28
9.2.2	Additional information .....	30
<b>10</b>	<b>Package information</b> .....	<b>31</b>
<b>11</b>	<b>Revision history</b> .....	<b>32</b>

**Block diagram**

**1 Block diagram**

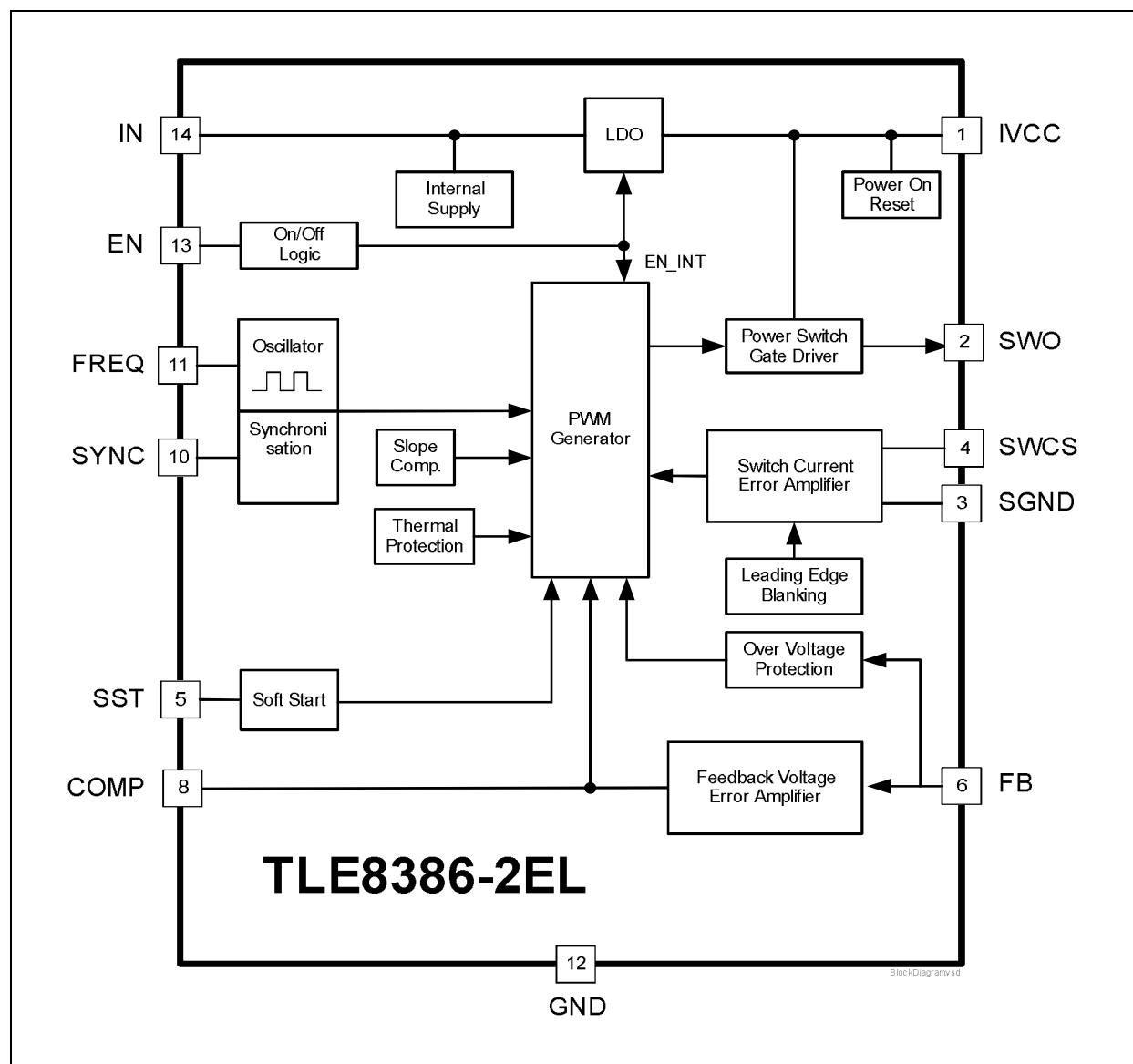
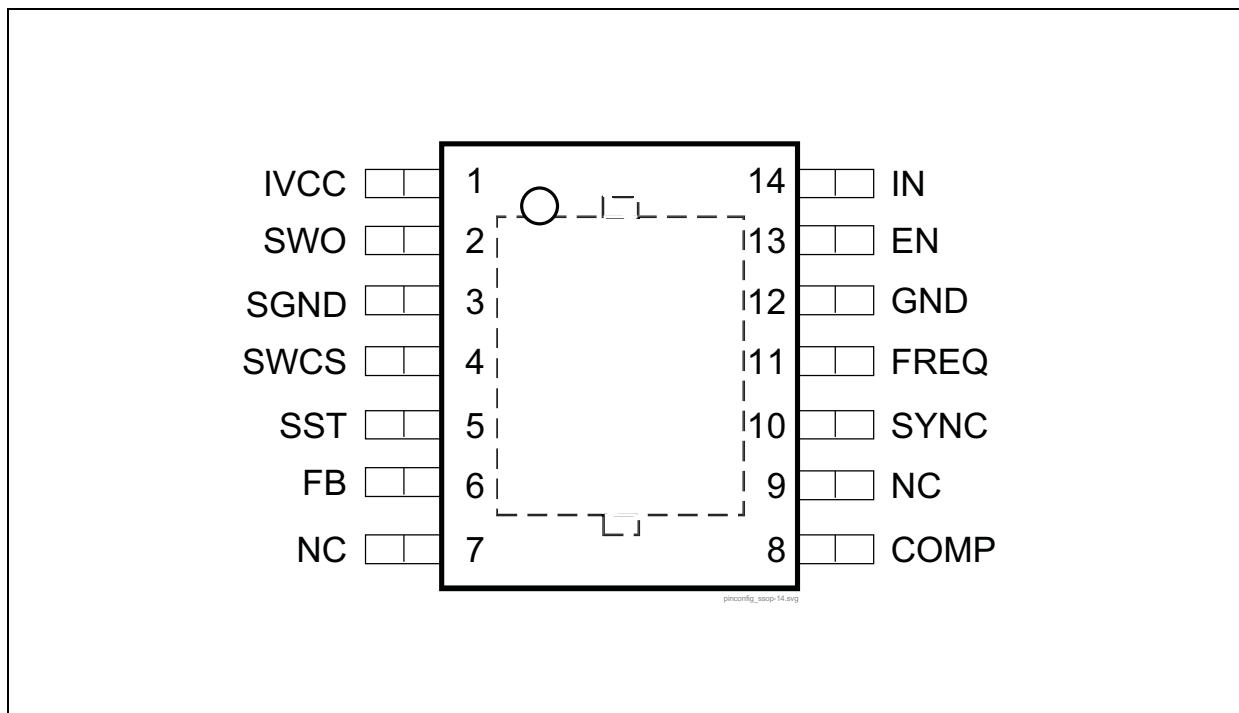

**Figure 1 Block diagram**

**Pin configuration**

**2 Pin configuration**

**2.1 Pin assignment**



**Figure 2 Pin assignment**

**2.2 Pin definitions and functions**

Pin	Symbol	Function
1	IVCC	<b>Internal LDO output</b> Used for internal biasing and gate drive. Do not leave open, bypass with external capacitor. Do not connect other circuitry to this pin.
2	SWO	<b>Switch output</b> Connect to the gate of external boost converter switching MOSFET.
3	SGND	<b>Current sense ground</b> Ground return for current sense switch, connect to bottom side of sense resistor.
4	SWCS	<b>Current sense input</b> Detects the peak current through switch, connect to high side of sense resistor.
5	SST	<b>Soft start</b> Connect an external capacitor to adjust the soft start ramp, do not leave open.
6	FB	<b>Feedback</b> Output voltage feedback, connect to output voltage via resistor divider from output capacitor to ground.
7	NC	<b>Not connected</b> -

**Pin configuration**

<b>Pin</b>	<b>Symbol</b>	<b>Function</b>
8	COMP	<b>Compensation input</b> Connect R and C network to improve stability of the regulation loop.
9	NC	<b>Not connected</b> -
10	SYNC	<b>Sync</b> Synchronization Input; if synchronization feature is not used, leave open.
11	FREQ	<b>Frequency select input</b> Connect external resistor to GND to set frequency, do not leave open.
12	GND	<b>Ground</b> Connect to system ground.
13	EN	<b>Enable</b> Apply logic high signal to enable device.
14	IN	<b>Supply input</b> Supply for internal biasing, connect to input voltage.
Exposed Pad		Connect to GND.



**General product characteristics**

### 3 General product characteristics

#### 3.1 Absolute maximum ratings

**Table 1 Absolute maximum ratings<sup>1)</sup>**

$T_j = -40^\circ\text{C}$  to  $+150^\circ\text{C}$ ; all voltages with respect to ground, positive current flowing into pin;  
(unless otherwise specified)

Parameter	Symbol	Values			Unit	Note or Test Condition	Number
		Min.	Typ.	Max.			
<b>Voltages</b>							
IN Supply input	$V_{IN}$	-0.3	-	45	V	-	P_4.1.1
EN Enable input	$V_{EN}$	-40	-	45	V	-	P_4.1.2
FB Feedback error amplifier input	$V_{FB}$	-0.3	-	5.5	V	-	P_4.1.3
		-0.3	-	6.2	V	$t < 10\text{ s}$	P_4.1.4
SWCS Switch current sense input	$V_{SWCS}$	-0.3	-	5.5	V	-	P_4.1.5
		-0.3	-	6.2	V	$t < 10\text{ s}$	P_4.1.6
SWO Switch gate drive output	$V_{SWO}$	-0.3	-	5.5	V	-	P_4.1.7
		-0.3	-	6.2	V	$t < 10\text{ s}$	P_4.1.8
SGND Current sense switch GND	$V_{SGND}$	-0.3	-	0.3	V	-	P_4.1.9
COMP Compensation input	$V_{COMP}$	-0.3	-	5.5	V	-	P_4.1.10
		-0.3	-	6.2	V	$t < 10\text{ s}$	P_4.1.11
FREQ Frequency input	$V_{FREQ}$	-0.3	-	5.5	V	-	P_4.1.12
		-0.3	-	6.2	V	$t < 10\text{ s}$	P_4.1.13
SYNC Synchronization input	$V_{SYNC}$	-0.3	-	5.5	V	-	P_4.1.14
		-0.3	-	6.2	V	$t < 10\text{ s}$	P_4.1.15
SST Soft start setting input	$V_{SST}$	-0.3	-	5.5	V	-	P_4.1.16
		-0.3	-	6.2	V	$t < 10\text{ s}$	P_4.1.17
IVCC Internal linear voltage regulator output	$V_{IVCC}$	-0.3	-	5.5	V	-	P_4.1.18
		-0.3	-	6.2	V	$t < 10\text{ s}$	P_4.1.19
<b>Temperatures</b>							
Junction temperature	$T_j$	-40	-	150	°C	-	P_4.1.20
Storage temperature	$T_{stg}$	-55	-	150	°C	-	P_4.1.21

**General product characteristics**

**Table 1 Absolute maximum ratings<sup>1)</sup>** (cont'd)

$T_j = -40^\circ\text{C}$  to  $+150^\circ\text{C}$ ; all voltages with respect to ground, positive current flowing into pin;  
(unless otherwise specified)

Parameter	Symbol	Values			Unit	Note or Test Condition	Number
		Min.	Typ.	Max.			
<b>ESD susceptibility</b>							
ESD resistivity to GND	$V_{\text{ESD,HBM}}$	-2	-	2	kV	HBM <sup>2)</sup>	P_4.1.22
ESD resistivity to GND	$V_{\text{ESD,CDM}}$	-500	-	500	V	CDM <sup>3)</sup>	P_4.1.23
ESD resistivity pin 1, 7, 8, 14 (corner pins) to GND	$V_{\text{ESD,CDM,C}}$	-750	-	750	V	CDM <sup>3)</sup>	P_4.1.24

- 1) Not subject to production test, specified by design.
- 2) ESD susceptibility, Human Body Model “HBM” according to EIA/JESD 22-A114B.
- 3) ESD susceptibility, Charged Device Model “CDM” EIA/JESD22-C101 or ESDA STM5.3.1.

**Notes**

1. Stresses above the ones listed here may cause permanent damage to the device. Exposure to absolute maximum rating conditions for extended periods may affect device reliability.
2. Integrated protection functions are designed to prevent IC destruction under fault conditions described in the datasheet. Fault conditions are considered as “outside” normal operating range. Protection functions are not designed for continuous repetitive operation.

**3.2 Functional range**

**Table 2 Functional range**

Parameter	Symbol	Values			Unit	Note or Test Condition	Number
		Min.	Typ.	Max.			
Supply voltage input	$V_{\text{IN}}$	4.75	-	45	V	$V_{\text{IVCC}} > V_{\text{IVCC,RTH,d}}$	P_4.2.1

*Note:* Within the functional range the IC operates as described in the circuit description. The electrical characteristics are specified within the conditions given in the related electrical characteristics table.

**General product characteristics**

**3.3 Thermal resistance**

*Note:* This thermal data was generated in accordance with JEDEC JESD51 standards. For more information, go to [www.jedec.org](http://www.jedec.org).

**Table 3 Thermal resistance**

Parameter	Symbol	Values			Unit	Note or Test Condition	Number
		Min.	Typ.	Max.			
Junction to case <sup>1)</sup>	$R_{thJC}$	–	10	–	K/W	–	P_4.3.1
Junction to ambient <sup>1)2)</sup>	$R_{thJA}$	–	47	–	K/W	2s2p	P_4.3.2
	$R_{thJA}$	–	54	–	K/W	1s0p + 600 mm <sup>2</sup>	P_4.3.3
	$R_{thJA}$	–	64	–	K/W	1s0p + 300 mm <sup>2</sup>	P_4.3.4

1) Not subject to production test, specified by design.

2) Specified  $R_{thJA}$  value is according to JEDEC 2s2p (JESD 51-7) + (JESD 51-5) and JEDEC 1s0p (JESD 51-3) + heatsink area at natural convection on FR4 board.

**Boost regulator**

**4 Boost regulator**

**4.1 Functional description boost regulator**

The TLE8386-2EL boost (step-up) regulator provides a higher output voltage than input voltage. The PWM controller measures the output voltage via a resistor divider connected between FB pin and ground, and determines the appropriate pulse width duty cycle (on time). Overvoltage protection switches off the converter in case the voltage at FB pin exceeds overvoltage limit. In case of loss of connection to the output voltage resistor divider, an internal current source connected to FB pin will draw the voltage above this limit and shut the external MOSFET off. The current mode controller has a built-in slope compensation to prevent sub-harmonic oscillations which is a characteristic of current mode controllers operating at high duty cycle ( $D > 50\%$ ). An additional feature is integrated soft start which limits current through the inductor and the through the external power switch during initialization.

The soft-start time  $T_{SS}$  is adjustable using an external capacitor  $C_{SST}$ :

$$T_{SS} = C_{SST} \times \frac{2,00V}{10\mu A} \tag{4.1}$$

The switching frequency may be adjusted by using an external resistor (please refer to [Chapter 5 Oscillator and synchronization](#)). When synchronizing with an external clock, the internal frequency has to be adjusted close to the external clock frequency.

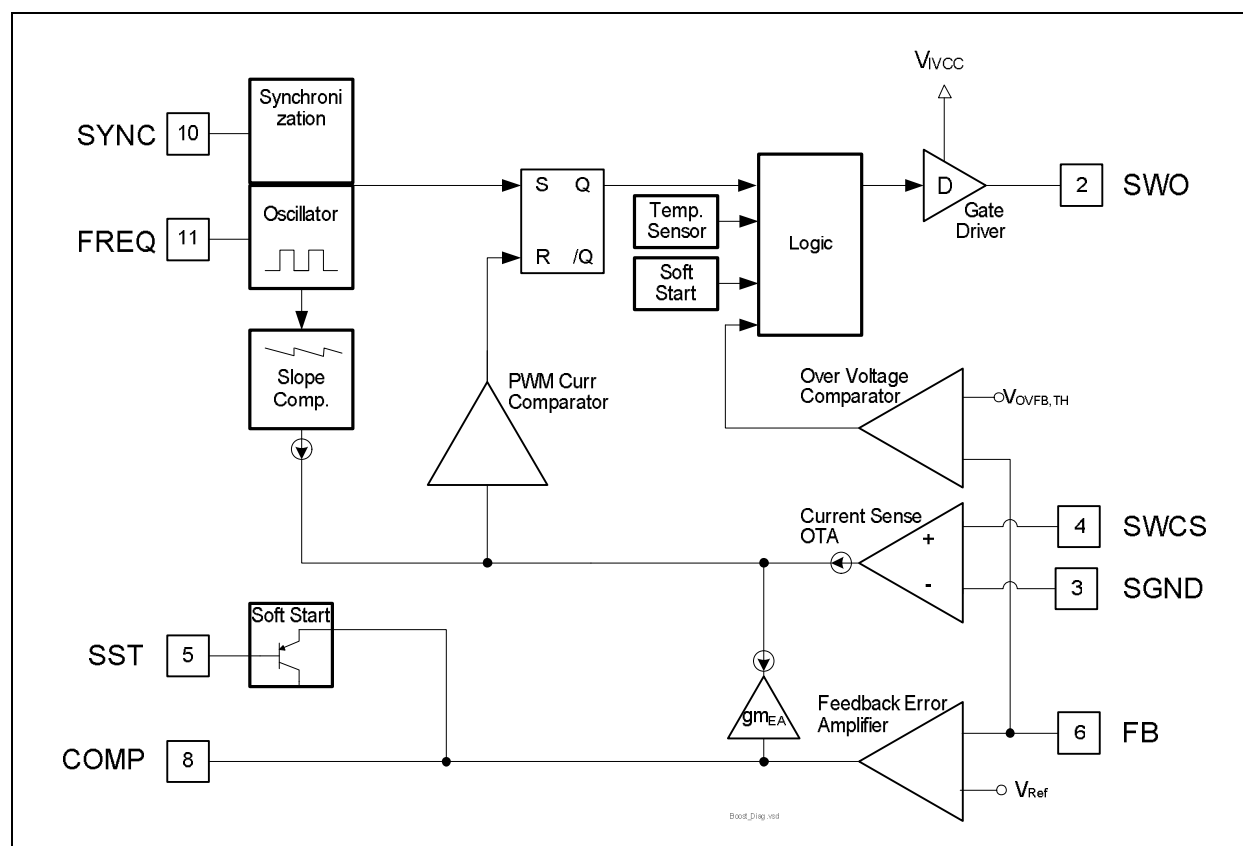

**Figure 3 Boost regulator block diagram**

## Boost regulator

## 4.2 Electrical characteristics boost regulator

Table 4 Electrical characteristics boost regulator <sup>1)</sup>

$V_{IN} = 6\text{ V to }40\text{ V}$ ;  $T_j = -40^\circ\text{C to }+150^\circ\text{C}$ , all voltages with respect to ground, positive current flowing into pin; (unless otherwise specified)

Parameter	Symbol	Values			Unit	Note or Test Condition	Number
		Min.	Typ.	Max.			
<b>Boost regulator</b>							
Feedback reference voltage	$V_{FB}$	2.32	2.5	2.62	V	$V_{IN} = 19\text{ V}$ ; $I_{BO} = 100\text{ mA to }500\text{ mA}$	P_5.2.1
Voltage line regulation	$\Delta V_{REF}/\Delta V_{IN}$	-	-	0.15	%/V	$V_{IN} = 6\text{ to }19\text{ V}$ ; $V_{BO} = 30\text{ V}$ ; $I_{BO} = 100\text{ mA}$ <b>Figure 8</b>	P_5.2.2
Voltage load regulation	$\Delta V_{FB}/\Delta I_{BO}$	-	-	5	%/A	$V_{IN} = 13\text{ V}$ ; $V_{BO} = 30\text{ V}$ ; $I_{BO} = 100\text{ mA to }500\text{ mA}$ <b>Figure 8</b>	P_5.2.3
Switch peak overcurrent threshold	$V_{SWCS}$	120	150	180	mV	$V_{IN} = 6\text{ V}$ ; $V_{FB} < V_{FBOV}$ ; $V_{COMP} = 3.5\text{ V}$	P_5.2.4
Current to soft start setting capacitor	$I_{SST}$	-8	-10	-16	$\mu\text{A}$	-	P_5.2.5
Feedback input current	$I_{FB}$	-	-200	-	nA	-	P_5.2.6
Switch current sense input current	$I_{SWCS}$	-10	-50	-100	$\mu\text{A}$	$V_{SWCS} = 150\text{ mV}$	P_5.2.7
Input undervoltage shutdown	$V_{IN,off}$	3.75	-	-	V	$V_{IN}$ decreasing	P_5.2.8
Input voltage startup	$V_{IN,on}$	-	-	4.75	V	$V_{IN}$ increasing	P_5.2.9
<b>Gate driver for boost switch</b>							
Gate driver peak sourcing current	$I_{SWO,src}$	-	-380	-	mA	$V_{SWO} = 3.5\text{ V}$	P_5.2.10
Gate driver peak sinking current	$I_{SWO,snk}$	-	550	-	mA	$V_{SWO} = 1.5\text{ V}$	P_5.2.11
Gate driver output rise time	$t_{R,SWO}$	-	30	60	ns	$C_{L,SWO} = 3.3\text{ nF}$ ; $V_{SWO} = 1\text{ V to }4\text{ V}$	P_5.2.12
Gate driver output fall time	$t_{F,SWO}$	-	20	40	ns	$C_{L,SWO} = 3.3\text{ nF}$ ; $V_{SWO} = 1\text{ V to }4\text{ V}$	P_5.2.13
Gate driver output voltage	$V_{SWO}$	4.5	-	5.5	V	$C_{L,SWO} = 3.3\text{ nF}$ ;	P_5.2.14

1) Not subject to production test, specified by design.

**Boost regulator**

**Efficiency depending on  
input voltage  $V_{IN}$  and output current  $I_{BO}$**

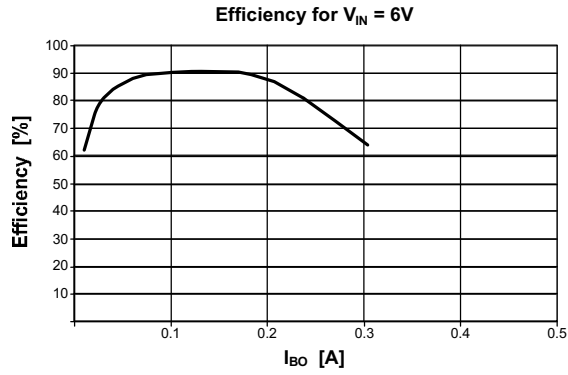

**Efficiency depending on  
input voltage  $V_{IN}$  and output current  $I_{BO}$**

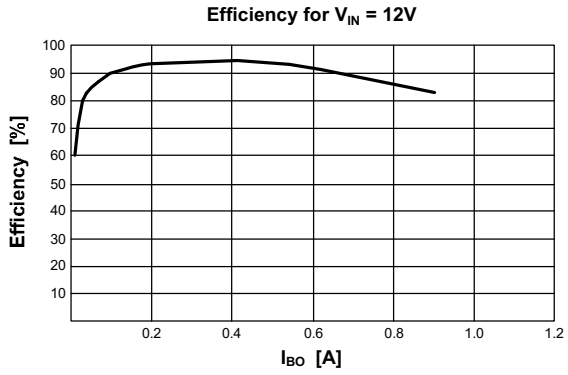

**Efficiency depending on  
input voltage  $V_{IN}$  and output current  $I_{BO}$**

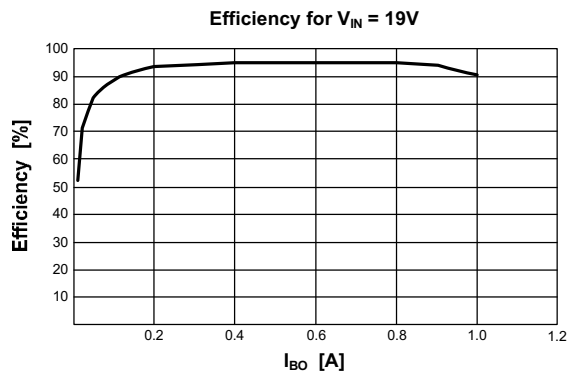

**Boost regulator**

**Load regulation**  
**input voltage  $V_{IN} = 6\text{ V}$**

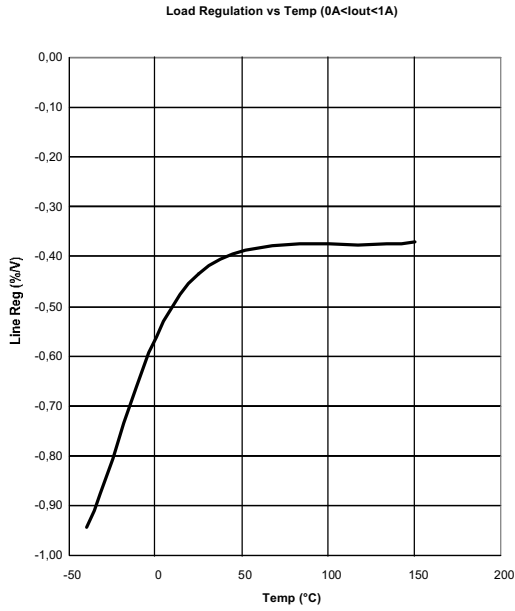

**Load regulation**  
**input voltage  $V_{IN} = 13.5\text{ V}$**

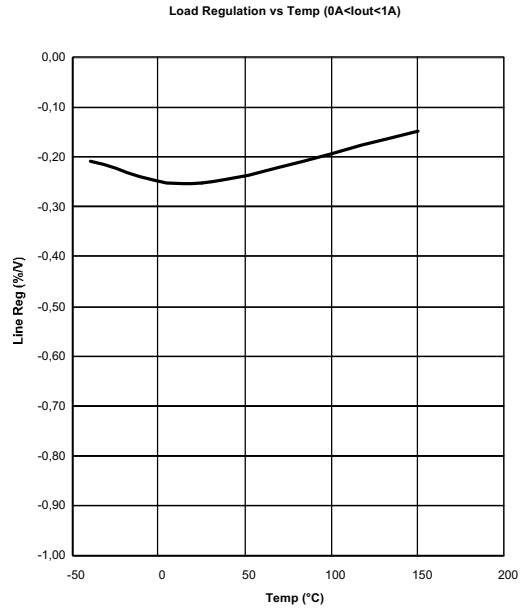

**Load regulation**  
**input voltage  $V_{IN} = 19\text{ V}$**

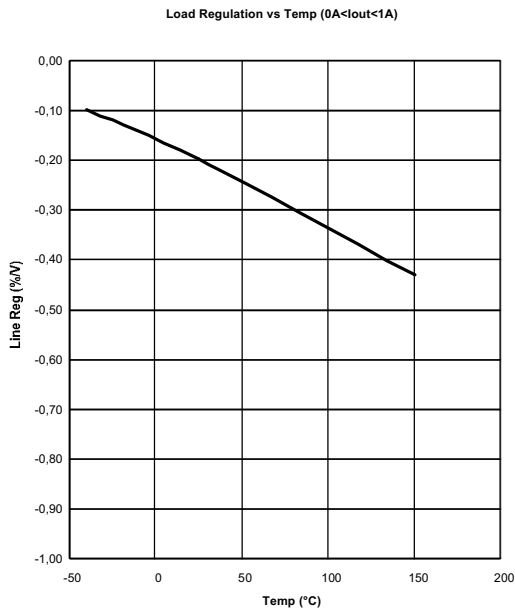

## 5 Oscillator and synchronization

### 5.1 Functional description oscillator and synchronization

The internal oscillator is used to determine the switching frequency of the boost regulator. The switching frequency can be selected from 100 kHz to 700 kHz with an external resistor to GND. The external resistor for setting switching frequency can be calculated by [Equation \(5.1\)](#):

$$R_{\text{FREQ}} = \frac{1}{(141 \times 10^{-12} [\frac{\text{S}}{\Omega}]) \times (f_{\text{FREQ}} [\frac{1}{\text{S}}])} - (3.5 \times 10^3 [\Omega]) [\Omega] \tag{5.1}$$

In addition, the oscillator is capable of changing from the frequency set by the external resistor to an external clock. If an external clock is provided at the SYNC pin, the internal oscillator should be set to about the same frequency. Boost regulator switching frequency is then synchronized with the external clock frequency. The synchronization frequency capture range is from 250 kHz to 700 kHz.

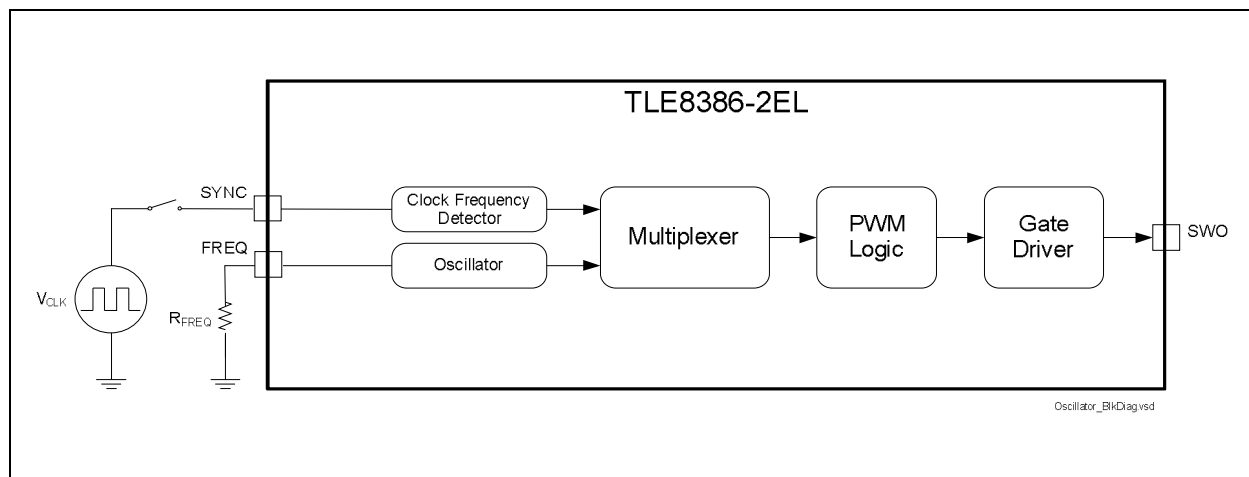

**Figure 4 Oscillator and synchronization block diagram and simplified application circuit**

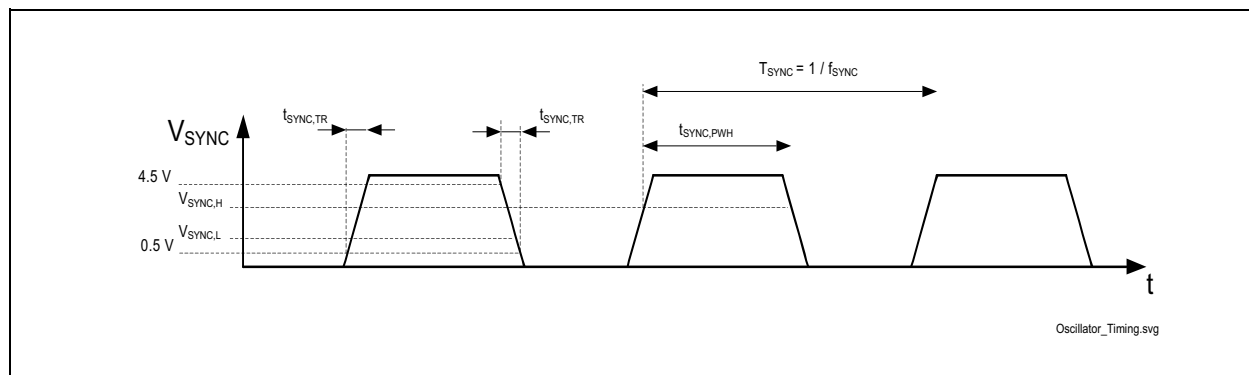

**Figure 5 Synchronization timing diagram**



## Oscillator and synchronization

## 5.2 Electrical characteristics oscillator and synchronization

Table 5 Electrical characteristics boost regulator

$V_{IN} = 6\text{ V to }40\text{ V}$ ;  $T_j = -40^\circ\text{C to }+150^\circ\text{C}$ , all voltages with respect to ground, positive current flowing into pin; (unless otherwise specified)

Parameter	Symbol	Values			Unit	Note or Test Condition	Number
		Min.	Typ.	Max.			
<b>Oscillator</b>							
Oscillator frequency	$f_{\text{FREQ}}$	250	300	350	kHz	$R_{\text{FREQ}} = 20\text{ k}\Omega$	P_6.2.1
Oscillator Frequency Adjustment range	$f_{\text{FREQ}}$	100	–	700	kHz	17% internal tolerance + external resistor tolerance	P_6.2.2
FREQ supply current	$I_{\text{FREQ}}$	–	–	-700	$\mu\text{A}$	$V_{\text{FREQ}} = 0\text{ V}$	P_6.2.3
<b>Synchronization</b>							
SYNC input internal pull-down	$R_{\text{SYNC}}$	150	250	350	k $\Omega$	$V_{\text{SYNC}} = 5\text{ V}$	P_6.2.4
Maximum duty cycle	$D_{\text{MAX, fixed}}$	90	93	95	%	Fixed frequency mode	P_6.2.5
Maximum duty cycle	$D_{\text{MAX, sync}}$	88	–	–	%	Synchronization mode, ratio between synchronization and internal frequency (set by resistor) is 0.8 to 1.2	P_6.2.6
Synchronization frequency capture range	$f_{\text{SYNC}}$	250	–	700	kHz	Ratio between synchronization and internal frequency (set by resistor) is 0.8 to 1.2	P_6.2.7
Synchronization signal duty cycle	$T_{\text{D, SYNC}}$	20	–	80	%	–	P_6.2.8
Synchronization signal High logic level valid	$V_{\text{SYNC, H}}$	3.0	–	–	V	<sup>1)</sup>	P_6.2.9
Synchronization signal Low logic level valid	$V_{\text{SYNC, L}}$	–	–	0.8	V	<sup>1)</sup>	P_6.2.10

1) Synchronization of external SWO ON signal to falling edge.

**Oscillator and synchronization**

**Typical performance characteristics of oscillator**

**Switching frequency  $f_{SW}$  versus  
frequency select resistor to GND  $R_{FREQ}$**

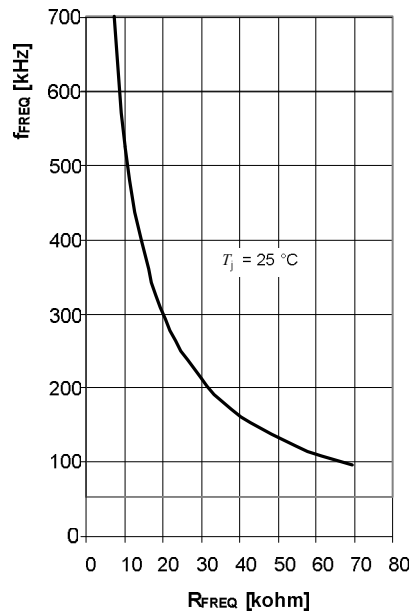

**Enable function**

**6 Enable function**

**6.1 Functional description enable function**

The enable function powers the device on or off. A valid logic low signal at enable pin EN powers the device off, reducing current consumption to less than 2 μA. A valid logic high signal at enable pin EN powers the device on.

Enable startup time  $t_{EN,START}$  is the period from recognizing a valid enable signal to the device starting to switch. During this time the internal supplies and the bandgap are initialized and reach their nominal values. The TLE8386-2EL will start switching after the nominal values are reached.

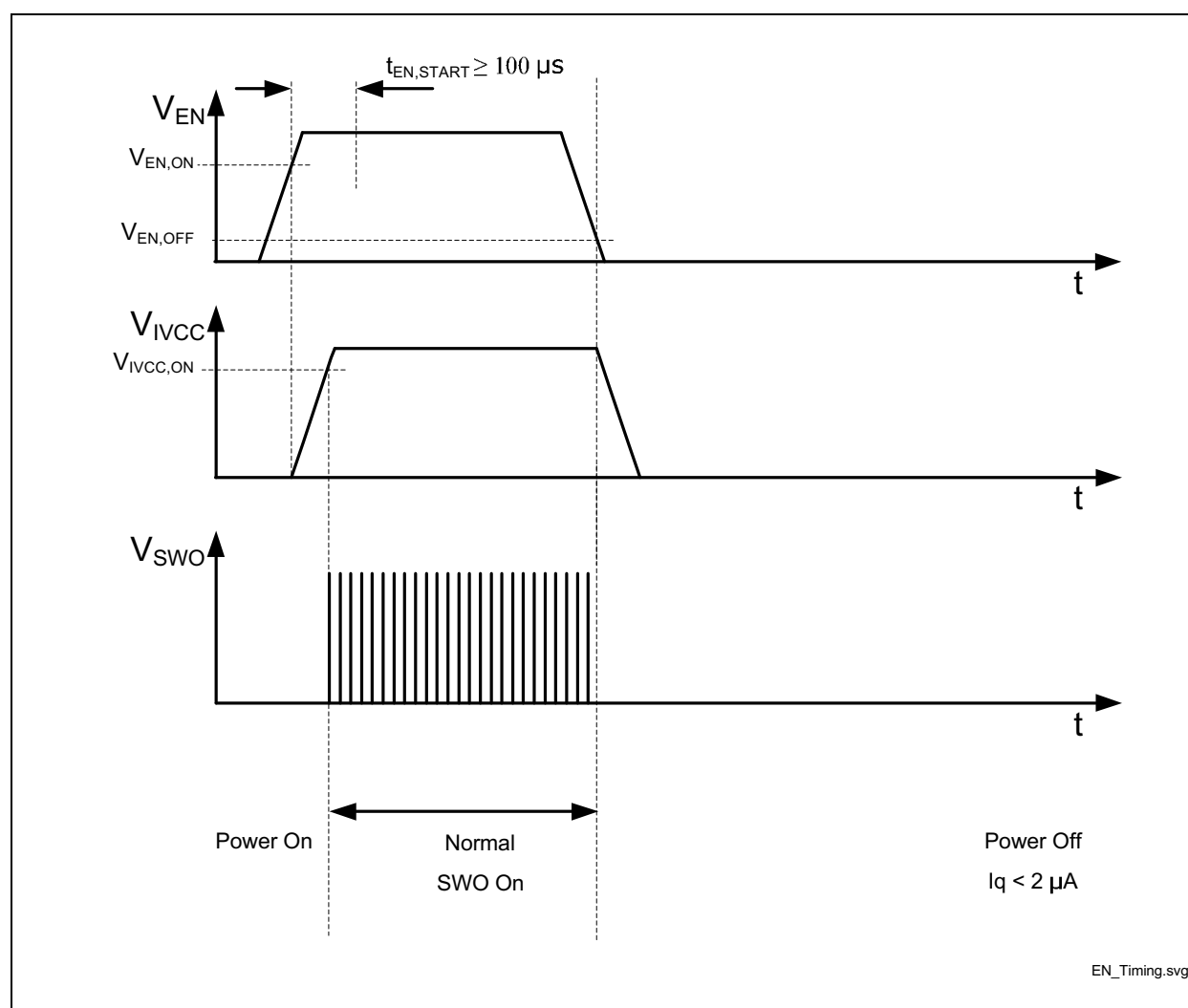

**Figure 6 Enable timing diagram**

**Enable function**

**6.2 Electrical characteristics enable function**

**Table 6 Electrical characteristics enable function**

$V_{IN} = 6\text{ V to }40\text{ V}$ ;  $T_j = -40^\circ\text{C to }+150^\circ\text{C}$ , all voltages with respect to ground, positive current flowing into pin; (unless otherwise specified)

Parameter	Symbol	Values			Unit	Note or Test Condition	Number
		Min.	Typ.	Max.			
<b>Enable input</b>							
Enable Turn on threshold	$V_{EN,ON}$	3.0	–	–	V	–	P_7.2.1
Enable Turn off threshold	$V_{EN,OFF}$	–	–	0.8	V	–	P_7.2.2
Enable hysteresis	$V_{EN,HYS}$	50	200	400	mV	–	P_7.2.3
Enable High input current	$I_{EN,H}$	–	–	30	$\mu\text{A}$	$V_{EN} = 16.0\text{ V}$	P_7.2.4
Enable Low input current	$I_{EN,L}$	–	0.1	1	$\mu\text{A}$	$V_{EN} = 0.5\text{ V}$	P_7.2.5
Enable startup time <sup>1)</sup>	$t_{EN,START}$	100	–	–	$\mu\text{s}$	–	P_7.2.6
<b>Current consumption</b>							
Current consumption, Shut-down mode	$I_{q,off}$	–	–	2	$\mu\text{A}$	$V_{EN} = 0.8\text{ V}$ ; $T_j \leq 105^\circ\text{C}$ ; $V_{IN} = 16\text{ V}$	P_7.2.7
Current consumption, Active mode <sup>2)</sup>	$I_{q,on}$	–	–	7	mA	$V_{EN} \geq 4.75\text{ V}$ ; $I_{BO} = 0\text{ mA}$ ; $V_{IN} = 16\text{ V}$ ; $V_{SWO} = 0\% \text{ duty}$	P_7.2.8

1) Not subject to production test, specified by design.

2) Dependency on switching frequency and gate charge of boost.

Linear regulator

## 7 Linear regulator

### 7.1 Functional description linear regulator

The internal linear voltage regulator supplies the internal gate drivers with a typical voltage of 5 V and current up to 50 mA. An external output filter capacitor with low ESR is required on IVCC pin for stabilizing and for buffering transient load current. During normal operation the external boost MOSFET switch will draw transient current from the linear regulator and its output capacitor. Proper dimensioning of the output filter capacitor must be considered to supply sufficient peak current to the gate of the external MOSFET switch. Please refer to [Chapter 9 Application information](#) for recommendations on dimensioning the output filter capacitor. An integrated power-on reset circuit monitors the linear regulator output voltage and resets the device in case the output voltage drops below the power-on reset threshold. Power-on reset helps protect external switches from excessive power dissipation by ensuring the gate drive voltage is sufficient to drive the gate of an external logic level n-channel MOSFET.

$V_{IVCC}$  remains at around 300 mV when enable signal is off. No external circuit should be connected to IVCC.

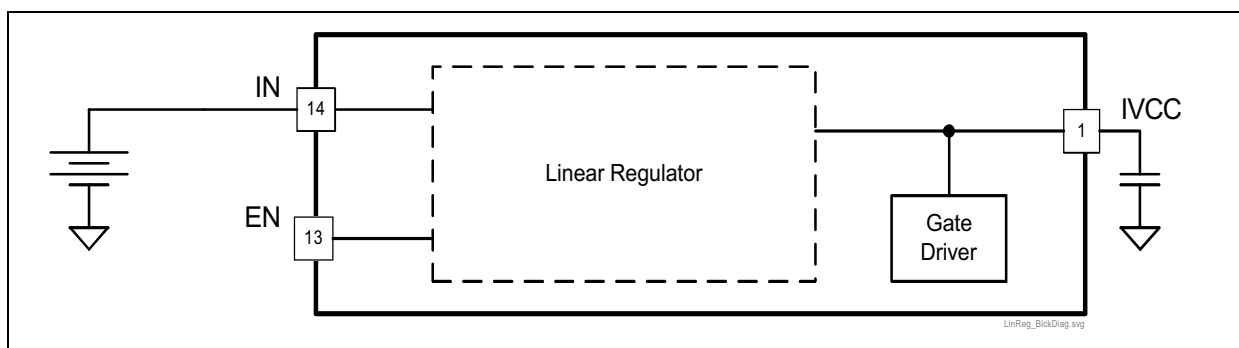

Figure 7 Voltage regulator block diagram and simplified application circuit

**Linear regulator**

**7.2 Electrical characteristics linear regulator**

**Table 7 Electrical characteristics linear regulator**

$V_{IN} = 6\text{ V to }40\text{ V}$ ;  $T_j = -40^\circ\text{C to }+150^\circ\text{C}$ , all voltages with respect to ground, positive current flowing into pin; (unless otherwise specified)

Parameter	Symbol	Values			Unit	Note or Test Condition	Number
		Min.	Typ.	Max.			
Output voltage	$V_{IVCC}$	4.6	5	5.4	V	$6\text{ V} \leq V_{IN} \leq 45\text{ V}$ ; $0.1\text{ mA} \leq I_{IVCC} \leq 50\text{ mA}$	P_8.2.1
Output current limitation	$I_{LIM}$	51	–	110	mA	$V_{IN} = 13.5\text{ V}$ ; $V_{IVCC} = 4.5\text{ V}$	P_8.2.2
Drop out voltage	$V_{DR}$	–	–	1000	mV	$I_{IVCC} = 50\text{ mA}$ <sup>1)</sup>	P_8.2.3
Output capacitor	$C_{IVCC}$	0.47	–	3	$\mu\text{F}$	<sup>2)</sup>	P_8.2.4
Output capacitor ESR	$R_{IVCC,ESR}$	–	–	0.5	$\Omega$	$f = 10\text{ kHz}$	P_8.2.5
Undervoltage reset headroom	$V_{IVCC,HDRM}$	100	–	–	mV	$V_{IVCC}$ decreasing $V_{IVCC} - V_{IVCC,RTH,d}$	P_8.2.6
Undervoltage reset threshold	$V_{IVCC,RTH,d}$	4.0	–	–	V	$V_{IVCC}$ decreasing	P_8.2.7
Undervoltage reset threshold	$V_{IVCC,RTH,i}$	–	–	4.5	V	$V_{IVCC}$ increasing	P_8.2.8

1) Measured when the output voltage  $V_{CC}$  has dropped 100 mV from its nominal value.

2) Minimum value given is needed for regulator stability; application might need higher capacitance than the minimum.

## 8 Protection and diagnostic functions

### 8.1 Functional description Protection and diagnostic functions

The TLE8386-2EL has integrated output overvoltage protection, open feedback protection and overtemperature protection. During overvoltage the gate driver outputs SWO will turn off. In overtemperature condition the thermal shutdown function turns off the gate drivers and the internal linear voltage regulator. In case of loss of connection from FB pin to the output voltage resistor divider, an internal current source connected to FB pin will raise the voltage above this limit and turn the external MOSFET off. The typical junction shutdown temperature is 175°C. After cooling down the IC will automatically restart operation. Thermal shutdown is an integrated protection function designed to prevent immediate IC destruction and is not intended for continuous use in normal operation.

### 8.2 Electrical characteristics protection functions

**Table 8 Electrical characteristics protection functions**

$V_{IN} = 6\text{ V to }40\text{ V}$ ;  $T_j = -40^\circ\text{C to }+150^\circ\text{C}$ , all voltages with respect to ground, positive current flowing into pin; (unless otherwise specified)

Parameter	Symbol	Values			Unit	Note or Test Condition	Number
		Min.	Typ.	Max.			
<b>Temperature protection</b>							
Overtemperature shutdown	$T_{j,SD}$	160	175	190	°C	–	P_9.2.1
Overtemperature shutdown hystereses	$T_{j,SD,HYST}$	–	15	–	°C	–	P_9.2.2
<b>Overvoltage protection</b>							
Output overvoltage feedback threshold Increasing	$V_{OVFB,TH}$	8	10	12	%	10% higher of regulated voltage	P_9.2.3
Output overvoltage feedback hysteresis	$V_{OVFB,HYS}$	–	5	–	%	Output voltage decreasing	P_9.2.4
Overvoltage reaction time	$t_{OVPRR}$	2	–	10	µs	Output voltage decreasing	P_9.2.5

*Note: Integrated protection functions are designed to prevent IC destruction under fault conditions described in the datasheet. Fault conditions are considered as “outside” normal operating range. Protection functions are not designed for continuous repetitive operation.*

**Application information**

**9 Application information**

*Note: The following information is given as a hint for the implementation of the device only and shall not be regarded as a description or warranty of a certain functionality, condition or quality of the device.*

**9.1 Boost converter application circuit**

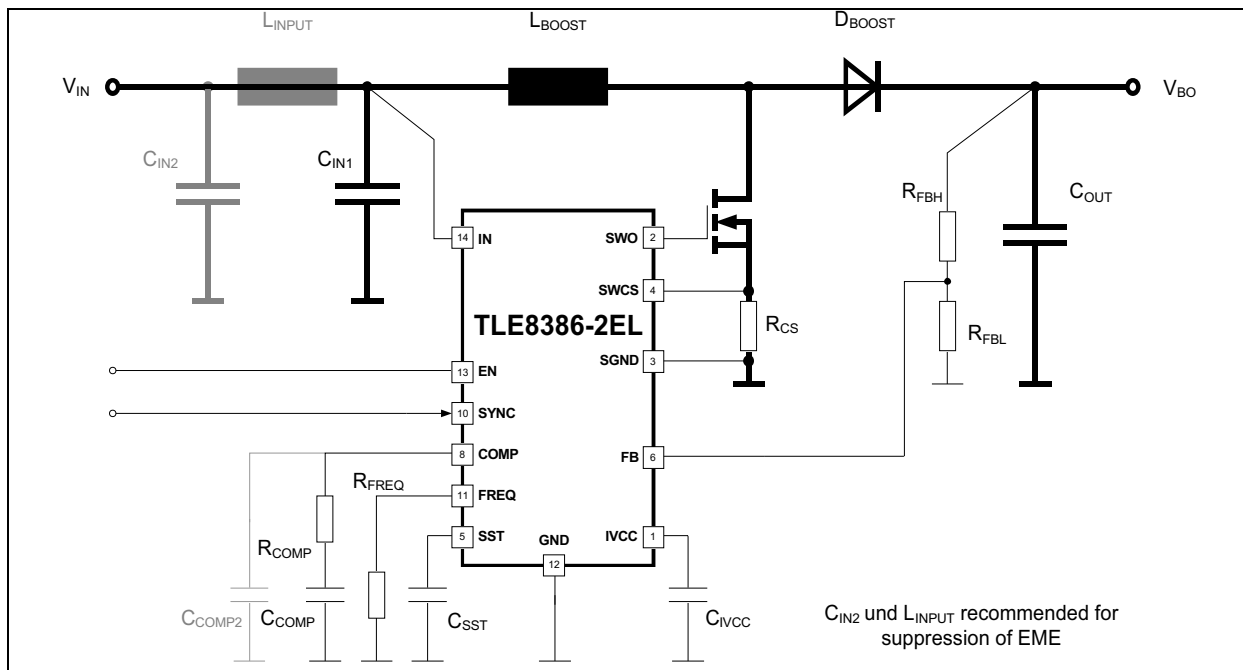

**Figure 8 Boost converter application circuit**

Reference Designator	Value	Manufacturer	Part Number	Type	Quantity
D <sub>BOOST</sub>	Schottky, 3 A, 100 V <sub>R</sub>	Vishay	SS3H10	Diode	1
C <sub>OUT</sub>	100 uF, 80V	Panasonic	EEVFK1K101Q	Capacitor	1
C <sub>IN1</sub>	100 uF, 50V	Panasonic	EEEFK1H101GP	Capacitor	1
C <sub>COMP</sub>	10 nF	--	--	Capacitor	1
C <sub>IVCC</sub>	100 uF, 6.3V	Panasonic	EEFHD0J101R	Capacitor	1
IC <sub>1</sub>	--	Infineon	TLE8386-2EL	IC	1
L <sub>BOOST</sub>	100 uH	Coilcraft	MSS1278T-104ML_	Inductor	1
R <sub>COMP</sub>	10 kΩ	Panasonic	ERJ3EKF1002V	Resistor	1
R <sub>FBH</sub>	11 kΩ, 1%	Panasonic	ERJ3EKF1102V	Resistor	1
R <sub>FBL</sub>	1 kΩ, 1%	Panasonic	ERJ3EKF1001V	Resistor	1
R <sub>FREQ</sub>	20 kΩ, 1%	Panasonic	ERJ3EKF2002V	Resistor	1
R <sub>CS</sub>	50 mΩ, 1%	Panasonic	ERJB1CFR05U	Resistor	1
C <sub>SST</sub>	4,7 nF	--	--	Capacitor	1

**Figure 9 Boost application circuit bill of material**

*Note: This is a simplified example of an application circuit. The function must be verified in the real application.*



## Application information

### 9.1.1 Principle

The TLE8386-2EL can be configured as a boost converter, where the desired output voltage  $V_{BO}$  is always higher than the input voltage  $V_{IN}$ . A boost converter is not short-circuit protected. If the output voltage  $V_{BO}$  is shorted, the output current will only be limited by the input voltage  $V_{IN}$  capability.

**Figure 8** shows a typical boost converter application circuit with the following components:

- $L_{BOOST}$  = boost inductor
- $L_{INPUT}$  = input filter inductor, recommended to reduce electromagnetic emissions
- $C_{IN1}$  = input filter capacitor
- $C_{IN2}$  = additional input filter capacitor, recommended to reduce electromagnetic emissions
- $C_{OUT}$  = output filter capacitor
- $D_{BOOST}$  = output diode
- $V_{IN}$  = input voltage
- $V_{INMIN}$  = minimum input voltage
- $V_{BO}$  = boost output voltage
- $R_{CS}$  = current sense resistor
- $R_{FBH}$  = boost output voltage resistor divider, high-side resistor
- $R_{FBL}$  = boost output voltage resistor divider, low-side resistor
- $R_{COMP}$ ,  $C_{COMP}$  = compensation network elements
- $R_{FREQ}$  = frequency setting resistor
- $C_{SST}$  = soft start setting capacitor
- $C_{IVCC}$  = capacitor for internal LDO
- $D$  = duty cycle
- $D_{MAX}$  = maximum duty cycle
- $f_{FREQ}$  = switching frequency
- $I_{IN}$  = input current
- $I_{BO}$  = output current
- $I_{BOMAX}$  = maximum output current

The ratio of input voltage  $V_{IN}$  and output voltage  $V_{BO}$  in continuous conduction mode (CCM) is:

$$\frac{V_{BO}}{V_{IN}} = \frac{1}{1 - D} \Leftrightarrow D = \frac{V_{BO} - V_{IN}}{V_{BO}} \quad (9.1)$$

In discontinuous conduction mode (DCM) the conversion ratio at a fixed frequency is higher, switching current increases and efficiency is reduced. The maximum duty cycle  $D_{MAX}$  occurs for minimum input voltage  $V_{INMIN}$ .

## Application information

### 9.1.2 Component selection

#### Power MOSFET selection

Important parameters for the choice of the power MOSFET are:

- Drain-source voltage rating  $V_{DS}$ :  
The power MOSFET will see the full output voltage  $V_{BO}$  plus the output diode ( $D_{BOOST}$ ) forward voltage. During its off-time additional ringing across drain-to-source will occur.
- On-resistance  $R_{DS(ON)}$  is relevant for efficiency and power dissipation
- Maximum drain current  $I_{D(MAX)}$
- Gate-to-source charge and gate-to-drain charge
- Thermal resistance

It is recommended to choose a power MOSFET with a drain-source voltage rating  $V_{DS}$  of at least 10 V higher than the output voltage  $V_{BO}$ .

The power dissipation  $P_{LOSSFET}$  in the power MOSFET can be calculated using [Equation \(9.2\)](#):

$$P_{LOSSFET} = I_{BOOSTMAX}^2 \times R_{DS(ON)} + 2 \times V_{BO}^2 \times I_{BOOSTMAX} \times C_{RSS} \times \frac{f_{FREQ}}{1A} \quad (9.2)$$

- $C_{RSS}$  = reverse transfer capacitance, please refer to power MOSFET datasheet
- $I_{BOOSTMAX}$  = maximum average current through the boost inductor  $L_{BOOST}$

The first term of [Equation \(9.2\)](#) gives the conduction losses in the power MOSFET, the second term the switching losses. To optimize the efficiency,  $R_{DS(ON)}$  and  $C_{RSS}$  should be minimized.

#### Current sense resistor RCS selection

For control and protection, the TLE8386-2EL measures the power MOSFET current by a current sense resistor  $R_{CS}$ , which is located between the power MOSFET source and ground. For proper function make sure the following:

- Place the current sense resistor as close as possible to the TLE8386-2EL
- Use short (low resistive and low inductive) traces between the power MOSFET source and ground
- Use short (low resistive and low inductive) traces between the current sense resistor  $R_{CS}$  high-side and low-side and the pins SWCS and SGND (it is not recommended to use pin GND instead of pin SGND for power MOSFET current measurement)
- The value of  $R_{CS}$  should be selected to ensure that the maximum peak sense voltage  $V_{SENSEPEAK}$  during steady state normal operation will be lower than the adjusted current limit threshold (current limit function). It is recommended to add a 20% margin.
- The value of  $R_{CS}$  should be selected to ensure that the power MOSFET maximum drain current  $I_{D(MAX)}$  will not be exceeded (please refer to power MOSFET datasheet)

**Application information**

**Figure 10** shows the voltage waveform at the current sense resistor  $R_{CS}$  during a switching cycle:

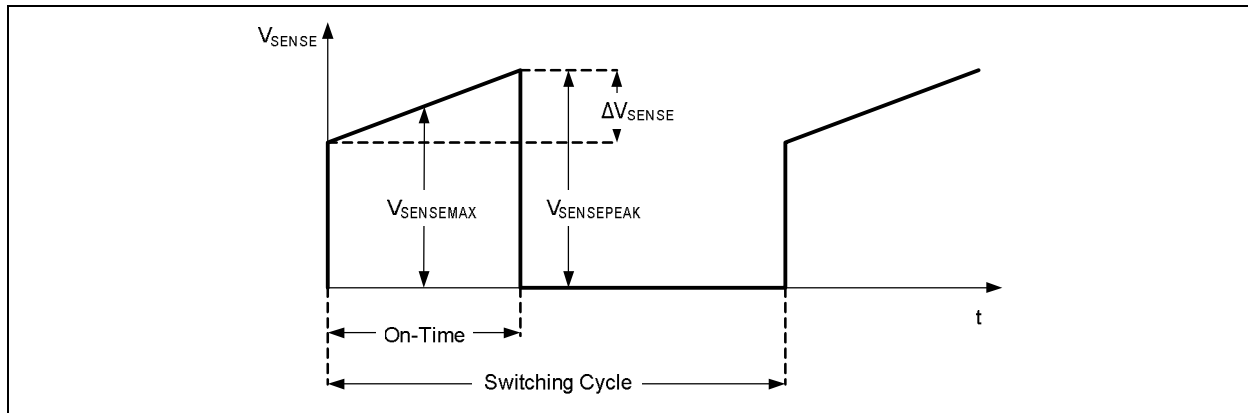

**Figure 10** Sense voltage  $V_{SENSE}$  waveform during a switching cycle

- $V_{SENSEMAX}$  = maximum average sense voltage at maximum output current  $I_{BO}$  measured during on-time
- $V_{SENSEPEAK}$  = maximum peak sense voltage at maximum output current  $I_{BO}$  at end of on-time
- $\Delta V_{SENSE}$  = ripple voltage across  $R_{CS}$  (switch ripple current) during on-time, represents the peak-to-peak ripple current in the boost inductor  $L_{BOOST}$

The maximum (peak-to-peak) switch current ripple percentage  $\chi$  (will be needed for further calculations of inductor values) can be calculated considering the 20% margin by **Equation (9.3)**:

$$\chi = \frac{\Delta V_{SENSE}}{0,80 \times V_{SWCS} - 0,50 \times \Delta V_{SENSE}} \quad (9.3)$$

- $V_{SWCS}$  = switch peak overcurrent threshold
- $\chi$  is recommended to be in the range of 0.2 to 0.6 (please refer to calculations in the following chapters)

The value of the sense resistor  $R_{CS}$  can be calculated as follows:

$$R_{CS} = \frac{0,80 \times V_{SWCS}}{I_{BOOSTPEAK}} \quad (9.4)$$

- $I_{BOOSTPEAK}$  = peak current through the boost inductor  $L_{BOOST}$  (is calculated at boost inductor selection)

**Boost inductor LBOOST selection**

The important parameters for selecting the boost inductor are:

- Inductor  $L_{BOOST}$
- Maximum RMS current rating  $I_{BOOSTRMS}$  for thermal design
- Saturation current threshold  $I_{BOOSTSAT}$

The maximum average inductor current is:

$$I_{BOOSTMAX} = I_{BOMAX} \times \frac{1}{1 - D_{MAX}} \quad (9.5)$$

The ripple current through the boost inductor is:

$$\Delta I_{BOOST} = \chi \times I_{BOOSTMAX} = \chi \times I_{BOMAX} \times \frac{1}{1 - D_{MAX}} \quad (9.6)$$

**Application information**

The peak current through the boost inductor is:

$$I_{\text{BOOSTPEAK}} = I_{\text{BOOSTMAX}} \times \left(1 + \frac{\chi}{2}\right) < I_{\text{BOOSTSAT}} \quad (9.7)$$

The peak current through the boost inductor must be below the saturation current threshold.

The RMS current through the boost inductor is:

$$I_{\text{BOOSTRMS}} = I_{\text{BOOSTMAX}} \times \sqrt{1 + \frac{\chi^2}{12}} \quad (9.8)$$

The boost inductor value  $L_{\text{BOOST}}$  can be calculated by [Equation \(9.9\)](#):

$$L_{\text{BOOST}} = \frac{V_{\text{INMIN}}}{\Delta I_{\text{BOOST}} \times f_{\text{FREQ}}} \times D_{\text{MAX}} \quad (9.9)$$

In fixed frequency mode an external resistor determines the switching frequency. The minimum boost inductor for fixed frequency is given [Equation \(9.10\)](#):

- $L_{\text{BOOSTMIN}}$  = minimum Inductance required (minimum value of  $L_{\text{BOOST}}$ )

$$L_{\text{BOOSTMIN}} \geq \frac{V_{\text{BO}}[\text{V}] \times R_{\text{CS}}[\Omega]}{106 \times 10^{-3} [\text{V}] \times f_{\text{FREQ}}[\text{Hz}]} \quad (9.10)$$

Following the equations above, the user should choose the boost inductor having sufficient saturation and RMS current ratings.

The boost inductor value influences the current ripple  $\Delta I_{\text{BOOST}}$ :

- A larger boost inductor value decreases the current ripple  $\Delta I_{\text{BOOST}}$ , but reduces also the current loop gain
- A lower boost inductor value increases the current ripple  $\Delta I_{\text{BOOST}}$ , but provides faster transient response. A lower boost inductor value also results in higher input current ripple and greater core losses.

**Output diode DBOOST selection**

Guidelines to choose the diode:

- Fast switching diode
- Low forward drop
- Low reverse leakage current
- Repetitive reverse voltage rating  $V_{\text{RRM}}$  (please refer to diode datasheet) is recommended to be at least 10 V above boost converter output voltage  $V_{\text{BO}}$

Average forward current in normal operation is equal to the boost converter output current  $I_{\text{BO}}$  and the peak current through the diode  $I_{\text{DPEAK}}$  (during off-time of the power MOSFET) is:

$$I_{\text{DPEAK}} = I_{\text{BOOSTPEAK}} = I_{\text{BOOSTMAX}} \times \left(1 + \frac{\chi}{2}\right) \quad (9.11)$$

Power dissipation  $P_{\text{LOSSDIO}}$  in the output diode  $D_{\text{BOOST}}$  is:

$$P_{\text{LOSSDIO}} = I_{\text{BOMAX}} \times V_{\text{D}} \quad (9.12)$$

- $V_{\text{D}}$  = forward drop voltage of diode  $D_{\text{BOOST}}$  (please refer to diode datasheet)

## Application information

### Output filter capacitor C<sub>OUT</sub> selection

Choosing the correct output capacitor for given output voltage ripple, consider the influence of:

- ESR = equivalent series resistance
- ESL = equivalent series inductance
- Bulk capacitance

These parameters can add ringing to the output voltage  $V_{BO}$ .

The voltage ripple at the output voltage  $V_{BO}$  depends on:

- $\Delta V_{ESR}$ : in percent, related to the ESR of the output capacitor(s)
- $\Delta V_{COUT}$ : in percent, related to the bulk capacitance of the output capacitor(s)
- For total voltage ripple, the influence of  $\Delta V_{ESR}$  and  $\Delta V_{COUT}$  must be considered together

The output capacitor can be calculated using **Equation (9.13)** (which contains the influence of the bulk capacitance on the output voltage ripple):

$$C_{OUT} \geq \frac{I_{BOMAX}}{\Delta V_{COUT} \times V_{OUT} \times f_{FREQ}} \quad (9.13)$$

Influence of the capacitor ESR on the output voltage ripple:

$$ESR_{COUT} \leq \frac{\Delta V_{ESR}}{I_{DPEAK}} \quad (9.14)$$

The output capacitor experiences high RMS ripple current. RMS ripple current rating can be determined using **Equation (9.15)**:

$$I_{COUTRMS} \geq I_{BOMAX} \times \sqrt{\frac{D_{MAX}}{1 - D_{MAX}}} \quad (9.15)$$

- $I_{COUTRMS}$  = RMS ripple current rating at switching frequency  $f_{FREQ}$

To meet ESR requirements multiple capacitors can be used in parallel. Typically, once the ESR requirement is met, the output capacitance is adequate for filtering and has the required RMS current rating. Additional ceramic capacitors are used to reduce the effects of parasitic inductance to reduce high frequency switching noise on the boost converter output.

### Input filter capacitor C<sub>IN1</sub> selection

The input filter capacitor  $C_{IN1}$  has to compensate alternating current content or current ripple on the input line. Recommended values are from 10 to 100  $\mu$ F. To improve suppression of high frequency distortion a ceramic capacitor in parallel might be necessary.

The RMS input capacitor ripple current  $I_{IN1RMS}$  for a boost converter is:

$$I_{IN1RMS} = 0,30 \times \Delta I_{BOOST} \quad (9.16)$$

## Application information

### Compensation network elements R<sub>COMP</sub>, C<sub>COMP</sub> selection

To compensate the feedback loop of the TLE8386-2EL a series network of  $R_{COMP}$ ,  $C_{COMP}$  is usually connected from COMP pin to ground. For most applications  $C_{COMP}$  should be in the range of 470 pF to 22 nF, and  $R_{COMP}$  should be in the range of 5 to 100 kΩ. An additional capacitor  $C_{COMP2}$  might be useful to improve stability.  $C_{COMP}$  and  $C_{COMP2}$  should be low ESR ceramic capacitors.

A practical approach to determine the compensation network is to start with the application circuit as shown in [Figure 8](#) and then tune the compensation network for optimizing performance. Stability of the loop should then be checked in any operating condition, including output current and variations and across the entire temperature range.

### Output boost voltage V<sub>BO</sub> adjustment by determining the output voltage resistor divider R<sub>FBH</sub>, R<sub>FBL</sub>

- $V_{FB}$  = feedback reference voltage

$$V_{BO} = V_{FB} \times \frac{R_{FBH} + R_{FBL}}{R_{FBL}} \quad (9.17)$$

( $V_{BO}$  is always higher than  $V_{IN}$  during operation of the boost converter)

### Additional input filter inductor L<sub>INPUT</sub> and capacitor C<sub>IN2</sub> selection

- $f_{FILTER}$  = resonance frequency of the additional input filter

The input filter inductor  $L_{INPUT}$  should have a saturation current value equal to  $I_{BOOST}$ . Capacitor  $C_{IN2}$  should be a low ESR ceramic capacitor. Both components form a low pass filter for suppressing conducted disturbance on the  $V_{IN}$  line. To obtain optimum suppression, the input filter resonance frequency  $f_{FILTER}$  should be at least ten times lower than the switching frequency  $f_{FREQ}$ :

$$f_{FREQ} > 10 \times \left( f_{FILTER} = \frac{1}{2\pi \sqrt{L_{INPUT} \times C_{IN2}}} \right) \quad (9.18)$$

The use of an additional input filter is depending on the requirements of the application.

For selecting  $R_{FREQ}$ ,  $C_{SST}$  and  $C_{IVCC}$  please refer to previous chapters.

## 9.2 Further information on TLE8386-2EL

### 9.2.1 General layout recommendations

#### Introduction

A boost converter is a potential source of electromagnetic disturbances which may affect environment as well as the device itself and cause sporadic malfunction or damage depending on the amount of noise.

Basic effects which should be considered:

- Radiated magnetic fields caused by circular current, occurring mostly at switching frequency and its harmonics
- Radiated electric fields, often caused by voltage oscillation
- Conducted disturbance (voltage spikes or oscillation) on the lines, mostly on input and output lines

## Application information

### Radiated magnetic fields

Radiated magnetic fields are caused by circular current occurring in current windows. A current window is the area, which is defined by circular current paths. Circular current is alternating current driven by the switching transistor. Alternating current in current windows drive magnetic fields. The amount of magnetic emissions depends on the amplitude of the alternating current and on the area of the current window.

Current windows:

- Input current window:  
Path consisting of  $C_{IN1}$ ,  $L_{BOOST}$  and the power MOSFET - only the alternating current component of the input current  $I_{IN}$  is considered
- Output current window:  
Path consisting of the power MOSFET,  $D_{BOOST}$  and  $C_{OUT}$  - output current ripple  $\Delta I$

These current windows have to be kept as small as possible, with the relating components placed next to each other. It is highly recommended to use a ground plane as a single layer which covers the complete regulator area with all components. All connections to ground should be as short as possible.

### Radiated electric fields

Radiated electric fields are caused by voltage oscillation due to stray inductances and stray capacitances at the connection between power MOSFET, output diode  $D_{BOOST}$  and output capacitor  $C_{OUT}$ . They are also influenced by the commutation of the current from the power MOSFET to the output diode  $D_{BOOST}$ . The frequency range of radiated electric fields might be between 10 MHz and 100 MHz. Therefore it is recommended to use a fast Schottky diode and to keep connections in this area as low inductive as possible. This can be achieved by using short and broad connections and to arrange the related parts as close as possible to each other. Using a ground layer these low inductive connections form a small capacitances with the ground layer. This capacitance damps the slope of these oscillations. Oscillations use connections or wires as antennas. This effect can be minimized by using short and broad connections.

### Conducted disturbances

Conducted disturbances are voltage spikes or voltage oscillation, occurring permanently or by occasion mostly on the input or output connections. Like radiated electric fields they are caused by voltage oscillation diode  $D_{BOOST}$  and output capacitor  $C_{OUT}$ .

The frequency range of conducted disturbance might be between 10 MHz and 100 MHz. Conducted disturbance is superimposed to input voltage and output voltage and might disturb other components of the application.

Countermeasures against conducted disturbances are similar to the countermeasures against radiated electric fields:

- It is recommended to use short and broad connections between parts of the converter circuit
- All parts shall be mounted close to each other
- Additional filtering capacitors (ceramic, with low ESR) in parallel to the output and an input capacitor and as close as possible to the switching parts. Input and load current must be forced to pass these devices. Do not connect them via thin lines. Recommended values are 10 nF to 220 nF.
- A  $\Pi$ -filter for maximum suppression at input might be necessary, which requires additional capacitors at the input

**Application information**

**9.2.2 Additional information**

Please contact <http://www.infineon.com/>

- For further information, especially regarding the FMEA pin
- For application notes with more detailed information on this device



**Package information**

**10 Package information**

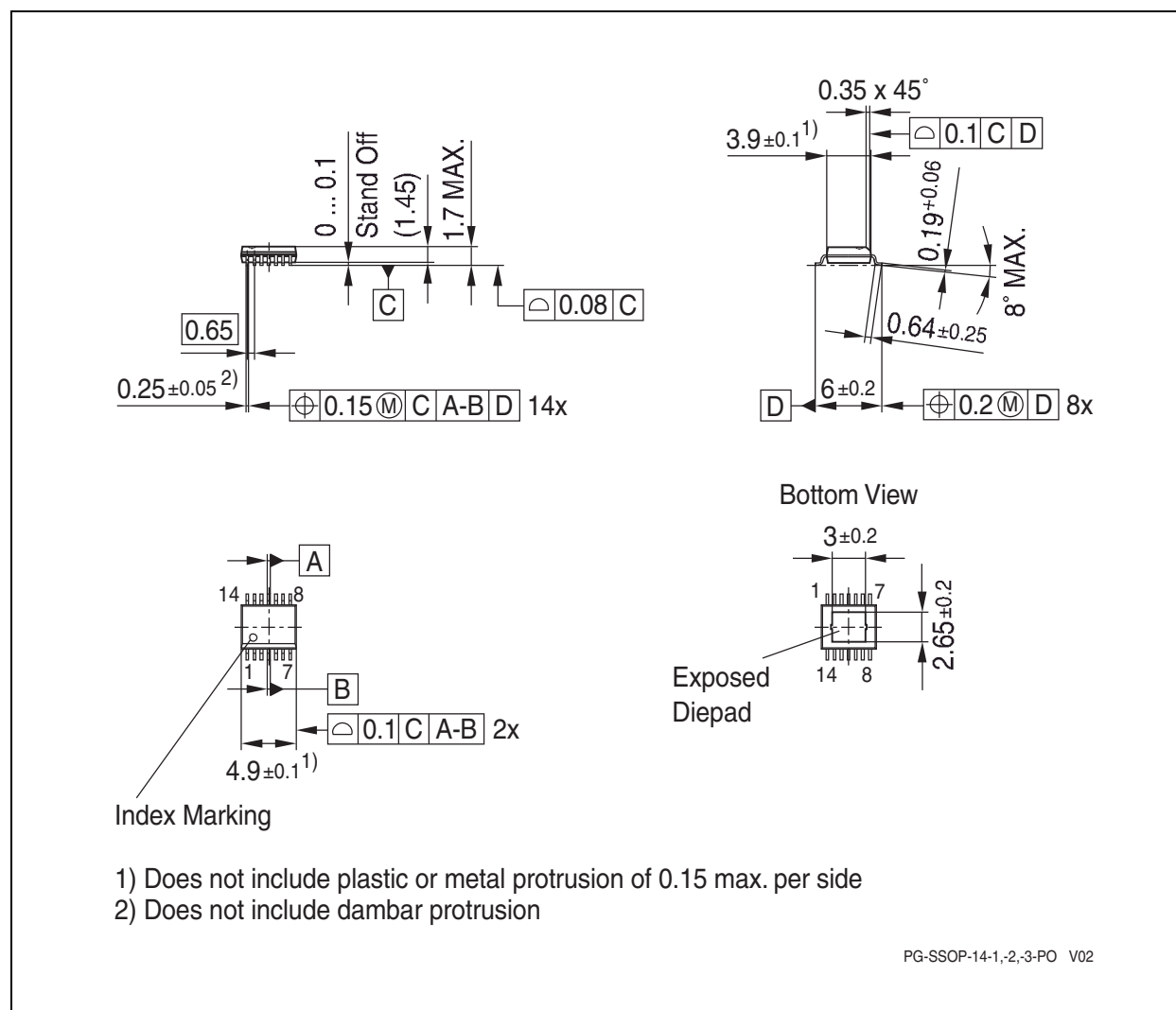

**Figure 11 PG-SSOP-14<sup>1)</sup>**

**Green Product (RoHS compliant)**

To meet the world-wide customer requirements for environmentally friendly products and to be compliant with government regulations the device is available as a green product. Green products are RoHS-Compliant (i.e Pb-free finish on leads and suitable for Pb-free soldering according to IPC/JEDEC J-STD-020).

**Further information on packages**

<https://www.infineon.com/packages>

1) Dimensions in mm

**Revision history**

## **11 Revision history**

<b>Revision</b>	<b>Date</b>	<b>Changes</b>
1.01	2021-12-03	Editorial changes Typo corrected: marking on device
1.0	2010-10-25	Initial release of datasheet

#### Trademarks

All referenced product or service names and trademarks are the property of their respective owners.

**Edition 2021-12-03**

**Published by  
Infineon Technologies AG  
81726 Munich, Germany**

**© 2021 Infineon Technologies AG.  
All Rights Reserved.**

**Do you have a question about any  
aspect of this document?  
Email: [erratum@infineon.com](mailto:erratum@infineon.com)**

**Document reference  
Z8F50012433**

#### IMPORTANT NOTICE

The information given in this document shall in no event be regarded as a guarantee of conditions or characteristics ("Beschaffheitsgarantie").

With respect to any examples, hints or any typical values stated herein and/or any information regarding the application of the product, Infineon Technologies hereby disclaims any and all warranties and liabilities of any kind, including without limitation warranties of non-infringement of intellectual property rights of any third party.

In addition, any information given in this document is subject to customer's compliance with its obligations stated in this document and any applicable legal requirements, norms and standards concerning customer's products and any use of the product of Infineon Technologies in customer's applications.

The data contained in this document is exclusively intended for technically trained staff. It is the responsibility of customer's technical departments to evaluate the suitability of the product for the intended application and the completeness of the product information given in this document with respect to such application.

For further information on technology, delivery terms and conditions and prices, please contact the nearest Infineon Technologies Office ([www.infineon.com](http://www.infineon.com)).

#### WARNINGS

Due to technical requirements products may contain dangerous substances. For information on the types in question please contact your nearest Infineon Technologies office.

Except as otherwise explicitly approved by Infineon Technologies in a written document signed by authorized representatives of Infineon Technologies, Infineon Technologies' products may not be used in any applications where a failure of the product or any consequences of the use thereof can reasonably be expected to result in personal injury.

# Datasheet update for product TLE8386-2EL

Customer Information Package  
IN 090/21



restricted

## Agenda

---

1	Motivation of the change	3
2	Change overview	5
3	Change details	7
4	Conclusion	11

## Agenda

---

1	Motivation of the change	3
2	Change overview	5
3	Change details	7
4	Conclusion	11

## Motivation of the change

---

- › Updates of datasheet
  - Corrected description of package marking
  - Updated datasheet layout

## Agenda

---

1	Motivation of the change	3
2	Change overview	5
3	Change details	7
4	Conclusion	11



## Change overview

---

Description	Old	New
Datasheet	Rev. 1.0	Rev. 1.01

## Agenda

---

1	Motivation of the change	3
2	Change overview	5
3	Change details	7
4	Conclusion	11

## Datasheet update: Corrected description of package marking

### Old

#### Rev. 1.0 (page 3)

Type	Package	Marking
TLE8386-2EL	PG-SSOP-14	TLE8386-2EL

#### Existing package marking

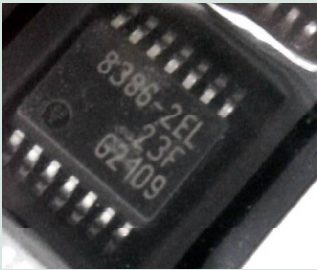

### New

#### Rev. 1.01 (page 2)

Type	Package	Marking
TLE8386-2EL	PG-SSOP-14	8386-2EL

#### Package marking - unchanged

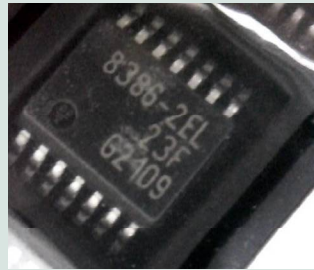

- › Correction of typo error, with no effect on functional behavior.
- › Actual marking on product packages does not change.

## Agenda

---

1	Motivation of the change	3
2	Change overview	5
3	Change details	7
4	Conclusion	11

## Conclusion

---

- › Datasheet update due to typo only, to document the actual marking on delivered packages
- › Actual marking on product packages does not change
- › No change in form/fit/function



Part of your life. Part of tomorrow.



**Information note N°090/21**

Data sheet update for product TLE8386-2EL

<b>Sales name</b>	<b>SP number</b>	<b>OPN</b>	<b>Package</b>
TLE8386-2EL	SP000685670	TLE83862ELXUMA1	PG-SSOP-14-3