



## Product Change Notification / SYST-04KTNM237

---

### Date:

05-Jan-2022

### Product Category:

CPU / System Supervisors, Power Management - System Supervisors/Voltage Detectors

### PCN Type:

Document Change

### Notification Subject:

Data Sheet - TC1270A/TC1270AN/TC1271A Voltage Supervisor with Manual Reset Input Data Sheet

### Affected CPNs:

[SYST-04KTNM237\\_Affected\\_CPN\\_01052022.pdf](#)

[SYST-04KTNM237\\_Affected\\_CPN\\_01052022.csv](#)

### Notification Text:

SYST-04KTNM237

Microchip has released a new Product Documents for the TC1270A/TC1270AN/TC1271A Voltage Supervisor with Manual Reset Input Data Sheet of devices. If you are using one of these devices please read the document located at [TC1270A/TC1270AN/TC1271A Voltage Supervisor with Manual Reset Input Data Sheet](#).

**Notification Status:** Final

**Description of Change:** 1. Updated Ground function pins in Table 3-1.  
2. Updated document layout.  
3. Minor corrections throughout.  
4. Updated available variants lists in Section 9.0 "Packaging information".  
5. Updated Product Identification System to include Automotive information.

**Impacts to Data Sheet:** See above details

**Reason for Change:** To Improve Productivity

**Change Implementation Status:** Complete

**Date Document Changes Effective:** 05 January 2022

**NOTE:** Please be advised that this is a change to the document only the product has not been changed.

**Markings to Distinguish Revised from Unrevised Devices:** N/A

## **Attachments:**

[TC1270A/TC1270AN/TC1271A Voltage Supervisor with Manual Reset Input Data Sheet](#)

Please contact your local [Microchip sales office](#) with questions or concerns regarding this notification.

## **Terms and Conditions:**

If you wish to receive Microchip PCNs via email please register for our PCN email service at our [PCN home page](#) select register then fill in the required fields. You will find instructions about registering for Microchips PCN email service in the [PCN FAQ](#) section.

If you wish to change your PCN profile, including opt out, please go to the [PCN home page](#) select login and sign into your myMicrochip account. Select a profile option from the left navigation bar and make the applicable selections.

Affected Catalog Part Numbers (CPN)

TC1270ALAVCTTR  
TC1270ALAVRCTR  
TC1270ALBVCTTR  
TC1270ALBVRCTR  
TC1270ALVCTTR  
TC1270ALVRCTR  
TC1270AMAVCTTR  
TC1270AMAVRCTR  
TC1270AMBVCTTR  
TC1270AMBVCTTR-V02  
TC1270AMBVCTTR-VAO  
TC1270AMBVRCTR  
TC1270AMVCTTR  
TC1270AMVRCTR  
TC1270ANLAVCTTR  
TC1270ANLAVRCTR  
TC1270ANLBVCTTR  
TC1270ANLBVRCTR  
TC1270ANLVCTTR  
TC1270ANLVRCTR  
TC1270ANMAVCTTR  
TC1270ANMAVCTTR-V02  
TC1270ANMAVRCTR  
TC1270ANMBVCTTR  
TC1270ANMBVRCTR  
TC1270ANMVCTTR  
TC1270ANMVRCTR  
TC1270ANRAVCTTR  
TC1270ANRAVRCTR  
TC1270ANRBVCTTR  
TC1270ANRBVRCTR  
TC1270ANRVCTTR  
TC1270ANRVRCTR  
TC1270ANSAVCTTR  
TC1270ANSAVRCTR  
TC1270ANSBVCTTR  
TC1270ANSBVCTTR-V01  
TC1270ANSBVCTTR-VAO  
TC1270ANSBVRCTR  
TC1270ANSVCTTR  
TC1270ANSVRCTR  
TC1270ANTAVCTTR  
TC1270ANTAVRCTR  
TC1270ANTBVCTTR  
TC1270ANTBVRCTR  
TC1270ANTVCTTR

TC1270ANTVRCTR  
TC1270ARAVCTTR  
TC1270ARAVRCTR  
TC1270ARBVCTTR  
TC1270ARBVRCTR  
TC1270ARVCTTR  
TC1270ARVRCTR  
TC1270ARVRCTR-VAO  
TC1270ARVRCTRAAA  
TC1270ASAVCTTR  
TC1270ASAVRCTR  
TC1270ASBVCTTR  
TC1270ASBVCTTRVAO  
TC1270ASBVRCTR  
TC1270ASVCTTR  
TC1270ASVRCTR  
TC1270ATAVCTTR  
TC1270ATAVCTTR-V01  
TC1270ATAVRCTR  
TC1270ATBVCTTR  
TC1270ATBVRCTR  
TC1270ATVCTTR  
TC1270ATVRCTR  
TC1271ALAVCTTR  
TC1271ALAVRCTR  
TC1271ALBVCTTR  
TC1271ALBVRCTR  
TC1271ALVCTTR  
TC1271ALVRCTR  
TC1271AMAVCTTR  
TC1271AMAVRCTR  
TC1271AMBVCTTR  
TC1271AMBVRCTR  
TC1271AMVCTTR  
TC1271AMVRCTR  
TC1271ARAVCTTR  
TC1271ARAVRCTR  
TC1271ARBVCTTR  
TC1271ARBVRCTR  
TC1271ARVCTTR  
TC1271ARVRCTR  
TC1271ASAVCTTR  
TC1271ASAVRCTR  
TC1271ASBVCTTR  
TC1271ASBVRCTR  
TC1271ASVCTTR  
TC1271ASVRCTR  
TC1271ATAVCTTR  
TC1271ATAVRCTR

TC1271ATBVCTTR  
TC1271ATBVRCTR  
TC1271ATVCTTR  
TC1271ATVRCTR

## Voltage Supervisor with Manual Reset Input

### Features

- Precision Voltage Monitor
  - 2.63V, 2.93V, 3.08V, 4.38V and 4.63V Trip Points (Typical)
- Manual Reset Input
- Reset Time-Out Delay:
  - Standard: 280 ms (Typical)
  - Optional: 2.19 ms, and 35 ms (Typical)
- Power Consumption  $\leq 15 \mu\text{A}$  max
- No glitches on outputs during power-up
- Active Low Output Options:
  - Push-Pull Output and Open-Drain Output
- Active High Output Option:
  - Push-Pull Output
- Replacement for (Specification compatible with):
  - TC1270, TC1271
  - TCM811, TCM812
- Fully Static Design
- Low-Voltage Operation (1.0V)
- ESD Protection:
  - $\geq 4$  kV Human Body Model (HBM)
  - $\geq 400$ V Machine Model (MM)
- Extended (E) Temperature Range:
  - $-40^{\circ}\text{C}$  to  $+125^{\circ}\text{C}$
- Package Options:
  - 4-Lead SOT-143
  - 5-Lead SOT-23
  - Pb-free Device
- Passes Automotive AEC-Q100 Reliability Testing

### Package Types

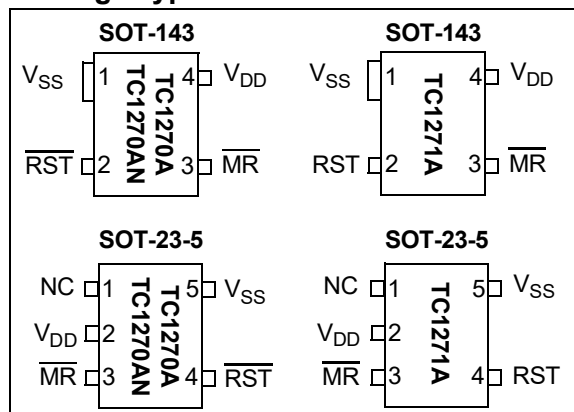

### Functional Block Diagram

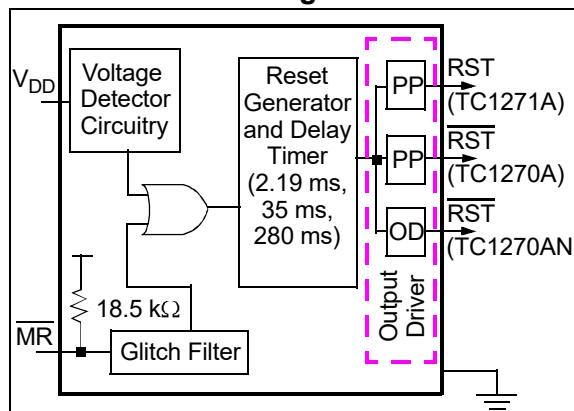

### Device Features

Device	Output		Reset Delay (ms) (Typ) <sup>(3)</sup>	Reset Trip Point (V) <sup>(3)</sup>	Voltage Range (V)	Temperature Range	Packages	Comment
	Type	Active Level						
TC1270A	Push-Pull	Low	2.19, 35, 280 <sup>(1)</sup>	4.63, 4.38, 3.08, 2.93, 2.63 <sup>(4)</sup>	1.0V to 5.5V	$-40^{\circ}\text{C}$ to $+125^{\circ}\text{C}$	SOT-143 <sup>(2)</sup> , SOT-23-5	Replaces TC1270 and TCM811
TC1270AN	Open-Drain	Low					SOT-143 <sup>(2)</sup> , SOT-23-5	New Option
TC1271A	Push-Pull	High					SOT-143 <sup>(2)</sup> , SOT-23-5	Replaces TC1271 and TCM812

- Note**
- The 280 ms Reset delay time-out is compatible with the TC1270, TC1271, TCM811 and TCM812 devices.
  - The SOT-143 package is compatible with the TC1270, TC1271, TCM811 and TCM812 devices.
  - Custom Reset trip points and Reset delays available, contact your local Microchip sales office.
  - The TC1270/1 and TCM811/12 1.75V trip point option is not supported.

# TC1270A/70AN/71A

## 1.0 ELECTRICAL CHARACTERISTICS

### Absolute Maximum Ratings<sup>(†)</sup>

Supply Voltage ( $V_{DD}$ to $V_{SS}$ )	+7.0V
Input Current, $V_{DD}$	10 mA
Output Current, $\overline{\text{RESET}}$ , Reset	10 mA
Voltage on all inputs and outputs w.r.t. $V_{SS}$	-0.6V to ( $V_{DD} + 1.0V$ )
Storage Temperature Range	-65°C to +150°C
Operating Temperature Range	-40°C to +125°C
Maximum Junction Temperature, $T_J$	150°C
ESD protection on all pins	
Human Body Model	≥ 4 kV
Machine Model	≥ 400V

† **Notice:** Stresses above those listed under “Absolute Maximum Ratings” may cause permanent damage to a device. The absolute maximum values are merely stress ratings – functional operation of a device at those, or any other conditions above those indicated in the operational listing of these specifications, is not implied. Exposure to absolute maximum rating conditions for extended periods may affect device reliability.

## ELECTRICAL CHARACTERISTICS

**Electrical Characteristics:** Unless otherwise noted,  $V_{DD} = 5V$  for L/M versions,  $V_{DD} = 3.3V$  for T/S versions,  $V_{DD} = 3V$  for R version,  $T_A = -40^\circ\text{C}$  to  $+125^\circ\text{C}$ . Typical values are at  $T_A = +25^\circ\text{C}$ .

Parameter	Sym.	Min.	Typ. <sup>(1)</sup>	Max.	Units	Test Conditions
Operating Voltage Range	$V_{DD}$	1.0	—	5.5	V	
Supply Current	$I_{DD}$	—	7	15	$\mu\text{A}$	$V_{DD} > V_{TRIP}$ , for L/M/R/S/T, $V_{DD} = 5.5V$
		—	4.75	10	$\mu\text{A}$	$V_{DD} > V_{TRIP}$ , for R/S/T, $V_{DD} = 3.6V$
		—	10	15	$\mu\text{A}$	$V_{DD} < V_{TRIP}$ , for L/M/R/S/T
Reset Trip Point Threshold <sup>(3)</sup>	$V_{TRIP}$	4.54	4.63	4.72	V	TC127xAL: $T_A = +25^\circ\text{C}$
		4.50	—	4.75	V	$T_A = -40^\circ\text{C}$ to $+125^\circ\text{C}$
		4.30	4.38	4.46	V	TC127xAM: $T_A = +25^\circ\text{C}$
		4.25	—	4.50	V	$T_A = -40^\circ\text{C}$ to $+125^\circ\text{C}$
		3.03	3.08	3.14	V	TC127xAT: $T_A = +25^\circ\text{C}$
		3.00	—	3.15	V	$T_A = -40^\circ\text{C}$ to $+125^\circ\text{C}$
		2.88	2.93	2.98	V	TC127xAS: $T_A = +25^\circ\text{C}$
		2.85	—	3.00	V	$T_A = -40^\circ\text{C}$ to $+125^\circ\text{C}$
		2.72	2.77	2.82	V	TC127xA: <sup>(5)</sup> $T_A = +25^\circ\text{C}$
		2.70	—	2.85	V	$T_A = -40^\circ\text{C}$ to $+125^\circ\text{C}$
		2.58	2.63	2.68	V	TC127xAR: $T_A = +25^\circ\text{C}$
		2.55	—	2.70	V	$T_A = -40^\circ\text{C}$ to $+125^\circ\text{C}$

**Note 1:** Data in the Typical (“Typ.”) column is at 5V, +25°C, unless otherwise stated.

**Note 2:**  $\overline{\text{RST}}$  output for TC1270A and TC1270AN, RST output for TC1271A.

**Note 3:** TC127XA refers to the TC1270A, TC1270AN or TC1271A device.

**Note 4:** Hysteresis is within the  $V_{TRIP(MIN)}$  to  $V_{TRIP(MAX)}$  window.

**Note 5:** Custom-ordered voltage trip point. Minimum order volume requirement.

**Note 6:** This specification allows this device to be used in PIC<sup>®</sup> microcontroller applications that require the In-Circuit Serial Programming<sup>™</sup> (ICSP<sup>™</sup>) feature (see device-specific programming specifications for voltage requirements). The total time that the RST pin can be above the maximum device operational voltage (5.5V) is 100s. Current into the RST pin should be limited to 2 mA. It is recommended that the device operational temperature be maintained between 0°C to +70°C (+25°C preferred). For additional information, refer to [Figure 2-41](#).

# TC1270A/70AN/71A

## ELECTRICAL CHARACTERISTICS (CONTINUED)

**Electrical Characteristics:** Unless otherwise noted,  $V_{DD} = 5V$  for L/M versions,  $V_{DD} = 3.3V$  for T/S versions,  $V_{DD} = 3V$  for R version,  $T_A = -40^{\circ}C$  to  $+125^{\circ}C$ . Typical values are at  $T_A = +25^{\circ}C$ .

Parameter	Sym.	Min.	Typ. <sup>(1)</sup>	Max.	Units	Test Conditions	
Reset Threshold Tempco		—	±30	—	ppm/°C		
Reset Trip Point Hysteresis <sup>(1)</sup>	$V_{HYS}$	—	0.3	—	%	Percentage of $V_{TRIP}$ Voltage	
MR Input High Threshold	$V_{IH}$	2.3	—	—	V	$V_{DD} > V_{TRIP(MAX)}$ , L/M only	
		$0.7 V_{DD}$	—	—	V	$V_{DD} > V_{TRIP(MAX)}$ , R/S/T only	
MR Input Low Threshold	$V_{IL}$	—	—	0.8	V	$V_{DD} > V_{TRIP(MAX)}$ , L/M only	
		—	—	$0.25 V_{DD}$	V	$V_{DD} > V_{TRIP(MAX)}$ , R/S/T only	
MR Pull-up Resistance		10	18.5	40	kΩ		
Open-Drain High Voltage on Output	$V_{ODH}$	—	—	13.5	V	Open-Drain Output pin only. $V_{DD} = 3.0V$ , Time voltage > 5.5 applied ≤ 100s. Current into pin limited to 2 mA +25°C operation recommended <sup>(6)</sup>	
Reset Output Voltage Low <sup>(2)</sup>	TC1270A/TC1270AN	$V_{OL}$	—	—	0.3	V	R/S/T only, $I_{SINK} = 1.2 mA$ , $V_{DD} = V_{TRIP(MIN)}$
	TC1271A		—	—	0.3	V	R/S/T only, $I_{SINK} = 1.2 mA$ , $V_{DD} = V_{TRIP(MAX)}$
	TC1270A/TC1270AN		—	—	0.4	V	L/M only, $I_{SINK} = 3.2 mA$ , $V_{DD} = V_{TRIP(MIN)}$
	TC1271A		—	—	0.3	V	L/M only, $I_{SINK} = 3.2 mA$ , $V_{DD} = V_{TRIP(MAX)}$
	TC1270A/TC1270AN		—	—	0.3	V	L/M only, $I_{SINK} = 50 \mu A$ , $V_{DD} > 1.0V$
Reset Output Voltage High <sup>(2)</sup>	TC1270A	$V_{OH}$	$0.8 V_{DD}$	—	—	V	R/S/T only, $I_{SOURCE} = 500 \mu A$ , $V_{DD} = V_{TRIP(MAX)}$
	TC1270A		$V_{DD} - 1.5$	—	—	V	L/M only, $I_{SOURCE} = 800 \mu A$ , $V_{DD} = V_{TRIP(MAX)}$
	TC1271A		$0.8 V_{DD}$	—	—	V	$I_{SOURCE} = 500 \mu A$ , $V_{DD} \leq V_{TRIP(MIN)}$
Input Leakage Current	$I_{IL}$	—	—	±1	μA	$V_{PIN} = V_{DD}$	
Open-Drain RST Output Leakage	$I_{OLOD}$	—	—	1	μA	Open-Drain configuration only.	
Capacitive Loading Specification on Output Pins	$C_{IO}$	—	—	50	pF		

**Note 1:** Data in the Typical ("Typ.") column is at 5V, +25°C, unless otherwise stated.

**2:** RST output for TC1270A and TC1270AN, RST output for TC1271A.

**3:** TC127XA refers to the TC1270A, TC1270AN or TC1271A device.

**4:** Hysteresis is within the  $V_{TRIP(MIN)}$  to  $V_{TRIP(MAX)}$  window.

**5:** Custom-ordered voltage trip point. Minimum order volume requirement.

**6:** This specification allows this device to be used in PIC<sup>®</sup> microcontroller applications that require the In-Circuit Serial Programming™ (ICSP™) feature (see device-specific programming specifications for voltage requirements). The total time that the RST pin can be above the maximum device operational voltage (5.5V) is 100s. Current into the RST pin should be limited to 2 mA. It is recommended that the device operational temperature be maintained between 0°C to +70°C (+25°C preferred). For additional information, refer to [Figure 2-41](#).



# TC1270A/70AN/71A

## 1.1 AC CHARACTERISTICS

### 1.1.1 TIMING PARAMETER SYMBOLOGY

The timing parameter symbols have been created following one of the next formats:

1. TppS2ppS

2. TppS

T		T	
F	Frequency	T	Time
E	Error		

Lowercase letters (pp) and their meanings:

pp			
io	Input or Output pin	osc	Oscillator
rx	Receive	tx	Transmit
bitclk	RX/TX BITCLK	RST	Reset
drt	Device Reset Timer		

Uppercase letters and their meanings:

S			
F	Fall	P	Period
H	High	R	Rise
I	Invalid (High-impedance)	V	Valid
L	Low	Z	High-impedance

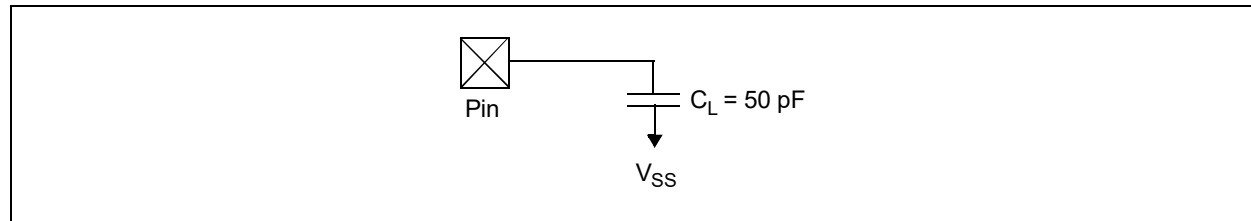

**FIGURE 1-1:** Test Load Conditions.

## TIMING DIAGRAMS AND SPECIFICATIONS

### MR Pin and Reset Pin Waveform

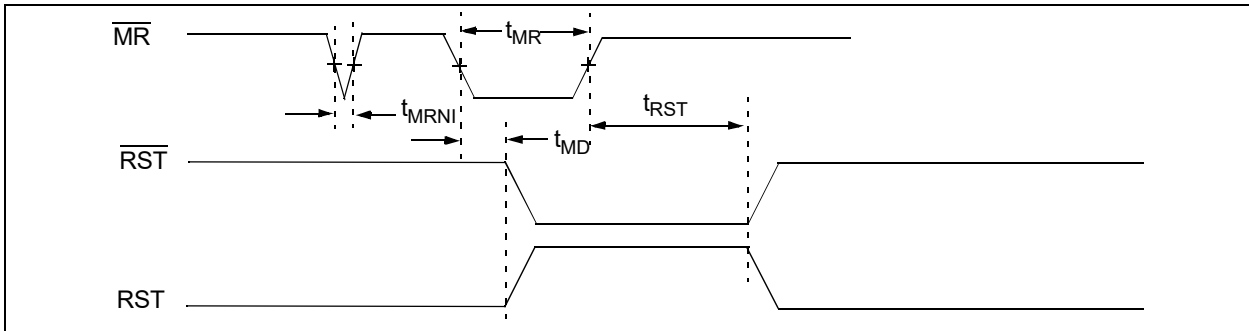

### Device Voltage and Reset Pin (Active Low) Waveform

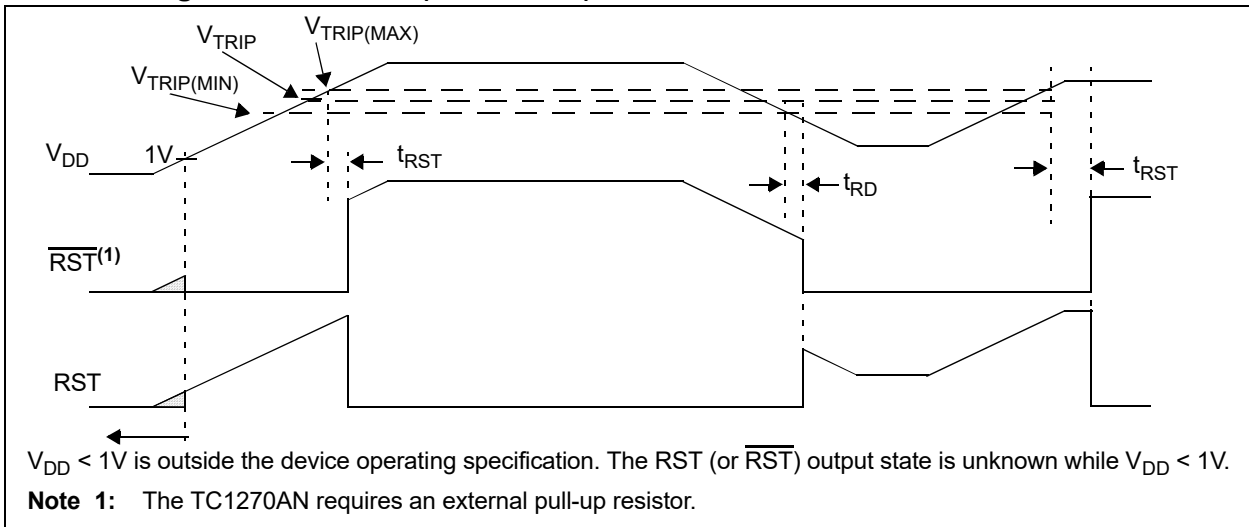

### Reset and Device Reset Timer Requirements

**Electrical Characteristics:** Unless otherwise noted,  $V_{DD} = 5V$  for L/M versions,  $V_{DD} = 3.3V$  for T/S versions,  $V_{DD} = 3V$  for R version,  $T_A = -40^\circ C$  to  $+125^\circ C$ . Typical values are at  $T_A = +25^\circ C$ .

Parameter	Sym	Min	Typ <sup>(1)</sup>	Max	Units	Test Conditions
$V_{DD}$ to Reset Delay	$t_{RD}$	—	50	—	$\mu s$	$V_{DD} = V_{TRIP(MAX)}$ to $V_{TRIP(MIN)} - 125 mV$
Reset Active Time Out Period	TC127XAxBVyy <sup>(3)</sup>	1.09	2.19	4.38	ms	$V_{DD} = V_{TRIP(MAX)}$
	TC127XAxAVyy <sup>(3)</sup>	17.5	35	70	ms	$V_{DD} = V_{TRIP(MAX)}$
	TC127XAxVyy <sup>(3)</sup>	140	280	560	ms	$V_{DD} = V_{TRIP(MAX)}$
$\overline{MR}$ Minimum Pulse Width	$t_{MR}$	10	—	—	$\mu s$	
$\overline{MR}$ Noise Immunity	$t_{MRNI}$	—	0.1	—	$\mu s$	
$\overline{MR}$ to Reset Propagation Delay	$t_{MD}$	—	0.2	—	$\mu s$	

**Note 1:** Unless otherwise stated, data in the Typical ("Typ") column is at 5V,  $+25^\circ C$ .

**2:**  $\overline{RST}$  output for TC1270A, RST output for TC1271A.

**3:** TC127XA refers to the TC1270A, TC1270AN or TC1271A device.

"x" indicates the selected voltage trip point, while "yy" indicates the package code.

# TC1270A/70AN/71A

---

---

## TEMPERATURE CHARACTERISTICS

**Electrical Specifications:** Unless otherwise indicated,  $V_{DD} = +1.0V$  to  $+5.5V$ ,  $V_{SS} = GND$ .

Parameters	Sym	Min	Typ	Max	Units	Conditions
<b>Temperature Ranges</b>						
Maximum Junction Temperature Range	$T_J$	-40	—	+150	°C	
Operating Temperature Range	$T_A$	-40	—	+125	°C	
Storage Temperature Range	$T_S$	-65	—	+150	°C	
<b>Thermal Package Resistances</b>						
Thermal Resistance, 5L-SOT-23	$\theta_{JA}$	—	256	—	°C/W	
Thermal Resistance, 4L-SOT-143	$\theta_{JA}$	—	426	—	°C/W	

## 2.0 TYPICAL PERFORMANCE CURVES

**Note:** The graphs and tables that follow this note are the result of a statistical summary based on a limited number of samples and are provided for informational purposes only. The performance characteristics listed herein are not tested or guaranteed. In some graphs or tables, the data presented may be outside the specified operating range (e.g., outside specified power supply range) and therefore outside the warranted range.

**Note:** Unless otherwise indicated, all limits are specified for  $V_{DD} = 1V$  to  $5.5V$ ,  $T_A = -40^{\circ}C$  to  $+125^{\circ}C$ .

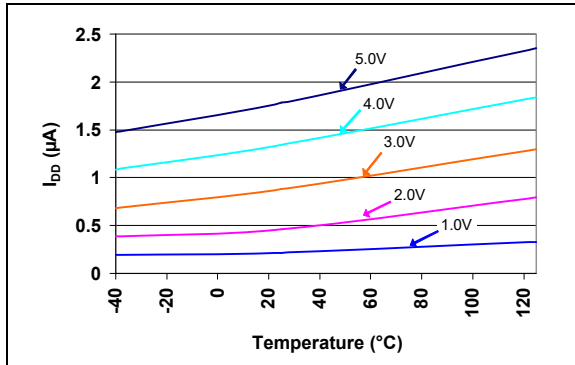

**FIGURE 2-1:**  $I_{DD}$  vs. Temperature (Reset Power-up Timer Inactive)  
(TC1270AL, TC1270ANL, TC1271AL  
- 4.50V min./4.63V typ./4.75V max.).

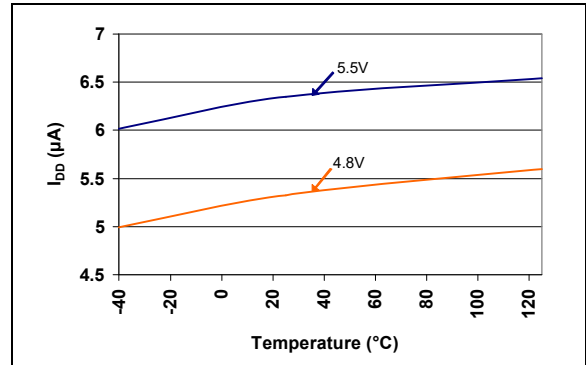

**FIGURE 2-4:**  $I_{DD}$  vs. Temperature (Reset Power-up Timer Active)  
(TC1270AL, TC1270ANL, TC1271AL  
- 4.50V min./4.63V typ./4.75V max.).

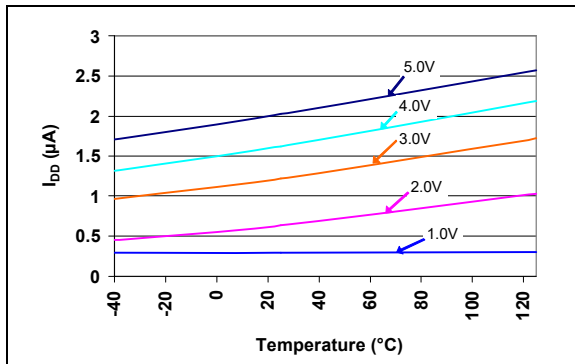

**FIGURE 2-2:**  $I_{DD}$  vs. Temperature (Reset Power-up Timer Inactive)  
(TC1270AT, TC1270ANT, TC1271AT  
- 3.00V min./3.08V typ./3.15V max.).

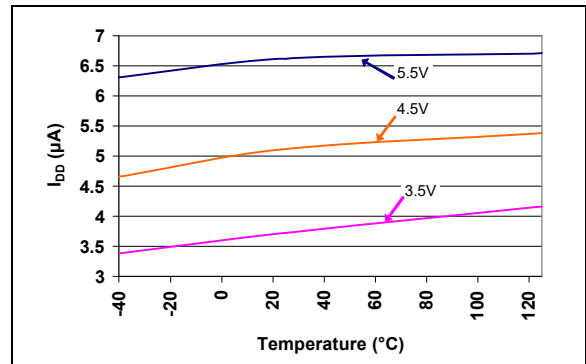

**FIGURE 2-5:**  $I_{DD}$  vs. Temperature (Reset Power-up Timer Active)  
(TC1270AT, TC1270ANT, TC1271AT  
- 3.00V min./3.08V typ./3.15V max.).

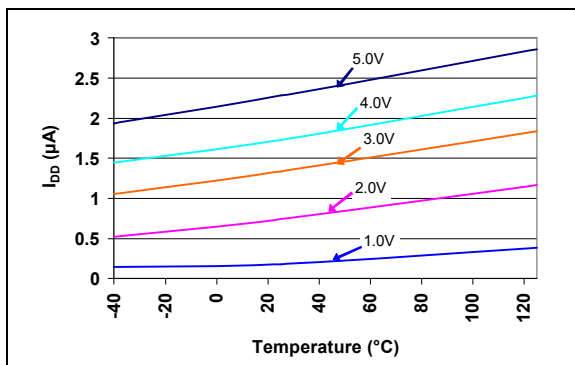

**FIGURE 2-3:**  $I_{DD}$  vs. Temperature (Reset Power-up Timer Inactive)  
(TC1270AR, TC1270ANR, TC1271AR  
- 2.55V min./2.63V typ./2.70V max.).

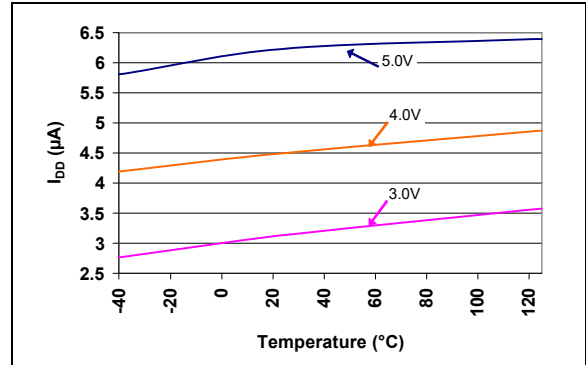

**FIGURE 2-6:**  $I_{DD}$  vs. Temperature (Reset Power-up Timer Active)  
(TC1270AR, TC1270ANR, TC1271AR  
- 2.55V min./2.63V typ./2.70V max.).

# TC1270A/70AN/71A

**Note:** Unless otherwise indicated, all limits are specified for  $V_{DD} = 1V$  to  $5.5V$ ,  $T_A = -40^{\circ}C$  to  $+125^{\circ}C$ .

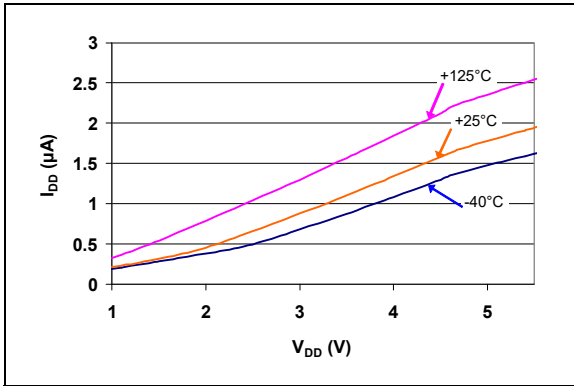

**FIGURE 2-7:**  $I_{DD}$  vs.  $V_{DD}$  (Reset Power-up Timer Inactive)  
(TC1270AL, TC1270ANL, TC1271AL  
- 4.50V min./4.63V typ./4.75V max.).

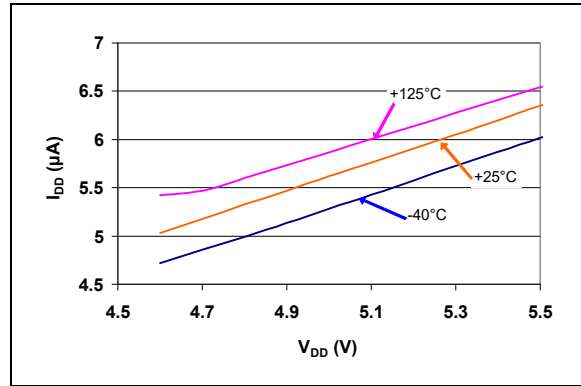

**FIGURE 2-10:**  $I_{DD}$  vs.  $V_{DD}$  (Reset Power-up Timer Active)  
(TC1270AL, TC1270ANL, TC1271AL  
- 4.50V min./4.63V typ./4.75V max.).

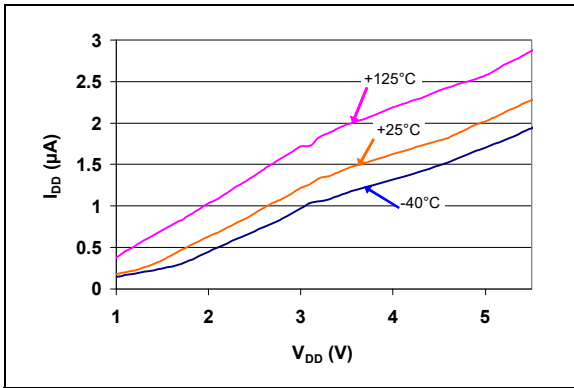

**FIGURE 2-8:**  $I_{DD}$  vs.  $V_{DD}$  (Reset Power-up Timer Inactive)  
(TC1270AT, TC1270ANT, TC1271AT  
- 3.00V min./3.08V typ./3.15V max.).

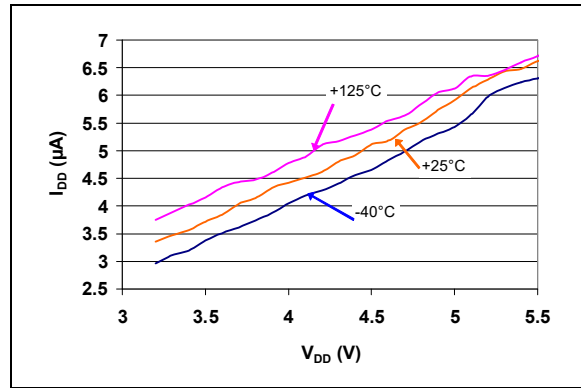

**FIGURE 2-11:**  $I_{DD}$  vs.  $V_{DD}$  (Reset Power-up Timer Active)  
(TC1270AT, TC1270ANT, TC1271AT  
- 3.00V min./3.08V typ./3.15V max.).

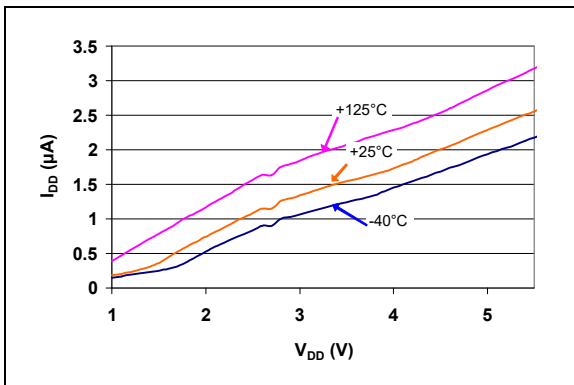

**FIGURE 2-9:**  $I_{DD}$  vs.  $V_{DD}$  (Reset Power-up Timer Inactive)  
(TC1270AR, TC1270ANR, TC1271AR  
- 2.55V min./2.63V typ./2.70V max.).

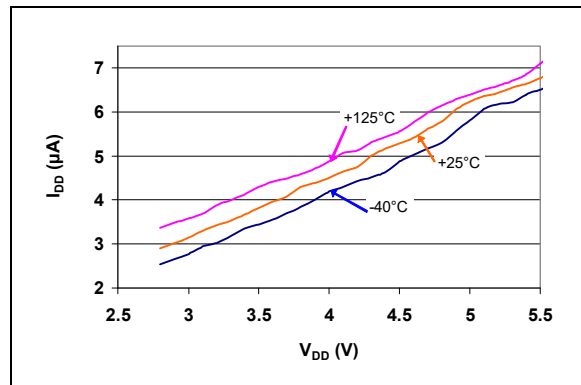

**FIGURE 2-12:**  $I_{DD}$  vs.  $V_{DD}$  (Reset Power-up Timer Active)  
(TC1270AR, TC1270ANR, TC1271AR  
- 2.55V min./2.63V typ./2.70V max.).

# TC1270A/70AN/71A

**Note:** Unless otherwise indicated, all limits are specified for  $V_{DD} = 1V$  to  $5.5V$ ,  $T_A = -40^{\circ}C$  to  $+125^{\circ}C$ .

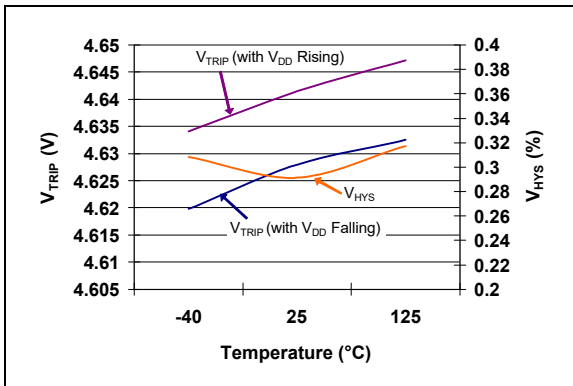

**FIGURE 2-13:**  $V_{TRIP}$  and  $V_{HYS}$  vs. Temperature  
(TC1270AL, TC1270ANL, TC1271AL - 4.50V min./4.63V typ./4.75V max.).

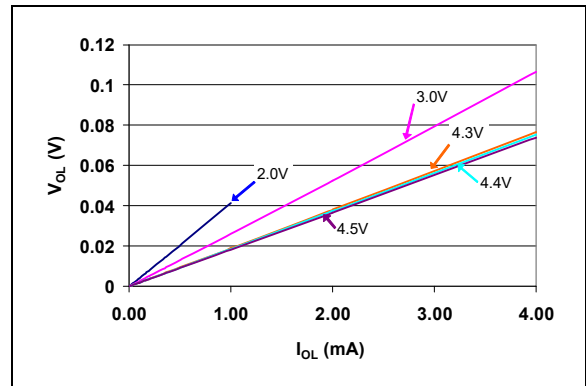

**FIGURE 2-16:**  $V_{OL}$  vs.  $I_{OL}$   
(TC1270AL, TC1270ANL, TC1271AL - 4.50V min./4.63V typ./4.75V max.).

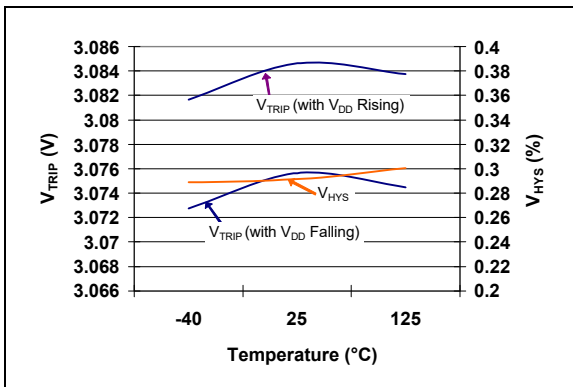

**FIGURE 2-14:**  $V_{TRIP}$  and  $V_{HYS}$  vs. Temperature  
(TC1270AT, TC1270ANT, TC1271AT - 3.00V min./3.08V typ./3.15V max.).

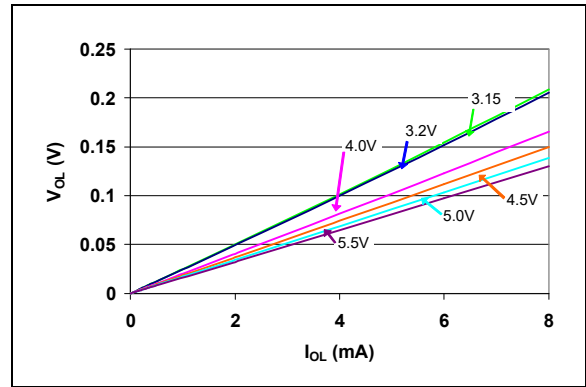

**FIGURE 2-17:**  $V_{OL}$  vs.  $I_{OL}$   
(TC1270AT, TC1270ANT, TC1271AT - 3.00V min./3.08V typ./3.15V max.).

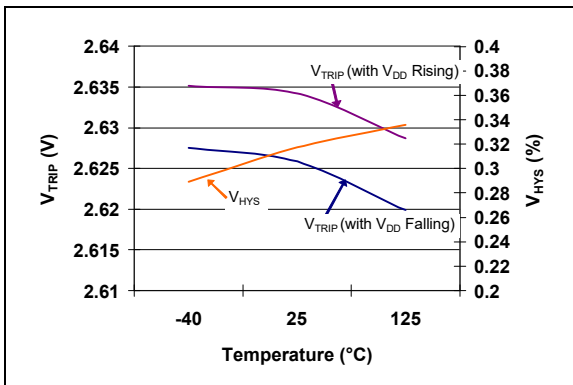

**FIGURE 2-15:**  $V_{TRIP}$  and  $V_{HYS}$  vs. Temperature  
(TC1270AR, TC1270ANR, TC1271AR - 2.55V min./2.63V typ./2.70V max.).

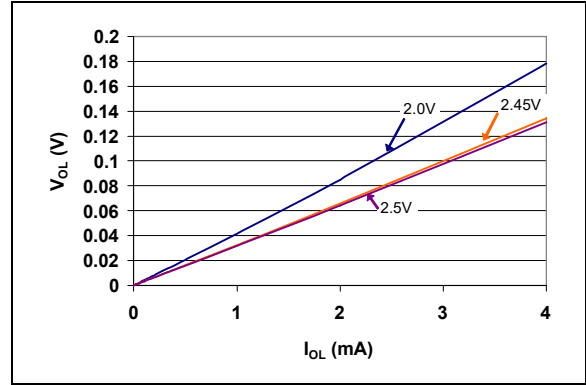

**FIGURE 2-18:**  $V_{OL}$  vs.  $I_{OL}$   
(TC1270AR, TC1270ANR, TC1271AR - 2.55V min./2.63V typ./2.70V max.).

# TC1270A/70AN/71A

**Note:** Unless otherwise indicated, all limits are specified for  $V_{DD} = 1V$  to  $5.5V$ ,  $T_A = -40^{\circ}C$  to  $+125^{\circ}C$ .

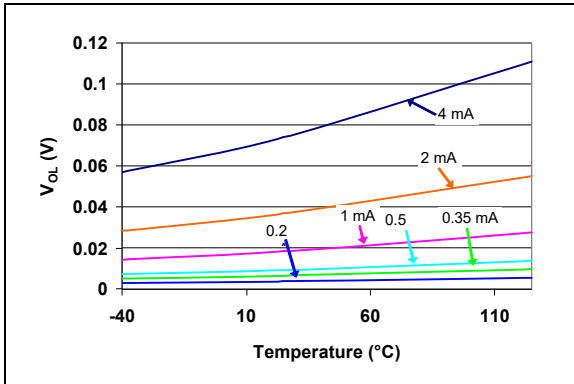

**FIGURE 2-19:**  $V_{OL}$  vs. Temperature  
(TC1270AL, TC1270ANL, TC1271AL  
- 4.50V min./4.63V typ./4.75V max.  
@  $V_{DD} = 4.5V$ ).

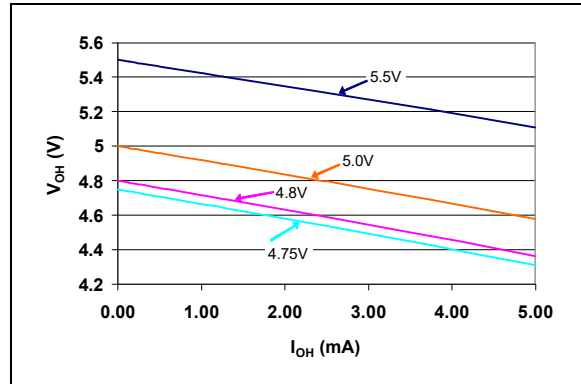

**FIGURE 2-22:**  $V_{OH}$  vs.  $I_{OH}$   
(TC1270AL, TC1270ANL, TC1271AL  
- 4.50V min./4.63V typ./4.75V max.  
@  $+25^{\circ}C$ ).

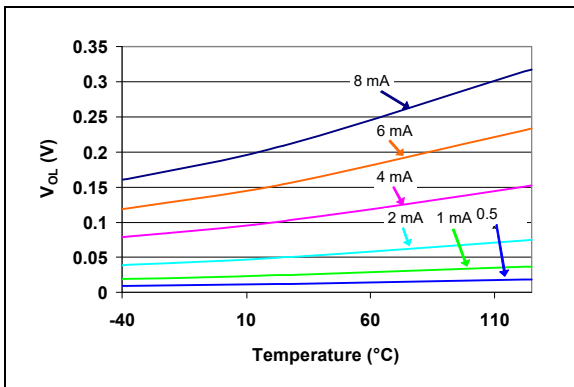

**FIGURE 2-20:**  $V_{OL}$  vs. Temperature  
(TC1270AT, TC1270ANT, TC1271AT  
- 3.00V min./3.08V typ./3.15V max.  
@  $V_{DD} = 2.7V$ ).

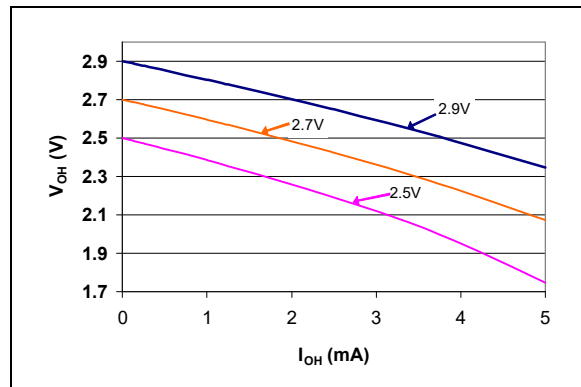

**FIGURE 2-23:**  $V_{OH}$  vs.  $I_{OH}$   
(TC1270AT, TC1270ANT, TC1271AT  
- 3.00V min./3.08V typ./3.15V max.  
@  $+25^{\circ}C$ ).

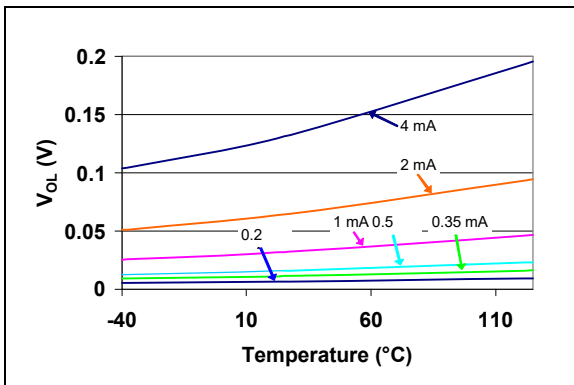

**FIGURE 2-21:**  $V_{OL}$  vs. Temperature  
(TC1270AR, TC1270ANR, TC1271AR  
- 2.55V min./2.63V typ./2.70V max.  
@  $V_{DD} = 1.8V$ ).

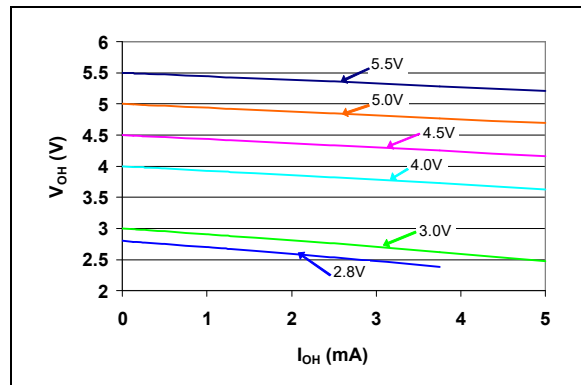

**FIGURE 2-24:**  $V_{OH}$  vs.  $I_{OH}$   
(TC1270AR, TC1270ANR, TC1271AR  
- 2.55V min./2.63V typ./2.70V max.  
@  $+25^{\circ}C$ ).

# TC1270A/70AN/71A

**Note:** Unless otherwise indicated, all limits are specified for  $V_{DD} = 1V$  to  $5.5V$ ,  $T_A = -40^{\circ}C$  to  $+125^{\circ}C$ .

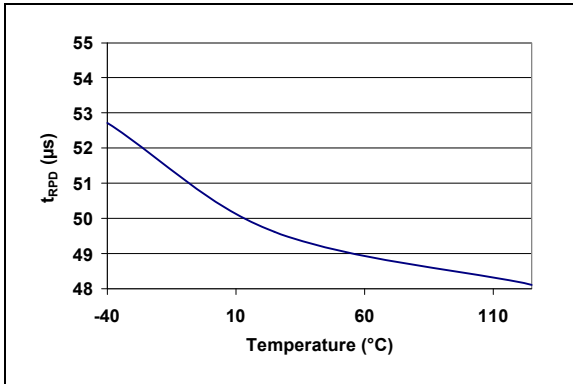

**FIGURE 2-25:**  $V_{DD}$  Falling to Reset Propagation Delay ( $t_{RPD}$ ) vs. Temperature (TC1270AL, TC1270ANL, TC1271AL - 4.50V min./4.63V typ./4.75V max.).

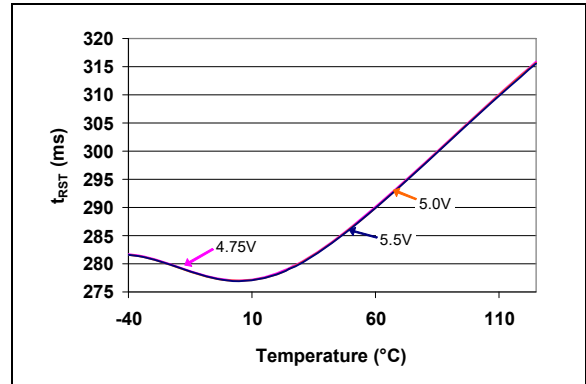

**FIGURE 2-28:** Reset Time-Out Period ( $t_{RST}$ ) vs. Temperature (TC1270AL, TC1270ANL, TC1271AL - 4.50V min./4.63V typ./4.75V max.).

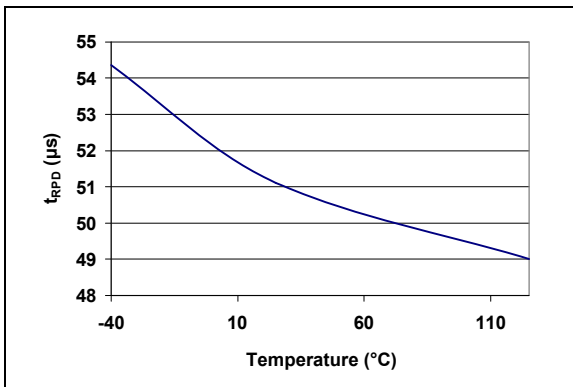

**FIGURE 2-26:**  $V_{DD}$  Falling to Reset Propagation Delay ( $t_{RPD}$ ) vs. Temperature (TC1270AT, TC1270ANT, TC1271AT - 3.00V min./3.08V typ./3.15V max.).

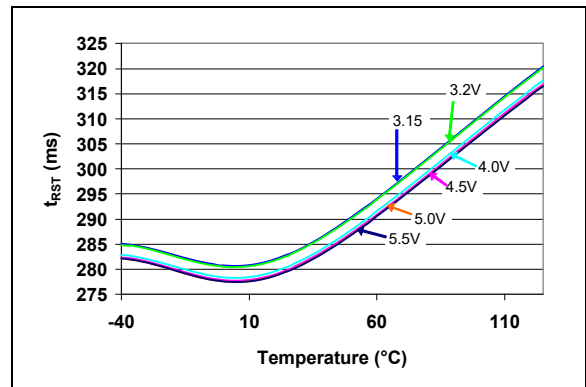

**FIGURE 2-29:** Reset Time-Out Period ( $t_{RST}$ ) vs. Temperature (TC1270AT, TC1270ANT, TC1271AT - 3.00V min./3.08V typ./3.15V max.).

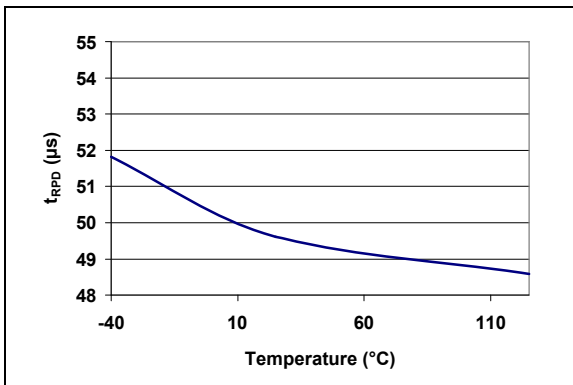

**FIGURE 2-27:**  $V_{DD}$  Falling to Reset Propagation Delay ( $t_{RPD}$ ) vs. Temperature (TC1270AR, TC1270ANR, TC1271AR - 2.55V min./2.63V typ./2.70V max.).

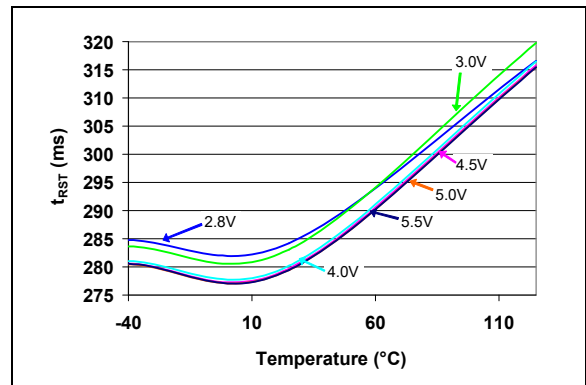
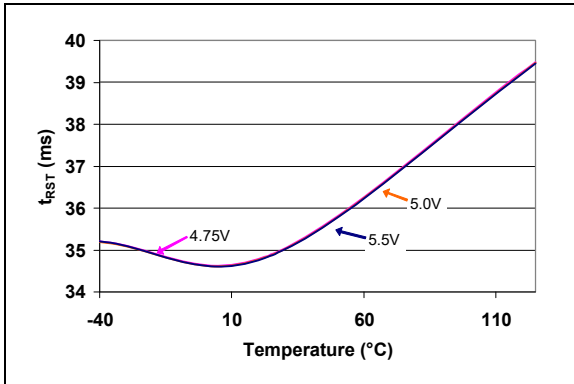

**FIGURE 2-30:** Reset Time-Out Period ( $t_{RST}$ ) vs. Temperature (TC1270AR, TC1270ANR, TC1271AR - 2.55V min./2.63V typ./2.70V max.).



# TC1270A/70AN/71A

**Note:** Unless otherwise indicated, all limits are specified for  $V_{DD} = 1V$  to  $5.5V$ ,  $T_A = -40^{\circ}C$  to  $+125^{\circ}C$ .



**FIGURE 2-31:** Reset Time-Out Period ( $t_{RST}$ ) (C time out option) vs. Temperature (TC1270AL, TC1270ANL, TC1271AL - 4.50V min./4.63V typ./4.75V max.).

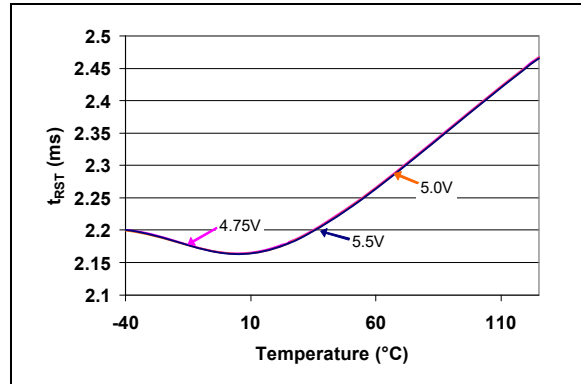

**FIGURE 2-34:** Reset Time-Out Period ( $t_{RST}$ ) (B time out option) vs. Temperature (TC1270AL, TC1270ANL, TC1271AL - 4.50V min./4.63V typ./4.75V max.).

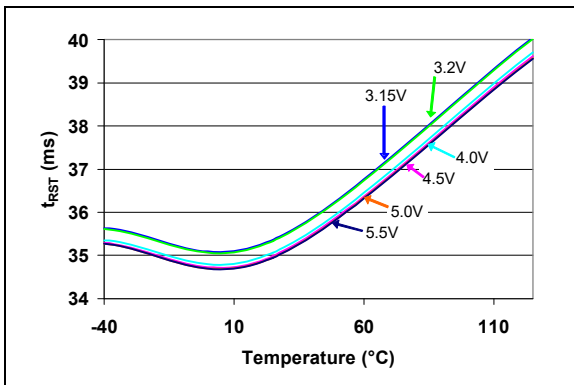

**FIGURE 2-32:** Reset Time-Out Period ( $t_{RST}$ ) (C time out option) vs. Temperature (TC1270AT, TC1270ANT, TC1271AT - 3.00V min./3.08V typ./3.15V max.).

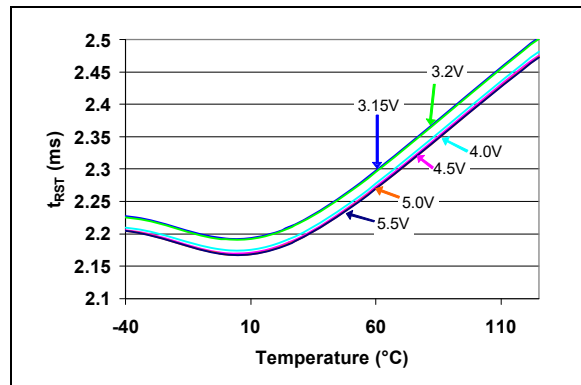

**FIGURE 2-35:** Reset Time-Out Period ( $t_{RST}$ ) (B time out option) vs. Temperature (TC1270AT, TC1270ANT, TC1271AT - 3.00V min./3.08V typ./3.15V max.).

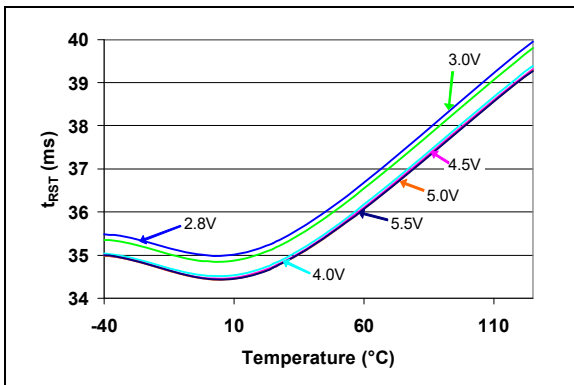

**FIGURE 2-33:** Reset Time-Out Period ( $t_{RST}$ ) (C time out option) vs. Temperature (TC1270AR, TC1270ANR, TC1271AR - 2.55V min./2.63V typ./2.70V max.).

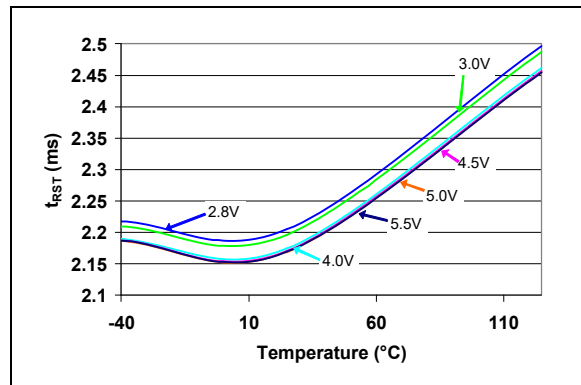

**FIGURE 2-36:** Reset Time-Out Period ( $t_{RST}$ ) (B time out option) vs. Temperature (TC1270AR, TC1270ANR, TC1271AR - 2.55V min./2.63V typ./2.70V max.).

# TC1270A/70AN/71A

**Note:** Unless otherwise indicated, all limits are specified for  $V_{DD} = 1V$  to  $5.5V$ ,  $T_A = -40^{\circ}C$  to  $+125^{\circ}C$ .

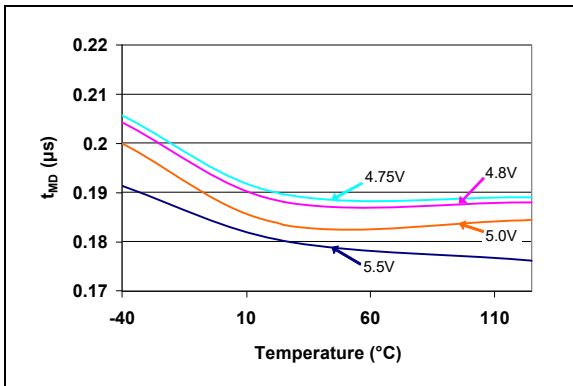

**FIGURE 2-37:**  $\overline{MR}$  Low to Reset Propagation Delay ( $t_{MD}$ ) vs. Temperature (TC1270AL, TC1270ANL, TC1271AL - 4.50V min./4.63V typ./4.75V max.).

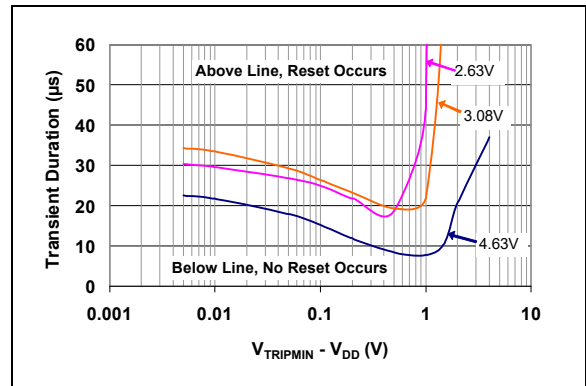

**FIGURE 2-40:**  $V_{DD}$  Transient Duration vs. Reset Threshold Overdrive ( $V_{TRIP}$  (minimum) -  $V_{DD}$ ).

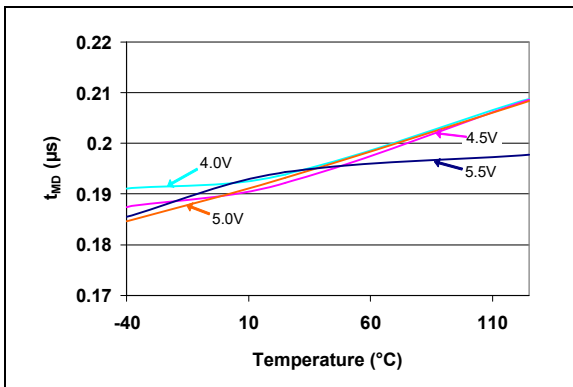

**FIGURE 2-38:**  $\overline{MR}$  Low to Reset Propagation Delay ( $t_{MD}$ ) vs. Temperature (TC1270AT, TC1270ANT, TC1271AT - 3.00V min./3.08V typ./3.15V max.).

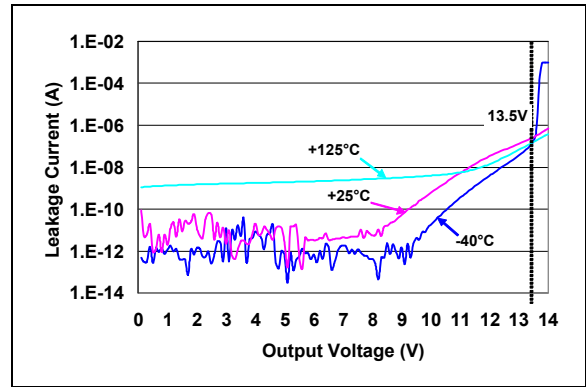

**FIGURE 2-41:** Open-Drain Leakage Current vs. Voltage Applied to  $\overline{RST}$  Pin (TC1270AR, TC1270ANR, TC1271AR - 2.55V minimum).

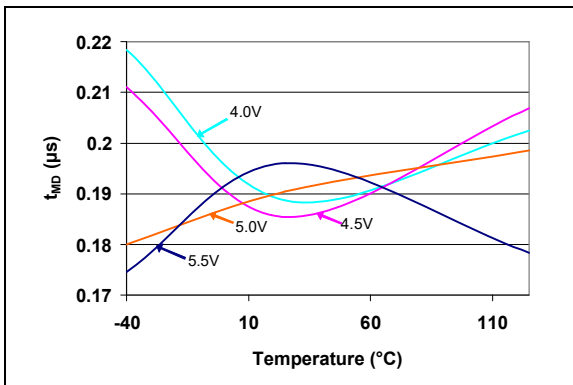

**FIGURE 2-39:**  $\overline{MR}$  Low to Reset Propagation Delay ( $t_{MD}$ ) vs. Temperature (TC1270AR, TC1270ANR, TC1271AR - 2.55V min./2.63V typ./2.70V max.).

# TC1270A/70AN/71A

## 3.0 PIN DESCRIPTIONS

Descriptions of the pins are listed in [Table 3-1](#).

**TABLE 3-1: PINOUT DESCRIPTION**

Pin Number						Sym.	Pin		Standard Function
TC1270A (Push-Pull, active-low)		TC1270AN (Open-Drain, active-low)		TC1271A (Push-Pull, active-high)			Type	Buffer / Driver	
SOT-23-5	SOT-143-4	SOT-23-5	SOT-143-4	SOT-23-5	SOT-143-4				
5	1	5	1	5	1	$V_{SS}$	—	Power	Ground
4	2	—	—	—	—	$\overline{RST}$	O	Push-Pull	Reset output (Push-Pull), active-low $H = V_{DD} > V_{TRIP}$ , Reset pin is inactive (after Reset Delay Timer completes) $L = V_{DD} < V_{TRIP}$ , Reset pin is active  Goes active (Low) if one of these conditions occurs: 1. If $V_{DD}$ falls below the selected Reset voltage threshold. 2. If the $\overline{MR}$ pin is forced low. 3. During power-up.
—	—	4	2	—	—	$\overline{RST}$	O	Open-Drain	Reset output (Open-Drain), active-low $Float = V_{DD} > V_{TRIP}$ , Reset pin is inactive (after Reset Delay Timer completes) $L = V_{DD} < V_{TRIP}$ , Reset pin is active  Goes active (Low) if one of these conditions occurs: 1. If $V_{DD}$ falls below the selected Reset voltage threshold. 2. If the $\overline{MR}$ pin is forced low. 3. During power-up.
—	—	—	—	4	2	RST	O	Push-Pull	Reset output (Push-Pull), active-high $H = V_{DD} < V_{TRIP}$ , Reset pin is active $L = V_{DD} > V_{TRIP}$ , Reset pin is inactive (after Reset Delay Timer completes)  Goes active (High) if one of these conditions occurs: 1. If $V_{DD}$ falls below the selected Reset voltage threshold. 2. If the $\overline{MR}$ pin is forced low. 3. During power-up.

**Note 1:** The  $\overline{MR}$  pin has an internal weak pull-up (18.5 k $\Omega$  typical).

**TABLE 3-1: PINOUT DESCRIPTION (CONTINUED)**

Pin Number						Sym.	Pin		Standard Function
TC1270A (Push-Pull, active-low)		TC1270AN (Open-Drain, active-low)		TC1271A (Push-Pull, active-high)			Type	Buffer / Driver	
SOT-23-5	SOT-143-4	SOT-23-5	SOT-143-4	SOT-23-5	SOT-143-4				
3	3	3	3	3	3	$\overline{\text{MR}}$	I	ST <sup>(1)</sup>	Manual Reset Input Pin This input allows a push button switch to be directly connected to a TC1270A/70AN/71A device's $\overline{\text{MR}}$ pin, which can be used to force a system Reset. The input filter ignores noise pulses that occur on the $\overline{\text{MR}}$ pin. H = Switch is open (internal pull-up resistor pulls signal high). State of the RST/ $\overline{\text{RST}}$ pin is determined by other system conditions. L = Switch is depressed (shorted to ground). This forces the RST/ $\overline{\text{RST}}$ pin Active.
2	4	2	4	2	4	$V_{\text{DD}}$	—	Power	Supply Voltage
1	—	1	—	1	—	NC	—	—	No Connection

**Note 1:** The  $\overline{\text{MR}}$  pin has an internal weak pull-up (18.5 k $\Omega$  typical).

### 3.1 Ground Terminal ( $V_{\text{SS}}$ )

$V_{\text{SS}}$  provides the negative reference for the analog input voltage. Typically, the circuit ground is used.

### 3.2 Supply Voltage ( $V_{\text{DD}}$ )

$V_{\text{DD}}$  can be used for power supply monitoring or a voltage level that requires monitoring.

### 3.3 Reset Output (RST and $\overline{\text{RST}}$ )

There are three types of Reset output pins. These are:

1. Push-Pull active-low Reset
2. Push-Pull active-high Reset
3. Open-Drain active-low Reset, external pull-up resistor required.

#### 3.3.1 ACTIVE-LOW ( $\overline{\text{RST}}$ ) – PUSH-PULL

The  $\overline{\text{RST}}$  push-pull output remains low while  $V_{\text{DD}}$  is below the Reset voltage threshold ( $V_{\text{TRIP}}$ ). The time that the  $\overline{\text{RST}}$  pin is held low after the device voltage ( $V_{\text{DD}}$ ) returns to a high level ( $> V_{\text{TRIP}}$ ) is typically 280 ms. After the Reset Delay Timer expires, the  $\overline{\text{RST}}$  pin will be driven to the high state.

#### 3.3.2 ACTIVE-HIGH (RST) – PUSH-PULL

The RST push-pull output remains high while  $V_{\text{DD}}$  is below the Reset voltage threshold ( $V_{\text{TRIP}}$ ). The time that the RST pin is held high after the device voltage ( $V_{\text{DD}}$ ) returns to a high level ( $> V_{\text{TRIP}}$ ) is typically 280 ms. After the Reset Delay Timer expires, the RST pin will be driven to the low state.

#### 3.3.3 ACTIVE-LOW ( $\overline{\text{RST}}$ ) – OPEN-DRAIN

The  $\overline{\text{RST}}$  open-drain output remains low while  $V_{\text{DD}}$  is below the Reset voltage threshold ( $V_{\text{TRIP}}$ ). The time that the  $\overline{\text{RST}}$  pin is held low after the device voltage ( $V_{\text{DD}}$ ) returns to a high level ( $> V_{\text{TRIP}}$ ) depends on the Reset time-out selected. After the Reset Delay Timer expires, the  $\overline{\text{RST}}$  pin will float.

### 3.4 Manual Reset Input ( $\overline{\text{MR}}$ )

The Manual Reset ( $\overline{\text{MR}}$ ) input pin allows a push button switch to easily be connected to the system. When the push button is depressed, it forces a system Reset. This pin has circuitry that filters noise that may be present on the  $\overline{\text{MR}}$  signal.

The  $\overline{\text{MR}}$  pin is active-low and has an internal pull-up resistor.

# TC1270A/70AN/71A

## 4.0 DEVICE OPERATION

### 4.1 General Description

For many of today's microcontroller applications, care must be taken to prevent low-power conditions that can cause many different system problems. The most common causes are brown-out conditions, where the system supply drops below the operating level momentarily. The second most common cause is when a slowly decaying power supply causes the microcontroller to begin executing instructions without sufficient voltage to sustain volatile memory (RAM), thus producing indeterminate results.

The TC127XA family (TC1270A, TC1270AN and TC1271A) are cost-effective voltage supervisor devices designed to keep a microcontroller in Reset until the system voltage has reached and stabilized at the proper level for reliable system operation. These devices also operate as protection from brown-out conditions when the system supply voltage drops below a safe operating level.

A Manual Reset input ( $\overline{\text{MR}}$  pin) is provided. This allows a push button switch to be directly connected to the TC127XA device, and is suitable for use as a push button Reset. This allows the system to easily be reset from the external control of the push button switch. No external components are required.

The Reset pin (RST or  $\overline{\text{RST}}$ ) will be forced active, if any of the following occur:

- During device power-up
- $V_{\text{DD}}$  goes below the device threshold voltage
- The Manual Reset input ( $\overline{\text{MR}}$ ) goes low

Figure 4-1 shows a high level block diagram of the devices. The device can be described with three functional blocks. These are:

- Voltage detect circuit
- Manual Reset with glitch filter circuit
- Reset generator circuit

The Reset generator circuit controls the Reset delay time of the Reset output signal.

There are three Reset Delay Timer options. Depending on the option, the Reset signal ( $\overline{\text{RST}}$ /RST pin) will be held active for a minimum of 1.09 ms, 17.5 ms, or 140 ms.

The TC1271A has an active-high RST output while the TC1270A and TC1270AN have an active-low  $\overline{\text{RST}}$  output.

The TC1270A and TC1271A have a push-pull output driver, while the TC1270AN has an open-drain output.

Figure 4-2 shows a typical circuit for a push-pull device and Figure 4-3 shows a typical circuit for an open-drain device.

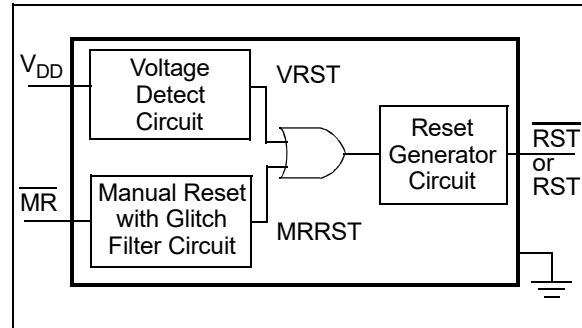

FIGURE 4-1: TC127XA High Level Block Diagram.

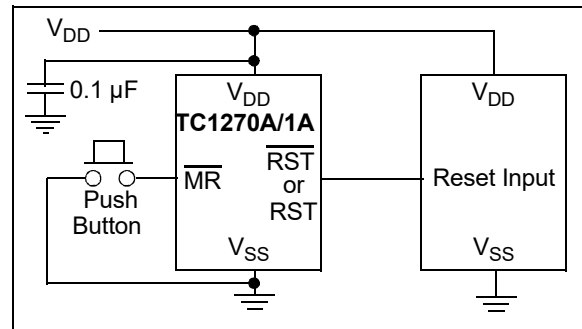

FIGURE 4-2: Typical Push-Pull Application Circuit.

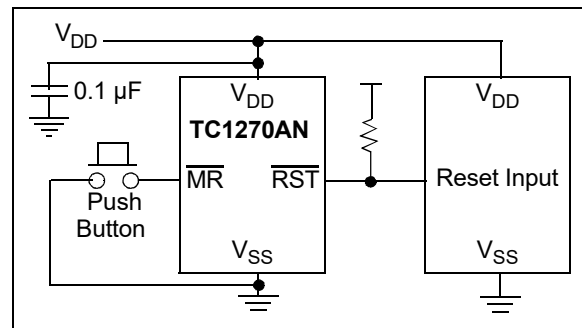

FIGURE 4-3: Typical Open-Drive Application Circuit.

The TC1270A and TC1271A devices are available in a 4-Pin SOT-143 package (to maintain footprint compatibility with the TC1270, TC1271, TCM811 and TCM812 devices) and a SOT-23-5 package. The TC1270AN is only available in the SOT-23-5 package.

Low supply current makes these devices suitable for battery-powered applications.

Device specific block diagrams are presented in Figure 4-4 through Figure 4-6.

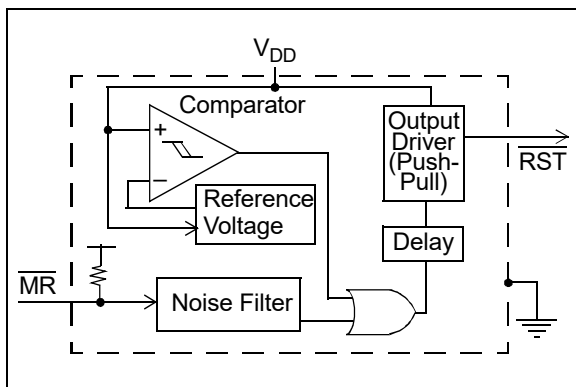

FIGURE 4-4: TC1270A Block Diagram.

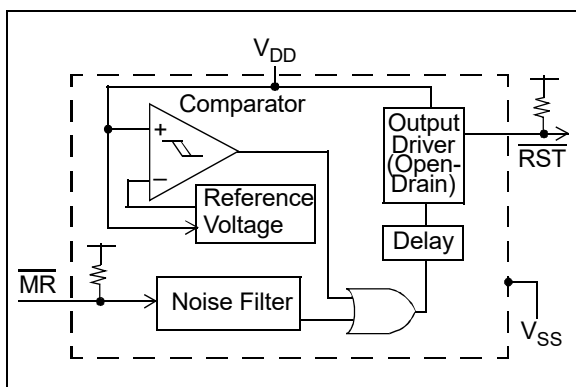

FIGURE 4-5: TC1270AN Block Diagram.

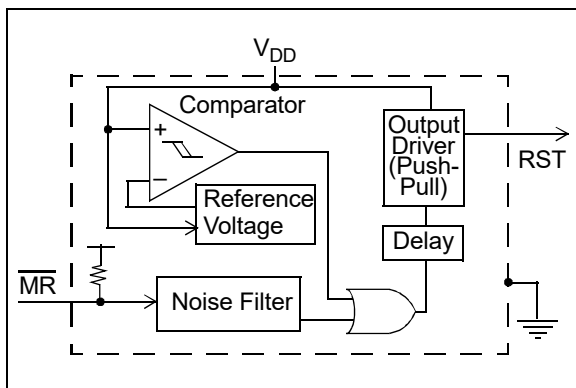

FIGURE 4-6: TC1271A Block Diagram.

## 4.2 Voltage Detect Circuit

The voltage detect circuit monitors  $V_{DD}$ . The device's Reset voltage trip point ( $V_{TRIP}$ ) is selected when the device is ordered. The voltage on the device's  $V_{DD}$  pin determines the output state of the  $\overline{RST}/RST$  pin.

$V_{DD}$  voltages above the  $V_{TRIP(MAX)}$  force the  $\overline{RST}/RST$  pin inactive.  $V_{DD}$  voltages below the  $V_{TRIP(MIN)}$  force the  $\overline{RST}/RST$  pin active. The state of the  $\overline{RST}/RST$  pin is unknown for  $V_{DD}$  voltages between  $V_{TRIP(MAX)}$  and  $V_{TRIP(MIN)}$ . This is shown in Table 4-1

TABLE 4-1:  $V_{DD}$  LEVELS TO  $\overline{RST}/RST$  OUTPUT STATES

$V_{DD}$ Voltage Level	Output State	
	$\overline{RST}$	RST
$V_{DD} \geq V_{TRIP(MAX)}$	H <sup>(1, 2)</sup>	L <sup>(1)</sup>
$V_{TRIP(MIN)} < V_{DD} < V_{TRIP(MAX)}$	U	U
$V_{DD} \leq V_{TRIP(MIN)}$	L	H

**Legend:** H = Driven High L = Driven Low  
U = Unknown, driven either High or Low

**Note 1:** The  $\overline{RST}/RST$  pin will be driven inactive after the Reset Delay Timer ( $t_{RST}$ ) times out.

**2:** The TC1270AN  $\overline{RST}$  pin will be floated after the Reset Delay Timer ( $t_{RST}$ ) times out.

The term  $V_{TRIP}$  will be used as the general term for the trip point voltage where the device actually trips.

In the case where  $V_{DD}$  is falling (for voltages starting above  $V_{TRIP(MAX)}$ ):

- Voltages above  $V_{TRIP(MAX)}$  will never cause the  $\overline{RST}/RST$  output pin to be driven active.
- Voltages below  $V_{TRIP(MIN)}$  will always cause the  $\overline{RST}/RST$  output pin to be driven active.

In the case where  $V_{DD}$  is rising (for voltages starting below  $V_{TRIP(MIN)}$ ):

- Voltages above  $V_{TRIP(MAX)}$  will always cause the  $\overline{RST}/RST$  output pin to be driven inactive, (or floated, in the TC1270AN) after the Reset Delay Timer ( $t_{RST}$ ), times out.

Table 4-2 shows the various device trip point options and their  $V_{TRIP(MAX)}$  and  $V_{TRIP(MIN)}$  voltages. The negative percentage change from common regulated voltages is also shown.

If the  $V_{DD}$  is falling from the regulated voltage as it crosses the  $V_{TRIP}$  voltage, the  $\overline{RST}/RST$  pin is driven active. Then, the desired circuitry is forced into Reset, or the circuitry has the indication that the  $V_{DD}$  is below the selected  $V_{TRIP}$ .

# TC1270A/70AN/71A

If the  $V_{DD}$  is rising as it crosses the  $V_{TRIP}$  voltage, the  $\overline{RST}/RST$  pin is driven inactive after the Reset Delay Timer elapses. Then, the desired circuitry is released from Reset and will start to operate in its Normal mode, or the circuitry has the indication that the  $V_{DD}$  is above the selected  $V_{TRIP}$ .

**TABLE 4-2: SELECTING THE TRIP POINT**

Trip Voltage Selection	$V_{TRIP(MAX)}^{(1)}$ / $V_{TRIP(MIN)}^{(2)}$	- % From Regulated Voltage		
		5.0V	3.3V	3.0V
L	4.75V	5.0%	—	—
	4.50V	10.0%	—	—
M	4.50V	10.0%	—	—
	4.25V	15.0%	—	—
T	3.15V	—	4.5%	—
	3.00V	—	9.2%	—
S	3.00V	—	9.2%	—
	2.85V	—	13.7%	—
R	2.70V	—	—	10.0%
	2.55V	—	—	15.0%

- Note 1:** Voltage regulator circuit must have tighter tolerance (%) than  $V_{TRIP(MAX)}$ % from regulated voltage.
- 2:** Circuitry being reset must have a wider tolerance (%) than  $V_{TRIP(MIN)}$ % from regulated voltage.

The TC1270A/TC1270AN/TC1271A devices are optimized to reject fast transient glitches on the  $V_{DD}$  line. If the low input signal (which is below  $V_{TRIP}$ ) is not rejected, the Reset output is driven active within 50  $\mu$ s of  $V_{DD}$  falling through the Reset voltage threshold.

After the device exits the Reset condition, the delay circuitry will hold the  $\overline{RST}/RST$  pin active until the appropriate Reset delay time ( $t_{RST}$ ) has elapsed.

During device power-up, the input voltage is below the trip point voltage. The device must enter the valid operating range for the device to start operation.

## 4.2.1 HYSTERESIS

There is also a minimal hysteresis ( $V_{HYS}$ ) on the trip point. This is so that small noise signals on the device voltage ( $V_{DD}$ ) do not cause the Reset pin ( $\overline{RST}/RST$ ) to “jitter” (oscillate between active and inactive levels).

The characterization graphs shown in Figures 2-13 through 2-15 show the device hysteresis as a percentage of the voltage trip point ( $V_{TRIP}$ ).

The Reset Delay Timer ( $t_{RST}$ ) gives a time-based hysteresis for the system.

## 4.2.2 POWER-UP/RISING $V_{DD}$

As the device  $V_{DD}$  rises, the device’s Reset circuit will remain active until the voltage rises above the “actual” trip point ( $V_{TRIP}$ ).

Figure 4-7 shows a power-up sequence and the waveform of the  $\overline{RST}$  and RST pins. As the device powers up, the voltage will start below the valid operating voltage of the device. At this voltage, the  $\overline{RST}/RST$  output is not valid. Once the voltage is above the minimum operating voltage (1V) and below the selected  $V_{TRIP}$ , the Reset output will be active.

Once the device voltage rises above the  $V_{TRIP}$  voltage, the Reset Delay Timer ( $t_{RST}$ ) starts. When the Reset Delay Timer times out, the Reset output ( $\overline{RST}/RST$ ) is driven inactive.

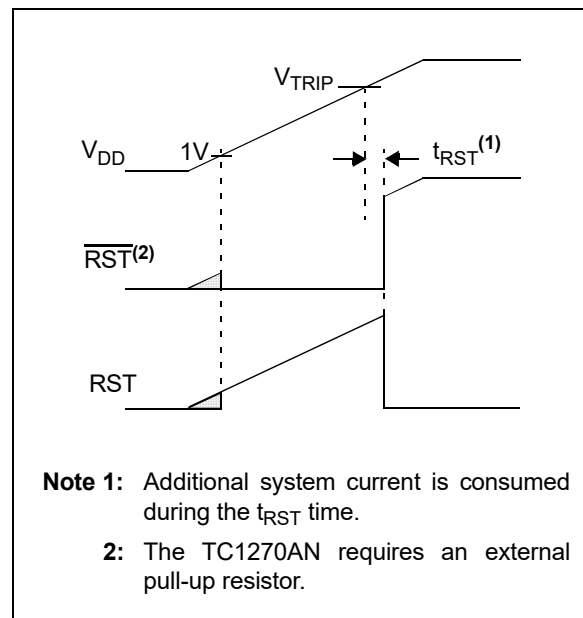

**FIGURE 4-7:**  $\overline{RST}/RST$  Pin Operation Power-up.

## 4.2.3 POWER-DOWN/BROWN-OUT

As the device powers-down/browns-out, the  $V_{DD}$  falls from a voltage above the devices trip point ( $V_{TRIP}$ ). The device will trip at a voltage between the maximum trip point ( $V_{TRIP(MAX)}$ ) and the minimum trip point ( $V_{TRIP(MIN)}$ ). Once the device voltage ( $V_{DD}$ ) goes below this voltage, the  $\overline{RST}/RST$  pin will be forced to the active state. Table 4-3 shows the state of the  $\overline{RST}$  or RST pins.

Figure 4-8 shows the waveform of the  $\overline{RST}$  pin as determined by the  $V_{DD}$  voltage. As the  $V_{DD}$  voltage falls from the normal operating point, the device “enters” Reset by crossing the  $V_{TRIP}$  voltage (between  $V_{TRIP(MAX)}$  and  $V_{TRIP(MIN)}$ ). Then, when  $V_{DD}$  voltage rises, the device “exits” Reset by crossing the  $V_{TRIP}$  voltage (below, or at,  $V_{TRIP(MAX)}$ ). After the “exit” state

has been detected, the Reset Delay Timer ( $t_{RST}$ ) starts. When the  $t_{RST}$  time completes, the Reset pin is driven inactive.

**TABLE 4-3: RESET PIN STATES**

Device	State of $\overline{RST}$ Pin when:		State of RST Pin when:		Output Driver
	$V_{DD} < V_{TRIP}$	$V_{DD} > V_{TRIP}^{(1)}$	$V_{DD} < V_{TRIP}$	$V_{DD} > V_{TRIP}^{(1)}$	
TC1270A	L	H	—	—	Push-Pull
TC1271A	—	—	H	L	Push-Pull

**Note 1:** The  $\overline{RST}/RST$  pin will be driven inactive after the Reset Delay Timer ( $t_{RST}$ ) times out.

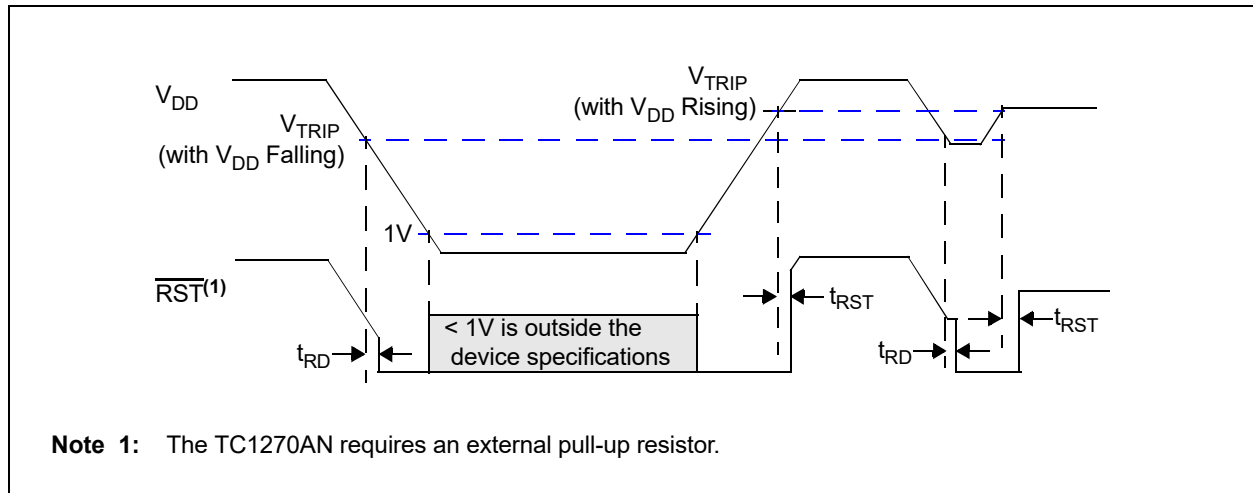

**FIGURE 4-8:**  $\overline{RST}$  Operation as Determined by the  $V_{TRIP}$ .



# TC1270A/70AN/71A

## 4.3 Negative-Going $V_{DD}$ Transients

The minimum pulse width (time) required to cause a Reset may be an important criteria in the implementation of a Power-on Reset (POR) circuit. This time is referred to as transient duration. The TC127XA devices are designed to reject a level of negative-going transients (glitches) on the power supply line.

Transient duration is the amount of time needed for these supervisory devices to respond to a drop in  $V_{DD}$ . The transient duration time ( $t_{TRAN}$ ) is dependent on the magnitude of  $V_{TRIP} - V_{DD}$  (overdrive). Any combination of duration and overdrive that lies under the duration/overdrive curve will not generate a Reset signal. Generally speaking, the transient duration time decreases with an increase in the  $V_{TRIP} - V_{DD}$  voltage.

Figure 4-9 shows an example transient duration vs. Reset comparator overdrive. It shows that the farther below the trip point the transient pulse goes, the shorter the duration of the pulse required to cause a Reset gets. So, any combination of duration and overdrive that lays **under** the curve will **not** generate a Reset signal. Combinations **above** the curve are detected as a brown-out or power-down.

Transient immunity can be improved by adding a bypass capacitor (typically 0.1  $\mu\text{F}$ ) as close as possible to the  $V_{DD}$  pin of the TC127XA device.

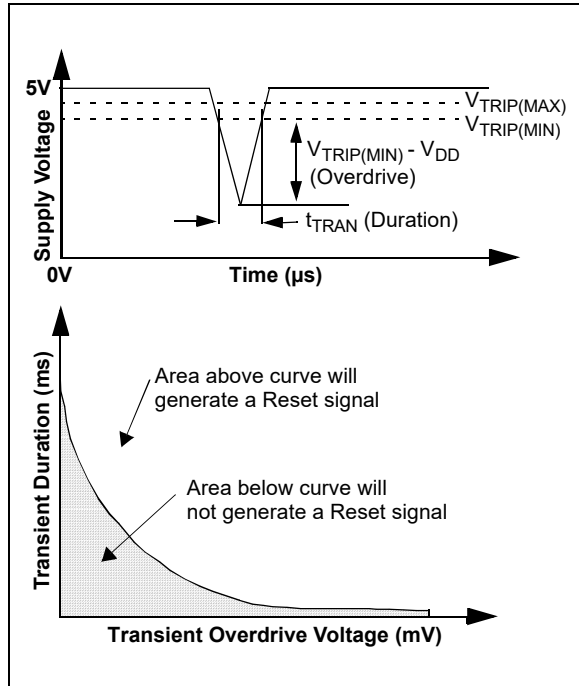

FIGURE 4-9: Example of Typical Transient Duration Waveform.

## 4.4 Manual Reset with Glitch Filter Circuit

The Manual Reset input pin ( $\overline{\text{MR}}$ ) allows the Reset pins ( $\text{RST}/\overline{\text{RST}}$ ) to be manually forced to their active states. The  $\overline{\text{MR}}$  pin has circuitry to filter noise pulses that may be present on the pin. Figure 4-10 shows a block diagram for using the TC127XA with a push button switch. To minimize the required external components, the  $\overline{\text{MR}}$  input has an internal pull-up resistor.

A mechanical push button or active logic signal can drive the  $\overline{\text{MR}}$  input.

Once  $\overline{\text{MR}}$  has been low for a time,  $t_{MD}$  (the manual Reset delay time), the Reset output pins are forced active. The Reset output pins will remain in their active states for the Reset Delay Timer time-out period ( $t_{RST}$ ).

Figure 4-11 shows a waveform for the manual Reset switch input and the Reset pins output.

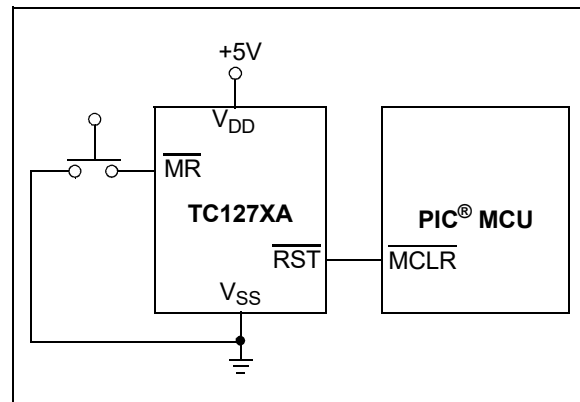

FIGURE 4-10: Push Button Reset.

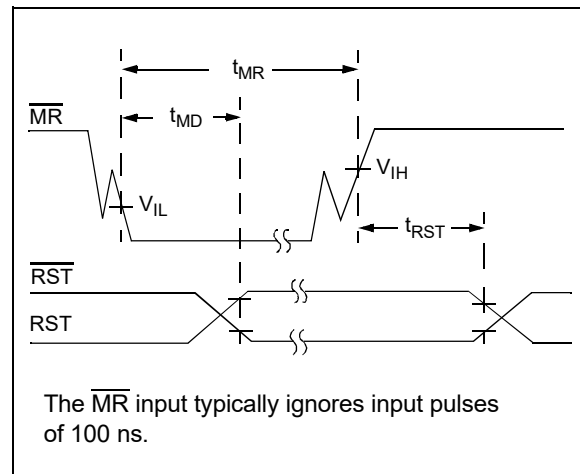

FIGURE 4-11:  $\overline{\text{MR}}$  Input – Push Button.

### 4.4.1 NOISE FILTER

The noise filter filters out noise spikes (glitches) on the Manual Reset pin ( $\overline{\text{MR}}$ ). Noise spikes less than 100 ns (typical) are filtered.

## 4.5 Reset Generator Circuit

The output signals from the voltage detect circuit and the manual Reset with glitch filter circuit are OR'd together and used to activate the Reset generator module.

After the Reset conditions have been removed (the  $\overline{MR}$  pin is no longer forced low and the input voltage is greater than the trip point voltage), the Reset generator circuit determines the Reset delay time-out required.

There are three options for the delay circuit. These are:

- 2.19 ms (typical) delay
- 35 ms (typical) delay
- 280 ms (typical) delay

### 4.5.1 RESET DELAY TIMER

The Reset Delay Timer ensures that the TC127XA device will “hold” the embedded system in Reset until the system voltage has stabilized. The Reset Delay Timer time-out is shown in [Table 4-4](#).

The Reset Delay Timer starts when the voltage detect circuit output AND the manual Reset with glitch filter circuit output become inactive. While the Reset Delay Timer is active, the  $\overline{RST}$  or RST pin is driven to the active state. When the Reset Delay Timer times out, the  $\overline{RST}$  or RST pin is driven inactive.

The Reset Delay Timer ( $t_{RST}$ ) starts after the device voltage rises above the “actual” trip point ( $V_{TRIP}$ ). When the Reset Delay Timer times out, the Reset output pin ( $\overline{RST}/RST$ ) is driven inactive.

The Reset Delay Timer is cleared if either, or both, the voltage detector circuit output and the manual Reset with glitch filter circuit output become active. The  $\overline{RST}$  or RST pin continues to be driven to the active state.

[Figure 4-12](#) illustrates when the Reset Delay Timer ( $t_{RST}$ ) is active or inactive.

### 4.5.2 EFFECT OF TEMPERATURE ON RESET POWER-UP TIMER ( $t_{RPU}$ )

The Reset Delay Timer time-out period ( $t_{RST}$ ) determines how long the device remains in the Reset condition. This time out is affected by the device  $V_{DD}$  and the temperature. Typical responses for varying  $V_{DD}$  values and temperatures are presented in [Figures 2-28](#), [2-29](#) and [2-30](#).

**TABLE 4-4: RESET DELAY TIMER TIME OUTS**

$t_{RST}$			Units
Min.	Typ.	Max.	
1.09	2.19	4.38	ms
17.5	35	70	ms
140	280	560	ms

↑

This is the minimum time that the Reset Delay Timer will “hold” the Reset pin active after  $V_{DD}$  rises above  $V_{TRIP}$

↑

This is the maximum time that the Reset Delay Timer will “hold” the Reset pin active after  $V_{DD}$  rises above  $V_{TRIP}$

**Note 1:** Shaded rows are custom-ordered time outs.

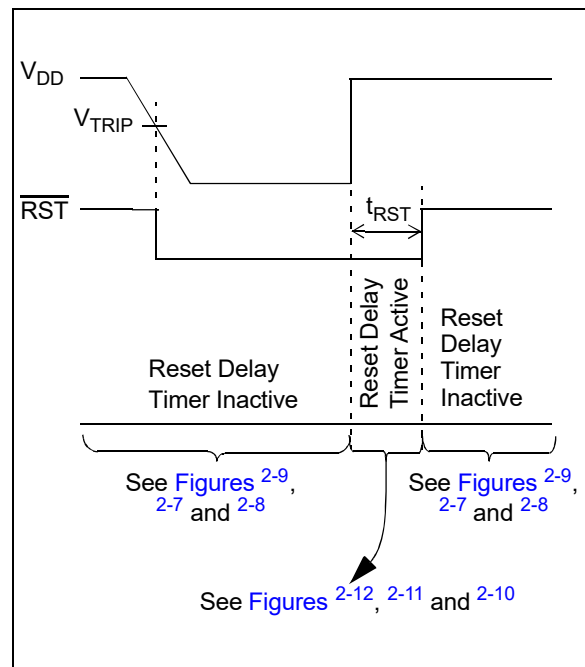

**FIGURE 4-12: Reset Power-Up Timer Waveform.**

# TC1270A/70AN/71A

## 5.0 APPLICATION INFORMATION

This section presents application-related information that may be useful for your particular design requirements.

### 5.1 Supply Monitor Noise Sensitivity

The TC127XA devices are optimized for fast responses to negative-going changes in  $V_{DD}$ . A system with an inordinate amount of electrical noise on  $V_{DD}$  (such as a system using relays) may require a 0.01  $\mu\text{F}$  or 0.1  $\mu\text{F}$  bypass capacitor to reduce detection sensitivity. This capacitor should be installed as close to the TC127XA as possible to keep the capacitor lead length short.

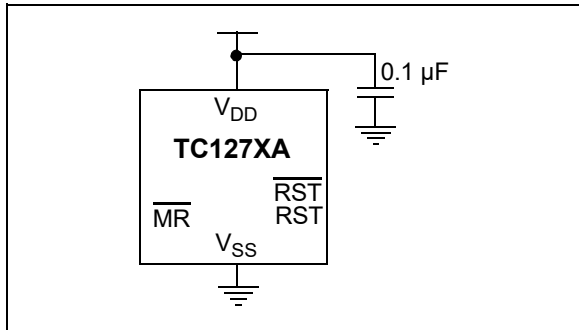

**FIGURE 5-1:** Typical Application Circuit with Bypass Capacitor.

### 5.2 Conventional Voltage Monitoring

Figure 5-2 and Figure 5-3 show the TC127XA in conventional voltage monitoring applications.

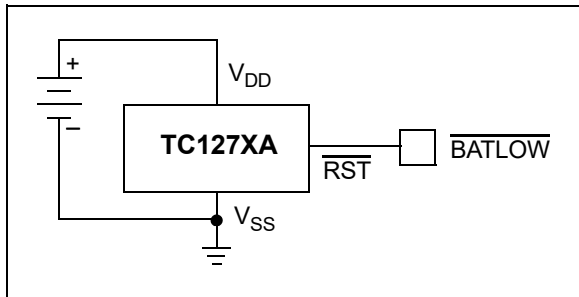

**FIGURE 5-2:** Battery Voltage Monitor.

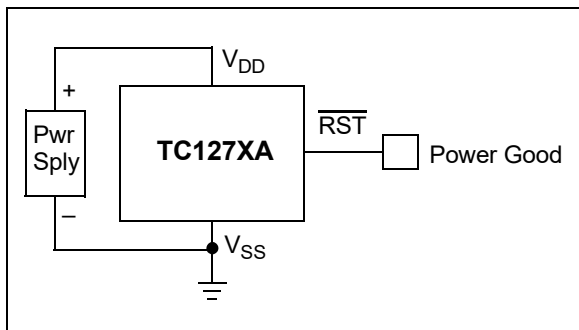

**FIGURE 5-3:** Power Good Monitor.

### 5.3 Using in PIC<sup>®</sup> Microcontroller, ICSP<sup>™</sup> Applications

**Note:** This operation can only be done using the device that has an Open-Drain  $\overline{\text{RST}}$  pin (TC1270AN).

Figure 5-4 shows the typical application circuit for using the TC1270AN for voltage supervisory function when the PIC microcontroller will be programmed via the In-Circuit Serial Programming<sup>™</sup> (ICSP<sup>™</sup>) feature. Additional information is available in the Microchip Technical Brief TB087, "Using Voltage Supervisors with PICmicro<sup>®</sup> Microcontroller Systems which Implement In-Circuit Serial Programming<sup>™</sup>" (DS91087).

**Note:** It is recommended that the current into the  $\overline{\text{RST}}$  pin is current that is limited by a 1 k $\Omega$  resistor.

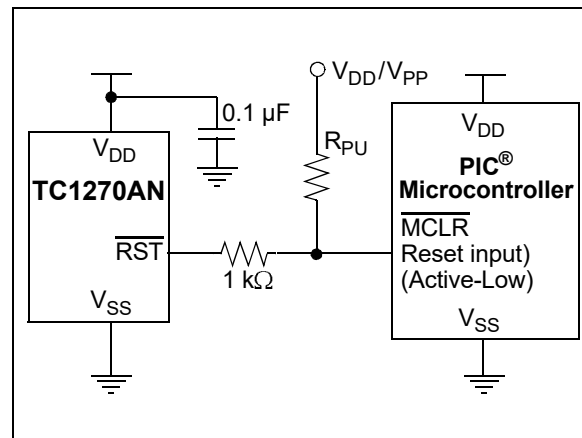

**FIGURE 5-4:** Typical Application Circuit for PIC Microcontroller with the ICSP Feature.

## 5.4 Modifying The Trip Point, $V_{TRIP}$

Although the TC127XA device has a fixed voltage trip point ( $V_{TRIP}$ ), it can be necessary to make custom adjustments. This is accomplished by connecting an external resistor divider to the TC127XA  $V_{DD}$  pin. This causes the  $V_{SOURCE}$  voltage to be higher than it is when the TC127XA input equals its  $V_{TRIP}$  voltage (Figure 5-5).

To maintain detector accuracy, the bleeder current through the divider should be significantly higher than the 15  $\mu$ A maximum operating current required by the TC127XA. A reasonable value for this bleeder current is 1 mA (67 times the 10  $\mu$ A required by the TC127XA). For example, if  $V_{TRIP} = 2V$  and the desired trip point is 2.5V, the value of  $R_1 + R_2$  is 2.5  $k\Omega$  (2.5V/1 mA). The value of  $R_1 + R_2$  can be rounded to the nearest standard value and plugged into the equation shown in Figure 5-5 to calculate values for  $R_1$  and  $R_2$ .

1% tolerance resistors are recommended.

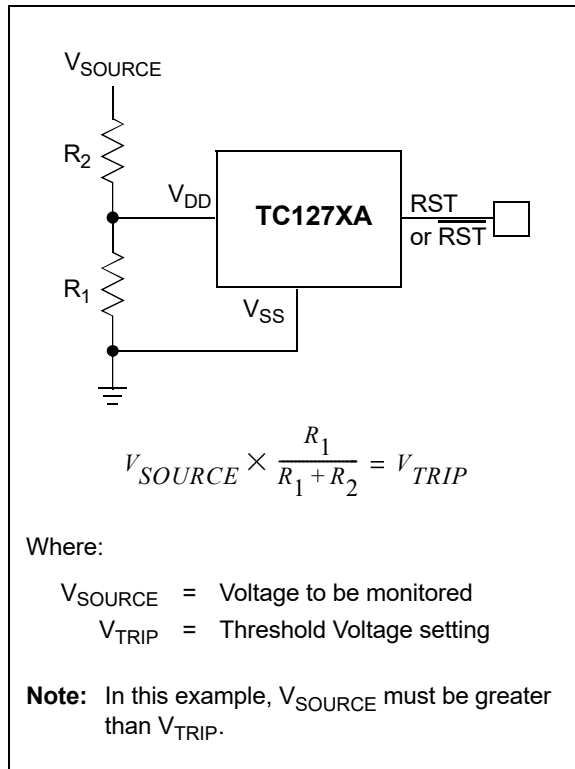

**FIGURE 5-5:** Modifying Trip-Point using External Resistor Divider.

## 5.5 MOSFET Low-Drive Protection

Low operating power and small physical size make the TC1270AN series ideal for many voltage detector applications. Figure 5-6 shows a low-voltage gate drive protection circuit that prevents the logic-level MOSFET from overheating due to insufficient gate voltage. When the input signal is below the threshold of the TC1270AN, its output grounds the gate of the MOSFET.

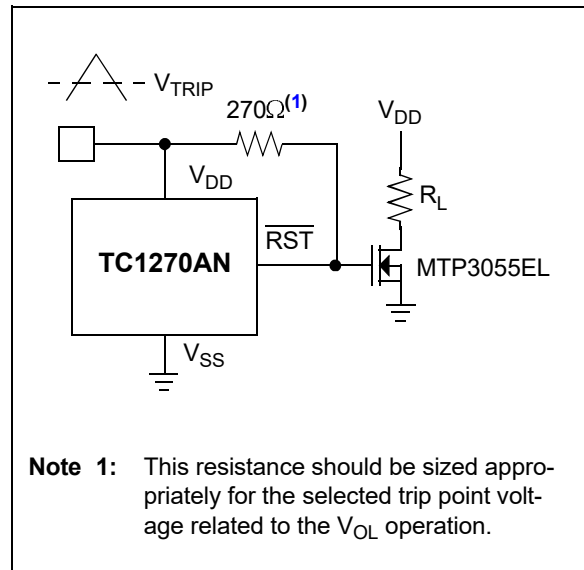
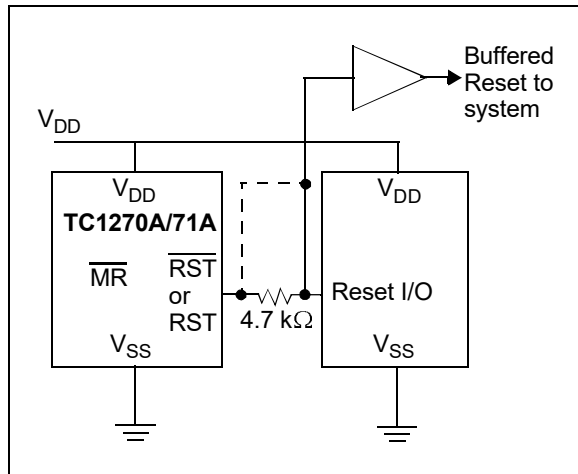

**FIGURE 5-6:** MOSFET Low-Drive Protection.

# TC1270A/70AN/71A

## 5.6 Controllers and Processors With Bidirectional I/O Pins

Some microcontrollers have bidirectional Reset pins. Depending on the current drive capability of the controller pin, an indeterminate logic level may result if there is a logic conflict. This can be avoided by adding a 4.7 kΩ resistor in series with the output of the TC127XA (Figure 5-7). If there are other components in the system that require a Reset signal, they should be buffered so as not to load the Reset line. If the other components are required to follow the Reset I/O of the microcontroller, the buffer should be connected as shown with the solid line.



**FIGURE 5-7:** Interfacing the TC1270A or TC1271A Push-Pull Output to a Bidirectional Reset I/O pin.

## 5.7 Migration Paths

Figure 5-8 shows the 5-pin SOT-23 footprint of the TC1270A, TC1270AN and TC1271A devices. Devices that are in the 3-pin SOT-23 package could be used in that circuit with the loss of manual Reset functionality. Examples of compatible footprint devices in the SOT-23-3 package are the MCP111, MCP112, TC54 and TC51 devices. This allows the system to be designed to offer a “base” functionality and a higher end system with the “enhanced” functionality, which includes a manual Reset.

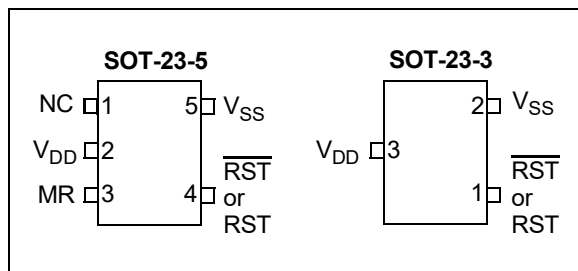

**FIGURE 5-8:** SOT-23 5-Pin to 3-Pin Comparison.

## 5.8 Reset Signal Integrity During Power-Down

The TC1270A and TC1271A Reset output is valid down to  $V_{DD} = 1.0V$ . Below this voltage the output becomes an “open circuit” and does not sink current. This means CMOS logic inputs to the microcontroller will be floating at an undetermined voltage. Most digital systems are completely shut down well above this voltage. However, in situations where the Reset signal must be maintained valid to  $V_{DD} = 0V$ , external circuitry is required.

For devices where the Reset signal is active-low, a pull-down resistor must be connected from the TC1270A RST pin to ground to discharge stray capacitances and hold the output low (Figure 5-9).

Similarly for devices where the Reset signal is active-high, a pull-up resistor to  $V_{DD}$  is required to ensure a valid high RST signal for  $V_{DD}$  below 1.0V (Figure 5-10).

This resistor value, though not critical, should be chosen such that it does not appreciably load the Reset pin under normal operation (100 kΩ should be suitable for most applications).

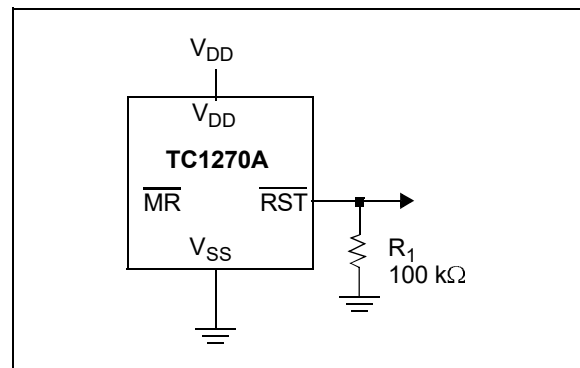

**FIGURE 5-9:** Ensuring a Valid Active-Low Reset Pin Output State as  $V_{DD}$  Approaches 0V.

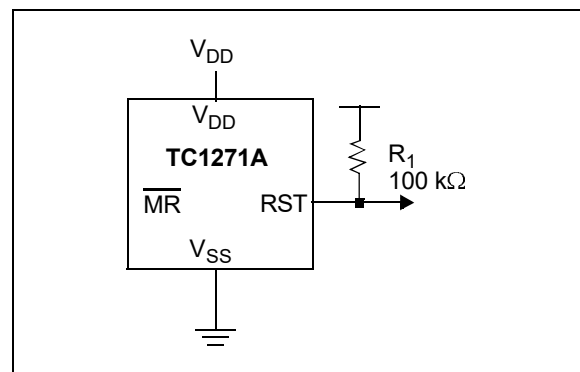

**FIGURE 5-10:** Ensuring a Valid Active-High Reset Pin Output State as  $V_{DD}$  Approaches 0V.

# TC1270A/70AN/71A

## 6.0 STANDARD DEVICES

Configurations can include the following options:

Table 6-1 shows the standard devices, with order numbers, as well as the corresponding configurations.

- Voltage Trip Point ( $V_{TRIP}$ )
- Reset Time Out ( $t_{RST}$ )

**TABLE 6-1: STANDARD VERSIONS**

Device	Reset Threshold (V)				Reset Time Out (ms)				Package	Order Number	Replaces
	Minimum	Typical	Maximum	Code	Minimum	Typical	Maximum	Code <sup>(1)</sup>			
TC1270A	4.50	4.63	4.75	L	140	280	560	"blank"	SOT-23-5	TC1270ALVCTTR	—
									SOT-143	TC1270ALVRCTR	TC1270LERC/ TCM811LERC
TC1270A	4.25	4.38	4.50	M	140	280	560	"blank"	SOT-23-5	TC1270AMVCTTR	—
									SOT-143	TC1270AMVRCTR	TC1270MERC/ TCM811MERC
TC1270A	3.00	3.08	3.15	T	140	280	560	"blank"	SOT-23-5	TC1270ATVCTTR	—
									SOT-143	TC1270ATVRCTR	TC1270TERC/ TCM811TERC
TC1270A	2.85	2.93	3.00	S	140	280	560	"blank"	SOT-23-5	TC1270ASVCTTR	—
									SOT-143	TC1270ASVRCTR	TC1270SERC/ TCM811SERC
TC1270A	2.55	2.63	2.70	R	140	280	560	"blank"	SOT-23-5	TC1270ARVCTTR	—
									SOT-143	TC1270ARVRCTR	TC1270RERC/ TCM811RERC
TC1270AN	4.50	4.63	4.75	L	140	280	560	"blank"	SOT-23-5	TC1270ANLVCTTR	—
									SOT-143	TC1270ANLVRCTR	—
TC1270AN	4.25	4.38	4.50	M	140	280	560	"blank"	SOT-23-5	TC1270ANMVCTTR	—
									SOT-143	TC1270ANMVRCTR	—
TC1270AN	3.00	3.08	3.15	T	140	280	560	"blank"	SOT-23-5	TC1270ANTVCTTR	—
									SOT-143	TC1270ANTVRCTR	—
TC1270AN	2.85	2.93	3.00	S	140	280	560	"blank"	SOT-23-5	TC1270ANSVCTTR	—
									SOT-143	TC1270ANSVRCTR	—
TC1270AN	2.55	2.63	2.70	R	140	280	560	"blank"	SOT-23-5	TC1270ANRVCTTR	—
									SOT-143	TC1270ANRVRCTR	—
TC1271A	4.50	4.63	4.75	L	140	280	560	"blank"	SOT-23-5	TC1271ALVCTTR	—
									SOT-143	TC1271ALVRCTR	TC1271LERC/ TCM812LERC
TC1271A	4.25	4.38	4.50	M	140	280	560	"blank"	SOT-23-5	TC1271AMVCTTR	—
									SOT-143	TC1271AMVRCTR	TC1271MERC/ TCM812MERC
TC1271A	3.00	3.08	3.15	T	140	280	560	"blank"	SOT-23-5	TC1271ATVCTTR	—
									SOT-143	TC1271ATVRCTR	TC1271TERC/ TCM812TERC
TC1271A	2.85	2.93	3.00	S	140	280	560	"blank"	SOT-23-5	TC1271ASVCTTR	—
									SOT-143	TC1271ASVRCTR	TC1271SERC/ TCM812SERC
TC1271A	2.55	2.63	2.70	R	140	280	560	"blank"	SOT-23-5	TC1271ARVCTTR	—
									SOT-143	TC1271ARVRCTR	TC1271RERC/ TCM812RERC

**Note 1:** "A" time-out delay options are only standard in the SOT-23-5 package. SOT-143 package is a custom request.

# TC1270A/70AN/71A

## 7.0 CUSTOM CONFIGURATIONS

The following Custom Reset Trip Point is available (see [Table 7-1](#)).

**TABLE 7-1: CUSTOM TRIP POINT**

Trip Voltage Selection	$V_{TRIP(MAX)}/V_{TRIP(MIN)}$	- % From Regulated Voltage
		3.0V
(1)	2.85V	5.0%
	2.70V	10.0%

**Note 1:** Contact your local Microchip sales office for additional information.

[Table 7-2](#) shows the codes that specify the desired Reset time out ( $t_{RST}$ ) for custom devices.

**TABLE 7-2: DELAY TIME OUT ORDERING CODES**

Code	Reset Delay Time (Typ) (ms)	Comment
A	35	<a href="#">Note 1</a>
B	2.19	<a href="#">Note 1</a>
"blank"	280	Delay timings for standard device offerings

**Note 1:** This delay timing option is not the standard offering. For information on ordering devices with these delay times, contact your local Microchip sales office. Minimum purchase volumes are required.

## 8.0 DEVELOPMENT TOOLS

### 8.1 Evaluation/Demonstration Boards

The SOT-23-5/6 Evaluation Board (VSUPEV2) can be used to evaluate the characteristics of the TC127XA devices.

This blank PCB has footprints for:

- Pull-up Resistor
- Pull-down Resistor
- Loading Capacitor
- In-line Resistor

There is also a power supply filtering capacitor.

For evaluating the TC127XA devices, the selected device should be installed into the Option A footprint.

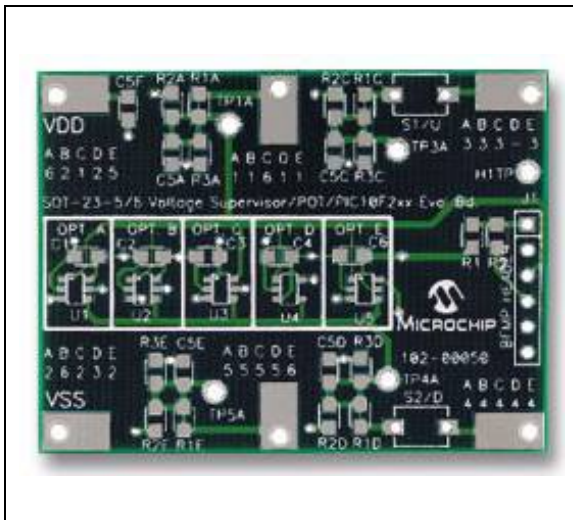

**FIGURE 8-1:** SOT-23-5/6 Voltage Supervisor Evaluation Board (VSUPEV2).

The SOIC-14 Evaluation Board (SOIC14EV) has a SOT-23-6 footprint that can be jumpered into any portion of the circuit. This will allow any footprint that the TC1270A requires in the SOT-23-5 package.

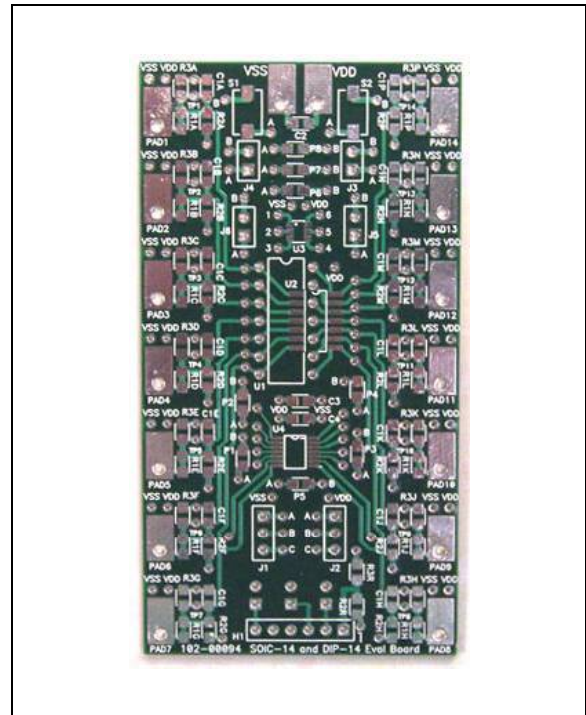

**FIGURE 8-2:** SOIC-14 Evaluation Board (Microchip Part Number SOIC14EV).

The PCB number, 102-00094, appears on the lower left side of the board. These evaluation boards can be purchased directly from the Microchip website at [www.microchip.com](http://www.microchip.com).



# TC1270A/70AN/71A

## 9.0 PACKAGING INFORMATION

### 9.1 Package Marking Information

5-Lead SOT-23

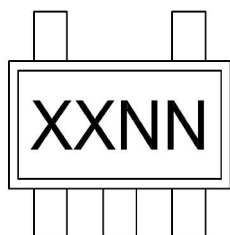

Part Number	Code	Part Number	Code
TC1270ALVCTTR	F1	TC1270ANLAVCTTR	H9
TC1270AMVCTTR	F2	TC1270ANRBVCTTR	PK
TC1270ATVCTTR	F3	TC1270ANSBVCTTR	PL
TC1270ASVCTTR	F4	TC1270ANTBVCTTR	PM
TC1270ARVCTTR	F5	TC1270ANMBVCTTR	PP
TC1270ARAVCTTR	G5	TC1270ANLBVCTTR	PQ
TC1270ASAVCTTR	G6	TC1271ALVCTTR	J1
TC1270ATAVCTTR	G7	TC1271AMVCTTR	J2
TC1270AMAVCTTR	G8	TC1271ATVCTTR	J3
TC1270ALAVCTTR	G9	TC1271ASVCTTR	J4
TC1270ARBVCTTR	LM	TC1271ARVCTTR	J5
TC1270ASBVCTTR	LP	TC1271ARAVCTTR	K5
TC1270ATBVCTTR	LQ	TC1271ASAVCTTR	K6
TC1270AMBVCTTR	LR	TC1271ATAVCTTR	K7
TC1270ALBVCTTR	LS	TC1271AMAVCTTR	K8
TC1270ANLVCTTR	FS	TC1271ALAVCTTR	K9
TC1270ANMVCTTR	FT	TC1271ARBVCTTR	RK
TC1270ANTVCTTR	FU	TC1271ASBVCTTR	RL
TC1270ANSVCTTR	FV	TC1271ATBVCTTR	RM
TC1270ANRVCTTR	FW	TC1271AMBVCTTR	RP
TC1270ANRAVCTTR	H5	TC1271ALBVCTTR	RQ
TC1270ANSVCTTR	H6	TC1270ASBVCTTRVAO	LP
TC1270ANTAVCTTR	H7	TC1270AMBVCTTR-VAO	LR
TC1270ANMAVCTTR	H8	TC1270ANSBVCTTR-VAO	PL

Example:

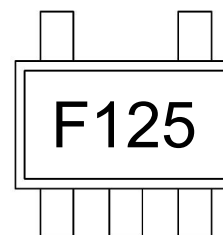

**Note:** The content of these tables applies to 5-Lead SOT-23.

<b>Legend:</b>	XX...X	Customer-specific information
	Y	Year code (last digit of calendar year)
	YY	Year code (last 2 digits of calendar year)
	WW	Week code (week of January 1 is week '01')
	NN	Alphanumeric traceability code
	(e3)	Pb-free JEDEC designator for Matte Tin (Sn)
	*	This package is Pb-free. The Pb-free JEDEC designator (e3) can be found on the outer packaging for this package.

**Note:** In the event the full Microchip part number cannot be marked on one line, it will be carried over to the next line, thus limiting the number of available characters for customer-specific information.

## Package Marking Information (Continued)

### 4-Lead SOT-143

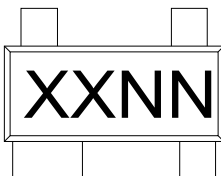

Part Number	Code	Part Number	Code
TC1270ALVRCTR	D1	TC1270ANMAVRCTR	E9
TC1270AMVRCTR	D2	TC1270ANLAVRCTR	EA
TC1270ATVRCTR	D3	TC1270ANRBVRCTR	EB
TC1270ASVRCTR	D4	TC1270ANSBVRCTR	EC
TC1270ARVRCTR	D5	TC1270ANTBVRCTR	ED
TC1270ARAVRCTR	D6	TC1270ANMBVRCTR	EE
TC1270ASAVRCTR	D7	TC1270ANLBVRCTR	EF
TC1270ATAVRCTR	D8	TC1271ALVRCTR	C1
TC1270AMAVRCTR	D9	TC1271AMVRCTR	C2
TC1270ALAVRCTR	DA	TC1271ATVRCTR	C3
TC1270ARBVRCTR	DB	TC1271ASVRCTR	C4
TC1270ASBVRCTR	DC	TC1271ARVRCTR	C5
TC1270ATBVRCTR	DD	TC1271ARAVRCTR	C6
TC1270AMBVRCTR	DE	TC1271ASAVRCTR	C7
TC1270ALBVRCTR	DF	TC1271ATAVRCTR	C8
TC1270ANLVRCTR	E1	TC1271AMAVRCTR	C9
TC1270ANMVRCTR	E2	TC1271ALAVRCTR	CA
TC1270ANTVRCTR	E3	TC1271ARBVRCTR	CB
TC1270ANSVRCTR	E4	TC1271ASBVRCTR	CC
TC1270ANRVRCTR	E5	TC1271ATBVRCTR	CD
TC1270ANRAVRCTR	E6	TC1271AMBVRCTR	CE
TC1270ANSAVRCTR	E7	TC1271ALBVRCTR	CF
TC1270ANTA VRCTR	E8	TC1270ARVRCTR-VAO	D5

### Example:

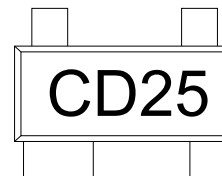

**Note:** The content of these tables applies to 4-Lead SOT-143.

**Legend:** XX...X Customer-specific information  
 Y Year code (last digit of calendar year)  
 YY Year code (last 2 digits of calendar year)  
 WW Week code (week of January 1 is week '01')  
 NN Alphanumeric traceability code  
 Ⓜ Pb-free JEDEC designator for Matte Tin (Sn)  
 \* This package is Pb-free. The Pb-free JEDEC designator (Ⓜ) can be found on the outer packaging for this package.

**Note:** In the event the full Microchip part number cannot be marked on one line, it will be carried over to the next line, thus limiting the number of available characters for customer-specific information.

# TC1270A/70AN/71A

## 5-Lead Plastic Small Outline Transistor (CT) [SOT23]

**Note:** For the most current package drawings, please see the Microchip Packaging Specification located at <http://www.microchip.com/packaging>

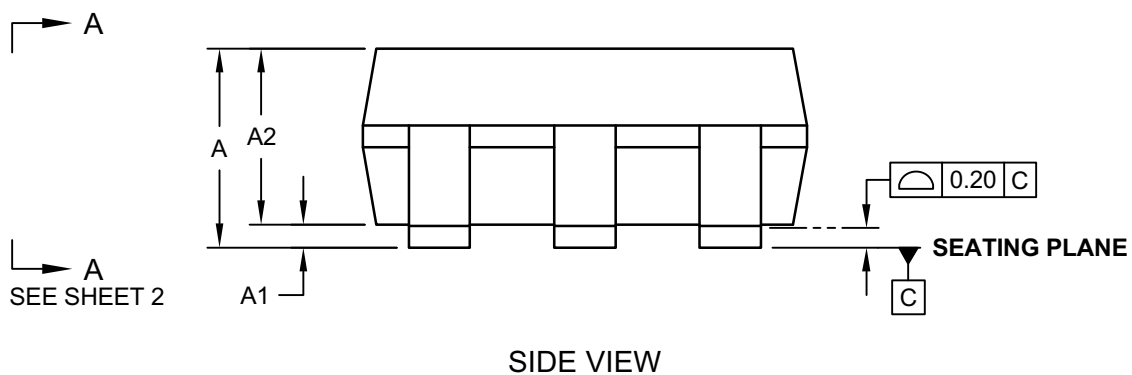
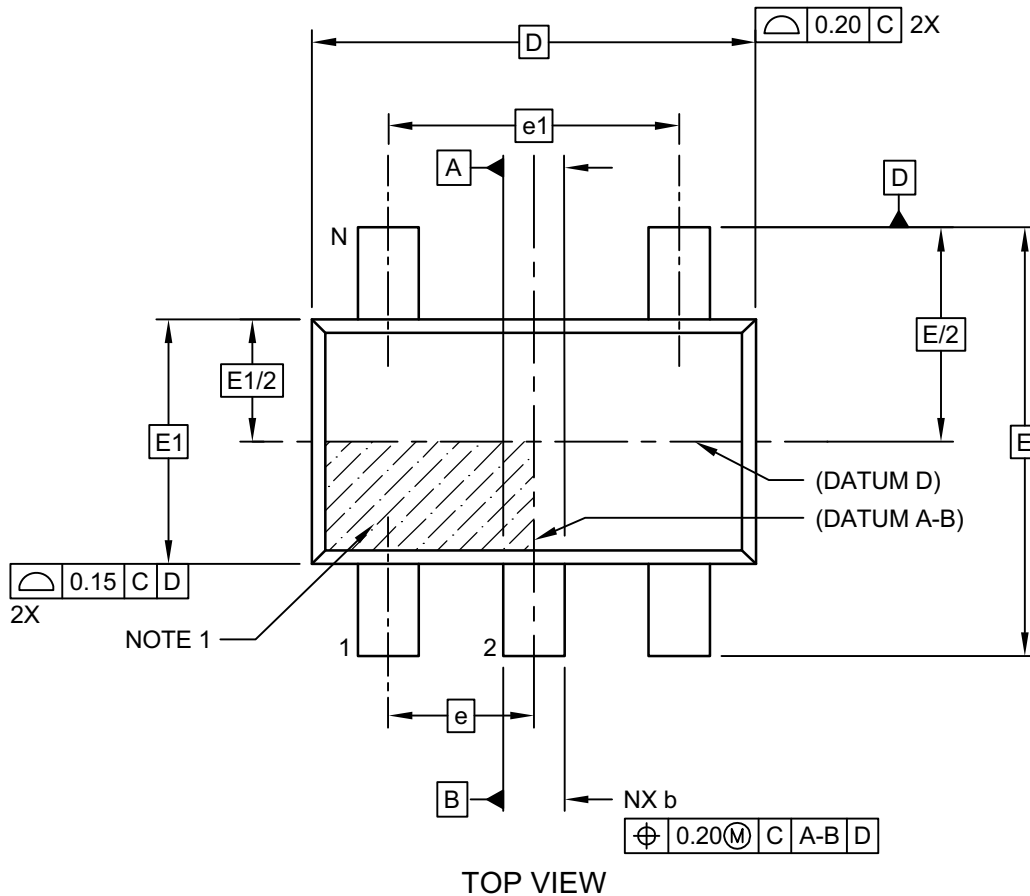

Microchip Technology Drawing C04-091-CT Rev F Sheet 1 of 2

# TC1270A/70AN/71A

## 5-Lead Plastic Small Outline Transistor (CT) [SOT23]

**Note:** For the most current package drawings, please see the Microchip Packaging Specification located at <http://www.microchip.com/packaging>

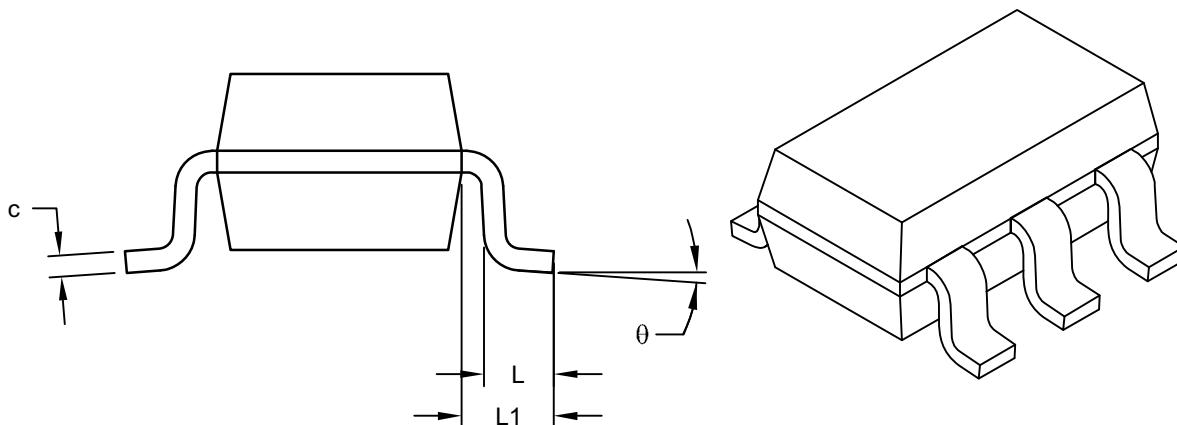

VIEW A-A  
SHEET 1

Dimension Limits	Units	MILLIMETERS		
		MIN	NOM	MAX
Number of Pins	N	5		
Pitch	e	0.95 BSC		
Outside lead pitch	e1	1.90 BSC		
Overall Height	A	0.90	-	1.45
Molded Package Thickness	A2	0.89	-	1.30
Standoff	A1	-	-	0.15
Overall Width	E	2.80 BSC		
Molded Package Width	E1	1.60 BSC		
Overall Length	D	2.90 BSC		
Foot Length	L	0.30	-	0.60
Footprint	L1	0.60 REF		
Foot Angle	$\phi$	0°	-	10°
Lead Thickness	c	0.08	-	0.26
Lead Width	b	0.20	-	0.51

Notes:

- Dimensions D and E1 do not include mold flash or protrusions. Mold flash or protrusions shall not exceed 0.25mm per side.
- Dimensioning and tolerancing per ASME Y14.5M  
BSC: Basic Dimension. Theoretically exact value shown without tolerances.  
REF: Reference Dimension, usually without tolerance, for information purposes only.

Microchip Technology Drawing C04-091-CT Rev F Sheet 2 of 2

# TC1270A/70AN/71A

## 5-Lead Plastic Small Outline Transistor (CT) [SOT23]

**Note:** For the most current package drawings, please see the Microchip Packaging Specification located at <http://www.microchip.com/packaging>

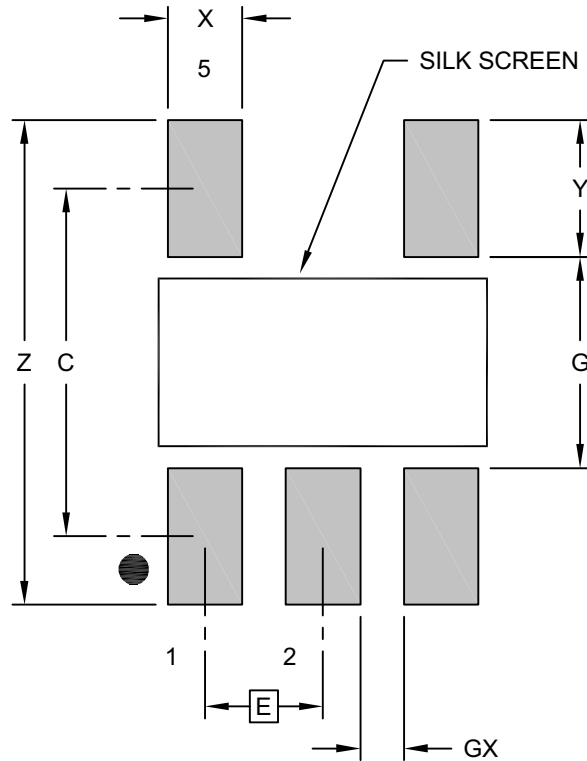

RECOMMENDED LAND PATTERN

Dimension Limits	Units	MILLIMETERS		
		MIN	NOM	MAX
Contact Pitch	E	0.95 BSC		
Contact Pad Spacing	C		2.80	
Contact Pad Width (X5)	X			0.60
Contact Pad Length (X5)	Y			1.10
Distance Between Pads	G	1.70		
Distance Between Pads	GX	0.35		
Overall Width	Z			3.90

**Notes:**

1. Dimensioning and tolerancing per ASME Y14.5M

BSC: Basic Dimension. Theoretically exact value shown without tolerances.

Microchip Technology Drawing No. C04-2091-CT Rev F

# TC1270A/70AN/71A

## 4-Lead Plastic Small Outline Transistor (RC) [SOT-143]

**Note:** For the most current package drawings, please see the Microchip Packaging Specification located at <http://www.microchip.com/packaging>

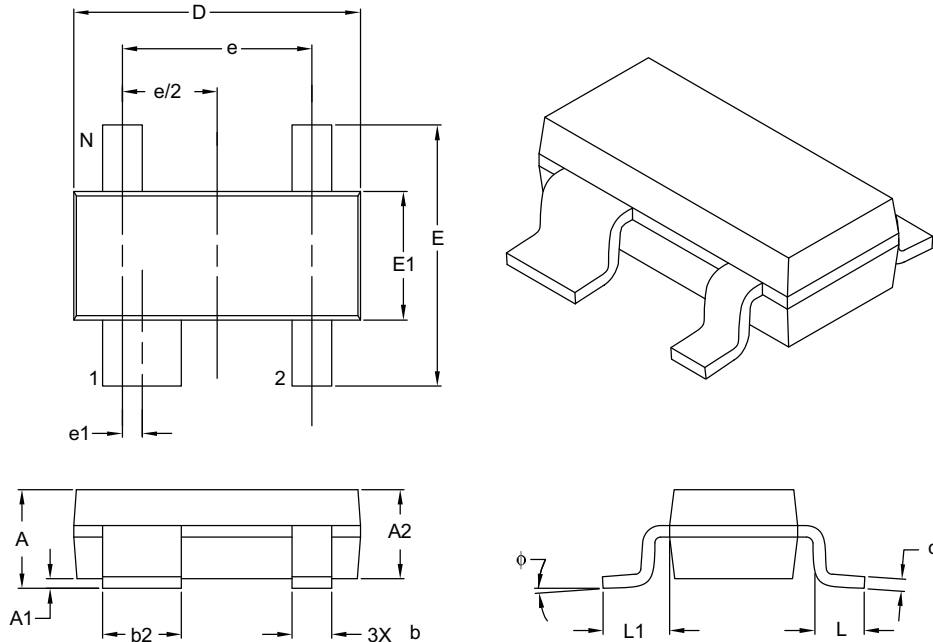

Dimension Limits	Units	MILLIMETERS		
		MIN	NOM	MAX
Number of Pins	N	4		
Pitch	e	1.92 BSC		
Lead 1 Offset	e1	0.20 BSC		
Overall Height	A	0.80	–	1.22
Molded Package Thickness	A2	0.75	0.90	1.07
Standoff §	A1	0.01	–	0.15
Overall Width	E	2.10	–	2.64
Molded Package Width	E1	1.20	1.30	1.40
Overall Length	D	2.67	2.90	3.05
Foot Length	L	0.13	0.50	0.60
Footprint	L1	0.54 REF		
Foot Angle	$\phi$	0°	–	8°
Lead Thickness	c	0.08	–	0.20
Lead 1 Width	b1	0.76	–	0.94
Leads 2, 3 & 4 Width	b	0.30	–	0.54

**Notes:**

- § Significant Characteristic.
- Dimensions D and E1 do not include mold flash or protrusions. Mold flash or protrusions shall not exceed 0.25 mm per side.
- Dimensioning and tolerancing per ASME Y14.5M.

BSC: Basic Dimension. Theoretically exact value shown without tolerances.

REF: Reference Dimension, usually without tolerance, for information purposes only.

Microchip Technology Drawing C04-031B

# TC1270A/70AN/71A

## 4-Lead Plastic Small Outline Transistor (RC) [SOT-143]

**Note:** For the most current package drawings, please see the Microchip Packaging Specification located at <http://www.microchip.com/packaging>

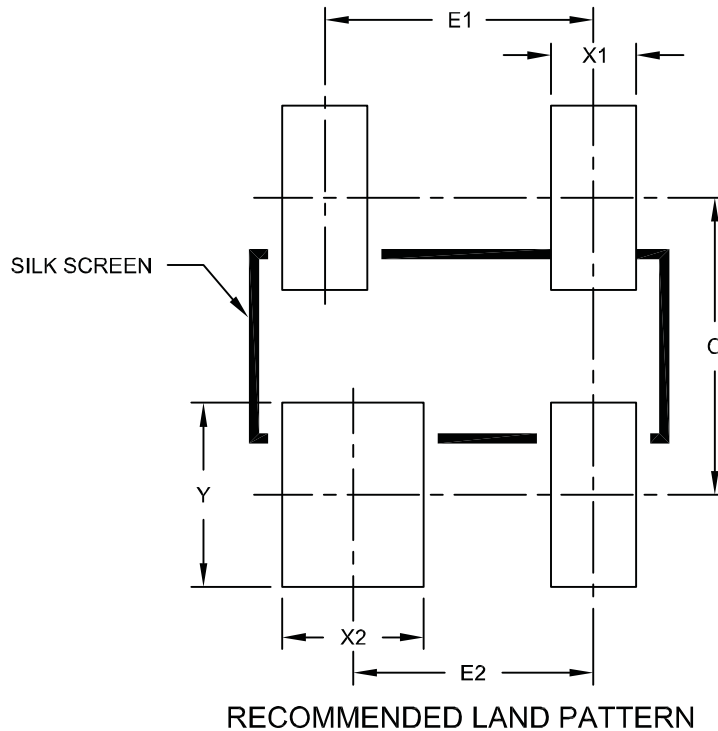

Dimension Limits	Units	MILLIMETERS		
		MIN	NOM	MAX
Contact Pitch	E1	1.90 BSC		
Contact Pitch	E2	1.60 BSC		
Contact Width	X1			0.60
Contact Width	X2			1.00
Contact Length	Y			1.30
Contact Pad Spacing	C		2.10	

**Notes:**

1. Dimensioning and tolerancing per ASME Y14.5M

BSC: Basic Dimension. Theoretically exact value shown without tolerances.

Microchip Technology Drawing No. C04-2031A

## 9.2 Product Tape and Reel Specifications

**FIGURE 9-1: EMBOSSED CARRIER DIMENSIONS (8 MM TAPE ONLY)**

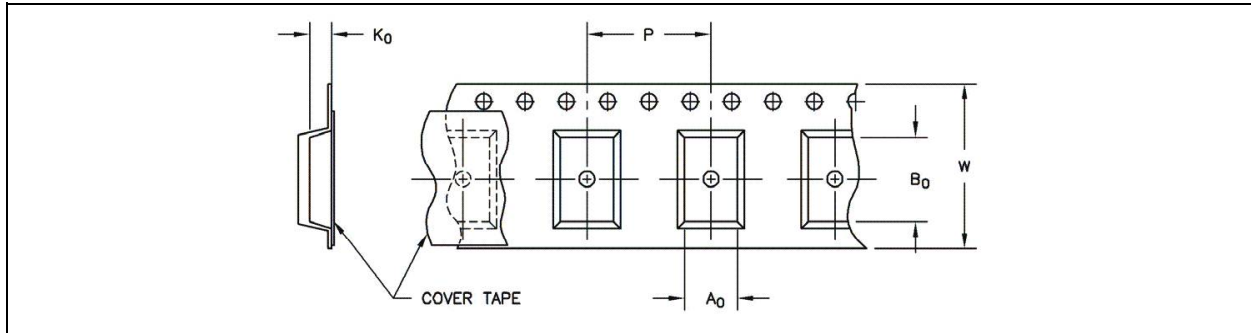

**TABLE 1: CARRIER TAPE/CAVITY DIMENSIONS**

Case Outline	Package Type		Carrier Dimensions		Cavity Dimensions			Output Quantity Units	Reel Diameter in mm
			W mm	P mm	A0 mm	B0 mm	K0 mm		
CT	SOT-23	5L	8	4	3.23	3.17	1.37	3000	180
RC	SOT-143	4L	8	4	3.1	2.69	1.3	3000	330

**FIGURE 9-2: 5-LEAD SOT-23 DEVICE TAPE AND REEL SPECIFICATIONS**

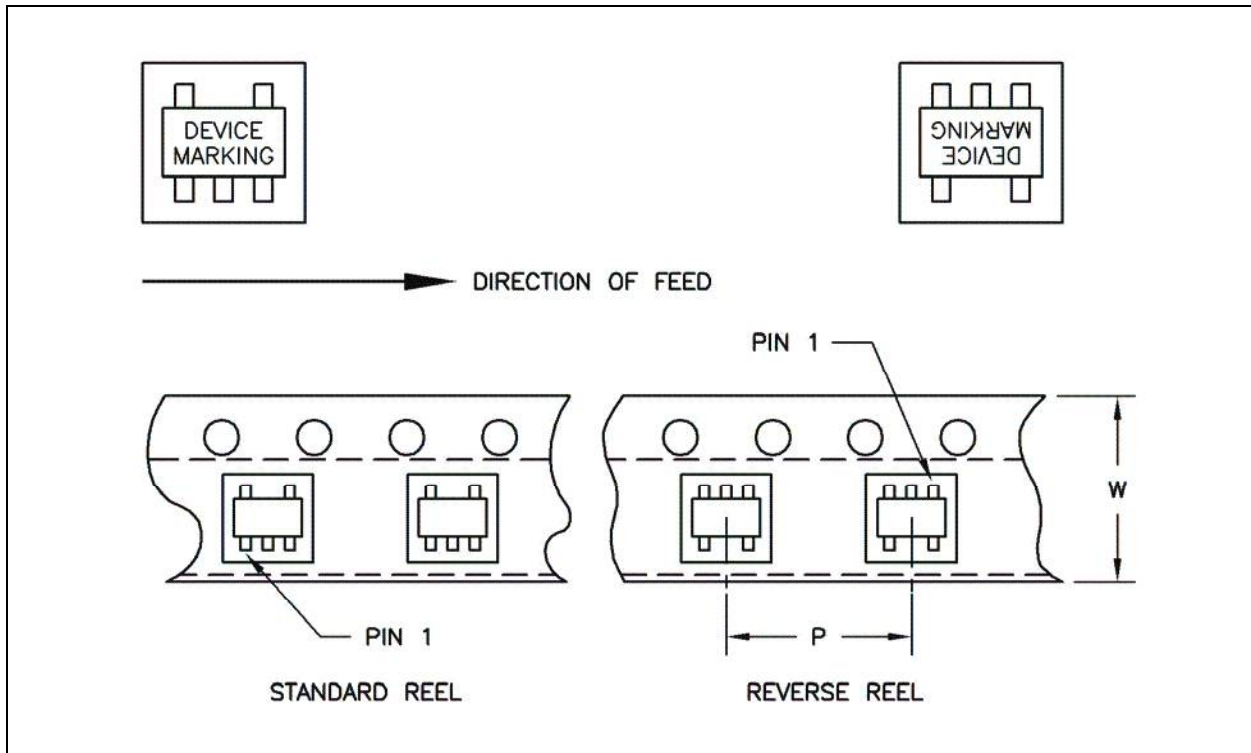



# TC1270A/70AN/71A

**FIGURE 9-3: 4-LEAD SOT-143 DEVICE TAPE AND REEL SPECIFICATIONS**

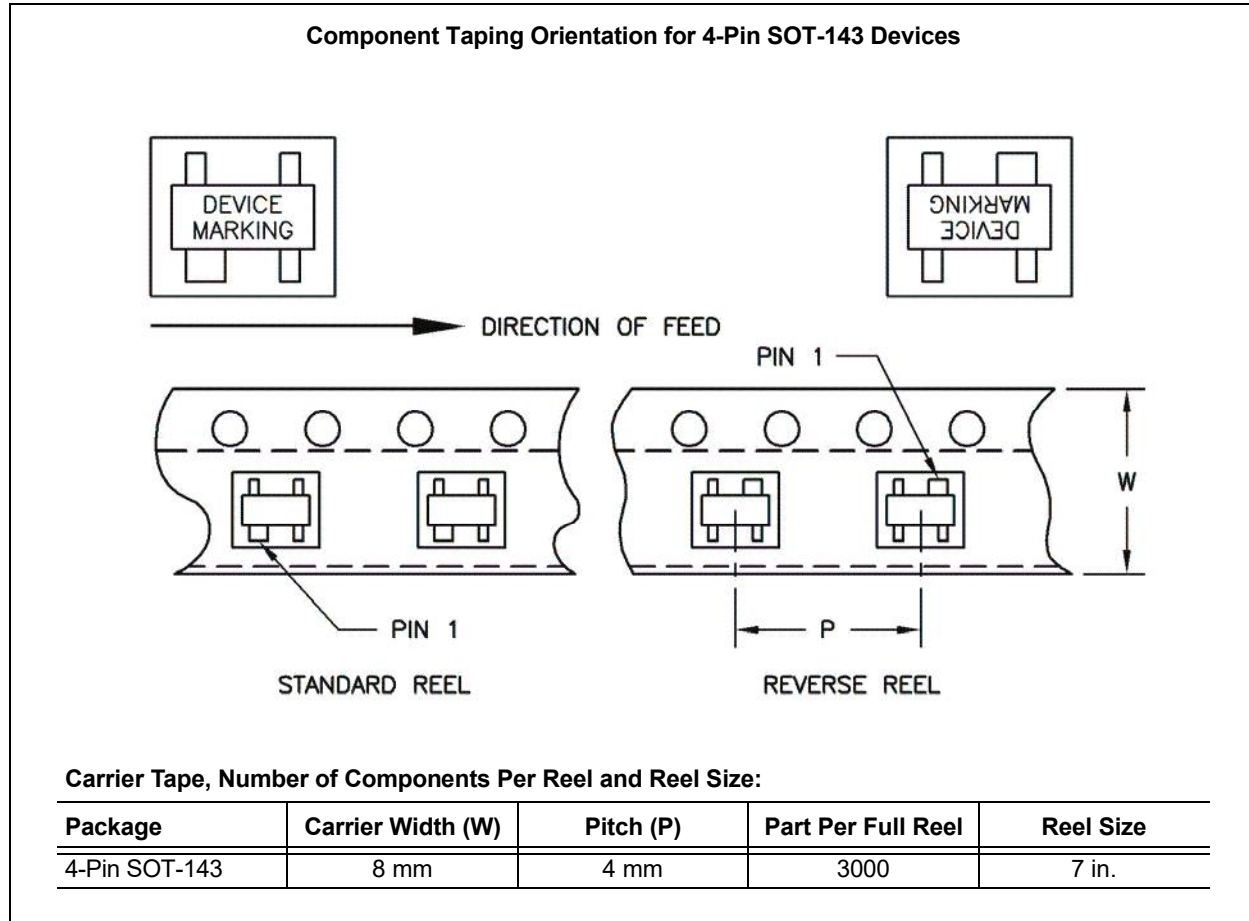

## APPENDIX A: REVISION HISTORY

### Revision F (January 2022)

- Updated Ground function pins in [Table 3-1](#).
- Updated document layout.
- Minor corrections throughout.
- Updated available variants lists in [Section 9.0 “Packaging information”](#).
- Updated [Product Identification System](#) to include Automotive information.

### Revision E (May 2021)

- Updated the [Features](#) section.
- Updated the [Temperature Characteristics](#) table.
- Updated [Section 9.0 “Packaging information”](#) with Automotive examples and current Package Drawings.
- Updated [Product Identification System](#) to include Automotive examples.
- Minor editorial corrections.

### Revision D (August 2011)

- Added the SOT-143 package to the TC1270AN device and related information throughout the document.

### Revision C (October 2010)

- Modified the [Product Identification System](#) section to reflect the custom manufacturing code used for devices with a Reset Delay time out of 35 ms (was a “C”, now is an “A”).
- Clarified information presented in [Section 4.2 “Voltage Detect Circuit”](#).

### Revision B (June 2007)

- Added new options:
  - Open-Drain output
  - New Reset Delay time outs.
- Updated Package Outline Drawings.
- Added new options to the [Product Identification System](#) section.

### Revision A (March 2007)

- Original Release of this Document.

NOTES:

# TC1270A/70AN/71A

## PRODUCT IDENTIFICATION SYSTEM

To order or obtain information, e.g., on pricing or delivery, refer to the factory or the listed sales office.

PART NO.	X	[X]	X	XX	TR <sup>(1)</sup>	-XXX	Examples:
Device	V <sub>TRIP</sub> Option	Reset Delay Option	Temp. Range	Package	Tape and Reel Option	Qualification	
<p><b>Device:</b></p> <p>TC1270A: Voltage Supervisor with Manual Reset            TC1270AN: Voltage Supervisor with Manual Reset            TC1271A: Voltage Supervisor with Manual Reset</p> <p><b>V<sub>TRIP</sub> Options:</b></p> <p>R = 2.55V (min.) / 2.63V (typ.) / 2.70V (max.)            S = 2.85V (min.) / 2.93V (typ.) / 3.00V (max.)            T = 3.00V (min.) / 3.08V (typ.) / 3.15V (max.)            M = 4.25V (min.) / 4.38V (typ.) / 4.50V (max.)            L = 4.50V (min.) / 4.63V (typ.) / 4.75V (max.)</p> <p><b>Reset Delay (Time-Out) Options:</b></p> <p>&lt;Blank&gt; = t<sub>RST</sub> = 280 ms (typ)            A = t<sub>RST</sub> = 35 ms (typ)            B = t<sub>RST</sub> = 2.19 ms (typ)</p> <p><b>Temperature Range:</b></p> <p>V = -40°C to +125°C</p> <p><b>Package:</b></p> <p>CT = Plastic Small Outline Transistor, SOT-23, 5-Lead            RC = Plastic Small Outline Transistor, SOT-143, 4-Lead</p> <p><b>Tape and Reel Option:</b></p> <p>TR = Tape and Reel<sup>(1)</sup></p> <p><b>Qualification:</b></p> <p>&lt;Blank&gt; = Standard Part            VAO = Automotive AEC-Q100 Qualified</p>							<p>a) TC1270ALBVRCTR:            4.50V min./4.63V typ./4.75V max. voltage trip point, Push-pull active-low Reset, Reset Delay Timer = 2.19 ms, -40°C to +125°C, 4-LD SOT-143, Tape and Reel</p> <p>b) TC1270AMAVRCTR:            4.25V min./4.38V typ./4.50V max. voltage trip point, Push-pull active-low Reset, Reset Delay Timer = 35 ms, -40°C to +125°C, 4-LD SOT-143, Tape and Reel</p> <p>c) TC1270ANRBVCTTR:            2.55V min./2.63V typ./2.70V max. voltage trip point, Open-drain active-low Reset, Reset Delay Timer = 2.19 ms, -40°C to +125°C, 5-Lead SOT-23, Tape and Reel</p> <p>d) TC1270ANLAVCTTR:            4.50V min./4.63V typ./4.75V max. voltage trip point, Open-drain active-low Reset, Reset Delay Timer = 35 ms, -40°C to +125°C, 5-Lead SOT-23, Tape and Reel</p> <p>e) TC1270ANTVRCTR:            3.00V min./3.08V typ./3.15V max. voltage trip point, Open-drain active-low Reset, Reset Delay Timer = 280 ms, -40°C to +125°C, 4-LD SOT-143, Tape and Reel</p> <p>f) TC1271ATVRCTR:            3.00V min./3.08V typ./3.15V max. voltage trip point, Push-pull active-high Reset, Reset Delay Timer = 280 ms, -40°C to +125°C, 4-LD SOT-143, Tape and Reel</p> <p>g) TC1271AMAVRCTR:            4.25V min./4.38V typ./4.50V max. voltage trip point, Push-pull active-high Reset, Reset Delay Timer = 35 ms, -40°C to +125°C, 4-LD SOT-143, Tape and Reel</p> <p>h) TC1271ASBVCTTR:            2.85V min./2.93V typ./3.00V max. voltage trip point, Push-pull active-high Reset, Reset Delay Timer = 2.19 ms, -40°C to +125°C, 5-LD SOT-23, Tape and Reel</p> <p>i) TC1270ASBVCTTR:            2.85V min./2.93V typ./3.00V max. voltage trip point, Push-pull active-low Reset, Reset Delay Timer = 2.19 ms, -40°C to +125°C, 5-LD SOT-23, Tape and Reel</p> <p>j) TC1270ARVRCTR-VAO:            2.55V min./2.63V typ./2.70V max. voltage trip point, Push-pull active-low Reset, Reset Delay Timer = 280 ms, -40°C to +125°C, 4-LD SOT-143, Tape and Reel, Automotive Qualified</p> <p><b>Note 1:</b> Tape and Reel identifier only appears in the catalog part number description. This identifier is used for ordering purposes and is not printed on the device package. Check with your Microchip Sales Office for package availability with the Tape and Reel option.</p>

# TC1270A/70AN/71A

---

NOTES:

---

---

**Note the following details of the code protection feature on Microchip products:**

- Microchip products meet the specifications contained in their particular Microchip Data Sheet.
- Microchip believes that its family of products is secure when used in the intended manner, within operating specifications, and under normal conditions.
- Microchip values and aggressively protects its intellectual property rights. Attempts to breach the code protection features of Microchip product is strictly prohibited and may violate the Digital Millennium Copyright Act.
- Neither Microchip nor any other semiconductor manufacturer can guarantee the security of its code. Code protection does not mean that we are guaranteeing the product is “unbreakable”. Code protection is constantly evolving. Microchip is committed to continuously improving the code protection features of our products.

---

This publication and the information herein may be used only with Microchip products, including to design, test, and integrate Microchip products with your application. Use of this information in any other manner violates these terms. Information regarding device applications is provided only for your convenience and may be superseded by updates. It is your responsibility to ensure that your application meets with your specifications. Contact your local Microchip sales office for additional support or, obtain additional support at <https://www.microchip.com/en-us/support/design-help/client-support-services>.

THIS INFORMATION IS PROVIDED BY MICROCHIP "AS IS". MICROCHIP MAKES NO REPRESENTATIONS OR WARRANTIES OF ANY KIND WHETHER EXPRESS OR IMPLIED, WRITTEN OR ORAL, STATUTORY OR OTHERWISE, RELATED TO THE INFORMATION INCLUDING BUT NOT LIMITED TO ANY IMPLIED WARRANTIES OF NON-INFRINGEMENT, MERCHANTABILITY, AND FITNESS FOR A PARTICULAR PURPOSE, OR WARRANTIES RELATED TO ITS CONDITION, QUALITY, OR PERFORMANCE.

IN NO EVENT WILL MICROCHIP BE LIABLE FOR ANY INDIRECT, SPECIAL, PUNITIVE, INCIDENTAL, OR CONSEQUENTIAL LOSS, DAMAGE, COST, OR EXPENSE OF ANY KIND WHATSOEVER RELATED TO THE INFORMATION OR ITS USE, HOWEVER CAUSED, EVEN IF MICROCHIP HAS BEEN ADVISED OF THE POSSIBILITY OR THE DAMAGES ARE FORESEEABLE. TO THE FULLEST EXTENT ALLOWED BY LAW, MICROCHIP'S TOTAL LIABILITY ON ALL CLAIMS IN ANY WAY RELATED TO THE INFORMATION OR ITS USE WILL NOT EXCEED THE AMOUNT OF FEES, IF ANY, THAT YOU HAVE PAID DIRECTLY TO MICROCHIP FOR THE INFORMATION.

Use of Microchip devices in life support and/or safety applications is entirely at the buyer's risk, and the buyer agrees to defend, indemnify and hold harmless Microchip from any and all damages, claims, suits, or expenses resulting from such use. No licenses are conveyed, implicitly or otherwise, under any Microchip intellectual property rights unless otherwise stated.

For information regarding Microchip's Quality Management Systems, please visit [www.microchip.com/quality](http://www.microchip.com/quality).

**Trademarks**

The Microchip name and logo, the Microchip logo, Adaptec, AnyRate, AVR, AVR logo, AVR Freaks, BesTime, BitCloud, CryptoMemory, CryptoRF, dsPIC, flexPWR, HELDO, IGLOO, JukeBlox, KeeLoq, Klear, LANCheck, LinkMD, maXStylus, maXTouch, MediaLB, megaAVR, Microsemi, Microsemi logo, MOST, MOST logo, MPLAB, OptoLyzer, PIC, picoPower, PICSTART, PIC32 logo, PolarFire, Prochip Designer, QTouch, SAM-BA, SenGenuity, SpyNIC, SST, SST Logo, SuperFlash, Symmetricom, SyncServer, Tachyon, TimeSource, tinyAVR, UNI/O, Vectron, and XMEGA are registered trademarks of Microchip Technology Incorporated in the U.S.A. and other countries.

AgileSwitch, APT, ClockWorks, The Embedded Control Solutions Company, EtherSynch, Flashtec, Hyper Speed Control, HyperLight Load, IntelliMOS, Libero, motorBench, mTouch, Powermite 3, Precision Edge, ProASIC, ProASIC Plus, ProASIC Plus logo, QuietWire, SmartFusion, SyncWorld, Temux, TimeCesium, TimeHub, TimePictra, TimeProvider, TrueTime, WinPath, and ZL are registered trademarks of Microchip Technology Incorporated in the U.S.A.

Adjacent Key Suppression, AKS, Analog-for-the-Digital Age, Any Capacitor, AnyIn, AnyOut, Augmented Switching, BlueSky, BodyCom, CodeGuard, CryptoAuthentication, CryptoAutomotive, CryptoCompanion, CryptoController, dsPICDEM, dsPICDEM.net, Dynamic Average Matching, DAM, ECAN, Espresso T1S, EtherGREEN, GridTime, IdealBridge, In-Circuit Serial Programming, ICSP, INICnet, Intelligent Paralleling, Inter-Chip Connectivity, JitterBlocker, Knob-on-Display, maxCrypto, maxView, memBrain, Mindi, MiWi, MPASM, MPF, MPLAB Certified logo, MPLIB, MPLINK, MultiTRAK, NetDetach, NVM Express, NVMe, Omniscient Code Generation, PICDEM, PICDEM.net, PICKit, PICtail, PowerSmart, PureSilicon, QMatrix, REAL ICE, Ripple Blocker, RTAX, RTG4, SAM-ICE, Serial Quad I/O, simpleMAP, SimpliPHY, SmartBuffer, SmartHLS, SMART-I.S., storClad, SQL, SuperSwitcher, SuperSwitcher II, Switchtec, SynchroPHY, Total Endurance, TSHARC, USBCheck, VariSense, VectorBlox, VeriPHY, ViewSpan, WiperLock, XpressConnect, and ZENA are trademarks of Microchip Technology Incorporated in the U.S.A. and other countries.

SQTP is a service mark of Microchip Technology Incorporated in the U.S.A.

The Adaptec logo, Frequency on Demand, Silicon Storage Technology, Symmcom, and Trusted Time are registered trademarks of Microchip Technology Inc. in other countries.

GestIC is a registered trademark of Microchip Technology Germany II GmbH & Co. KG, a subsidiary of Microchip Technology Inc., in other countries.

All other trademarks mentioned herein are property of their respective companies.

© 2007-2022, Microchip Technology Incorporated and its subsidiaries.

All Rights Reserved.

ISBN: 978-1-5224-9584-0



# MICROCHIP

## Worldwide Sales and Service

### AMERICAS

**Corporate Office**  
2355 West Chandler Blvd.  
Chandler, AZ 85224-6199  
Tel: 480-792-7200  
Fax: 480-792-7277  
Technical Support:  
<http://www.microchip.com/support>  
Web Address:  
[www.microchip.com](http://www.microchip.com)

#### Atlanta

Duluth, GA  
Tel: 678-957-9614  
Fax: 678-957-1455

#### Austin, TX

Tel: 512-257-3370

#### Boston

Westborough, MA  
Tel: 774-760-0087  
Fax: 774-760-0088

#### Chicago

Itasca, IL  
Tel: 630-285-0071  
Fax: 630-285-0075

#### Dallas

Addison, TX  
Tel: 972-818-7423  
Fax: 972-818-2924

#### Detroit

Novi, MI  
Tel: 248-848-4000

#### Houston, TX

Tel: 281-894-5983

#### Indianapolis

Noblesville, IN  
Tel: 317-773-8323  
Fax: 317-773-5453  
Tel: 317-536-2380

#### Los Angeles

Mission Viejo, CA  
Tel: 949-462-9523  
Fax: 949-462-9608  
Tel: 951-273-7800

#### Raleigh, NC

Tel: 919-844-7510

#### New York, NY

Tel: 631-435-6000

#### San Jose, CA

Tel: 408-735-9110  
Tel: 408-436-4270

#### Canada - Toronto

Tel: 905-695-1980  
Fax: 905-695-2078

### ASIA/PACIFIC

**Australia - Sydney**  
Tel: 61-2-9868-6733

**China - Beijing**  
Tel: 86-10-8569-7000

**China - Chengdu**  
Tel: 86-28-8665-5511

**China - Chongqing**  
Tel: 86-23-8980-9588

**China - Dongguan**  
Tel: 86-769-8702-9880

**China - Guangzhou**  
Tel: 86-20-8755-8029

**China - Hangzhou**  
Tel: 86-571-8792-8115

**China - Hong Kong SAR**  
Tel: 852-2943-5100

**China - Nanjing**  
Tel: 86-25-8473-2460

**China - Qingdao**  
Tel: 86-532-8502-7355

**China - Shanghai**  
Tel: 86-21-3326-8000

**China - Shenyang**  
Tel: 86-24-2334-2829

**China - Shenzhen**  
Tel: 86-755-8864-2200

**China - Suzhou**  
Tel: 86-186-6233-1526

**China - Wuhan**  
Tel: 86-27-5980-5300

**China - Xian**  
Tel: 86-29-8833-7252

**China - Xiamen**  
Tel: 86-592-2388138

**China - Zhuhai**  
Tel: 86-756-3210040

### ASIA/PACIFIC

**India - Bangalore**  
Tel: 91-80-3090-4444

**India - New Delhi**  
Tel: 91-11-4160-8631

**India - Pune**  
Tel: 91-20-4121-0141

**Japan - Osaka**  
Tel: 81-6-6152-7160

**Japan - Tokyo**  
Tel: 81-3-6880-3770

**Korea - Daegu**  
Tel: 82-53-744-4301

**Korea - Seoul**  
Tel: 82-2-554-7200

**Malaysia - Kuala Lumpur**  
Tel: 60-3-7651-7906

**Malaysia - Penang**  
Tel: 60-4-227-8870

**Philippines - Manila**  
Tel: 63-2-634-9065

**Singapore**  
Tel: 65-6334-8870

**Taiwan - Hsin Chu**  
Tel: 886-3-577-8366

**Taiwan - Kaohsiung**  
Tel: 886-7-213-7830

**Taiwan - Taipei**  
Tel: 886-2-2508-8600

**Thailand - Bangkok**  
Tel: 66-2-694-1351

**Vietnam - Ho Chi Minh**  
Tel: 84-28-5448-2100

### EUROPE

**Austria - Wels**  
Tel: 43-7242-2244-39  
Fax: 43-7242-2244-393

**Denmark - Copenhagen**  
Tel: 45-4485-5910  
Fax: 45-4485-2829

**Finland - Espoo**  
Tel: 358-9-4520-820

**France - Paris**  
Tel: 33-1-69-53-63-20  
Fax: 33-1-69-30-90-79

**Germany - Garching**  
Tel: 49-8931-9700

**Germany - Haan**  
Tel: 49-2129-3766400

**Germany - Heilbronn**  
Tel: 49-7131-72400

**Germany - Karlsruhe**  
Tel: 49-721-625370

**Germany - Munich**  
Tel: 49-89-627-144-0  
Fax: 49-89-627-144-44

**Germany - Rosenheim**  
Tel: 49-8031-354-560

**Israel - Ra'anana**  
Tel: 972-9-744-7705

**Italy - Milan**  
Tel: 39-0331-742611  
Fax: 39-0331-466781

**Italy - Padova**  
Tel: 39-049-7625286

**Netherlands - Drunen**  
Tel: 31-416-690399  
Fax: 31-416-690340

**Norway - Trondheim**  
Tel: 47-7288-4388

**Poland - Warsaw**  
Tel: 48-22-3325737

**Romania - Bucharest**  
Tel: 40-21-407-87-50

**Spain - Madrid**  
Tel: 34-91-708-08-90  
Fax: 34-91-708-08-91

**Sweden - Gothenberg**  
Tel: 46-31-704-60-40

**Sweden - Stockholm**  
Tel: 46-8-5090-4654

**UK - Wokingham**  
Tel: 44-118-921-5800  
Fax: 44-118-921-5820