



## Product Change Notification / SYST-09FRFM578

---

### Date:

10-Dec-2021

### Product Category:

Linear Regulators

### PCN Type:

Document Change

### Notification Subject:

Data Sheet - MCP1799 80 mA High-Voltage Automotive LDO Data Sheet Revision

### Affected CPNs:

[SYST-09FRFM578\\_Affected\\_CPN\\_12102021.pdf](#)

[SYST-09FRFM578\\_Affected\\_CPN\\_12102021.csv](#)

### Notification Text:

SYST-09FRFM578

Microchip has released a new Product Documents for the MCP1799 80 mA High-Voltage Automotive LDO Data Sheet of devices. If you are using one of these devices please read the document located at [MCP1799 80 mA High-Voltage Automotive LDO Data Sheet](#)

**Notification Status:** Final

**Description of Change:** Revision includes:

1. Updated Product Identification System to include automotive qualification information and examples.
2. Updated Section 7.0, Packaging Information layout and content.

**Impacts to Data Sheet:** See above details.

**Reason for Change:** To Improve Productivity

**Change Implementation Status:** Complete

**Date Document Changes Effective:** 10 December 2021

**NOTE:** Please be advised that this is a change to the document only the product has not been changed.

**Markings to Distinguish Revised from Unrevised Devices:** N/A

## **Attachments:**

[MCP1799 80 mA High-Voltage Automotive LDO Data Sheet](#)

Please contact your local [Microchip sales office](#) with questions or concerns regarding this notification.

## **Terms and Conditions:**

If you wish to receive Microchip PCNs via email please register for our PCN email service at our [PCN home page](#) select register then fill in the required fields. You will find instructions about registering for Microchips PCN email service in the [PCN FAQ](#) section.

If you wish to change your PCN profile, including opt out, please go to the [PCN home page](#) select login and sign into your myMicrochip account. Select a profile option from the left navigation bar and make the applicable selections.

Affected Catalog Part Numbers (CPN)

MCP1799T-5002H/TT  
MCP1799T-3302H/TT  
MCP1799T-5002H/TTV01  
MCP1799T-5002H/TTVAO  
MCP1799T-3302H/TTVAO  
MCP1799T-5002H/DB  
MCP1799T-3302H/DB  
MCP1799T-3302H/DBV02  
MCP1799T-5002H/DBVAO  
MCP1799T-3302H/DBVAO  
MCP1799-5002H/DB  
MCP1799-3302H/DB

## 80 mA High-Voltage Automotive LDO

### Features

- AEC-Q100 with Grade 0 and PPAP Capable
- Wide Input Voltage Range: 4.5V to 45V
  - Undervoltage Lockout (UVLO): 2.8V typical
- Extended Working Temperature Range: -40°C to +150°C
- Standard Output Regulated Voltages ( $V_R$ ): 3.3V and 5.0V
  - Tolerance  $\pm 2\%$
- Low Quiescent Supply Current: 25  $\mu\text{A}$  typical
- Output Current Capability: 80 mA typical
- Stable with 1  $\mu\text{F}$  Ceramic Output Capacitor
- Short Circuit Protection
- Thermal Shutdown Protection:
  - +180°C typical
  - Hysteresis: 22°C typical
- High Power Supply Rejection Ratio (PSRR):
  - 70 dB @ 1 kHz typical
- Available in the Following Packages:
  - 3-Lead SOT-23
  - 3-Lead SOT-223

### General Description

The MCP1799 is a high-voltage, Low-Dropout (LDO) regulator, capable of generating 80 mA output current. The input voltage range of 4.5V to 45V makes it ideal in 12V to 36V power rails and in high-voltage battery packs.

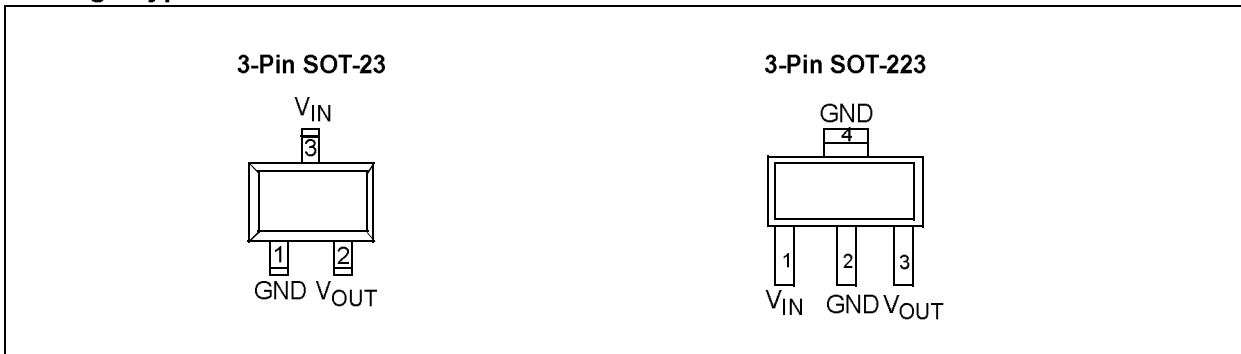
The MCP1799 comes in two standard fixed output-voltage versions: 3.3V and 5.0V. The regulator output is stable with 1  $\mu\text{F}$  ceramic capacitors. The device is protected from short circuit events by the current limit function and from over heating by means of thermal shutdown protection.

The device itself has a low ground current of 45  $\mu\text{A}$  typical, while delivering maximum output current of 80 mA. Without load the device consumes 25  $\mu\text{A}$  typical.

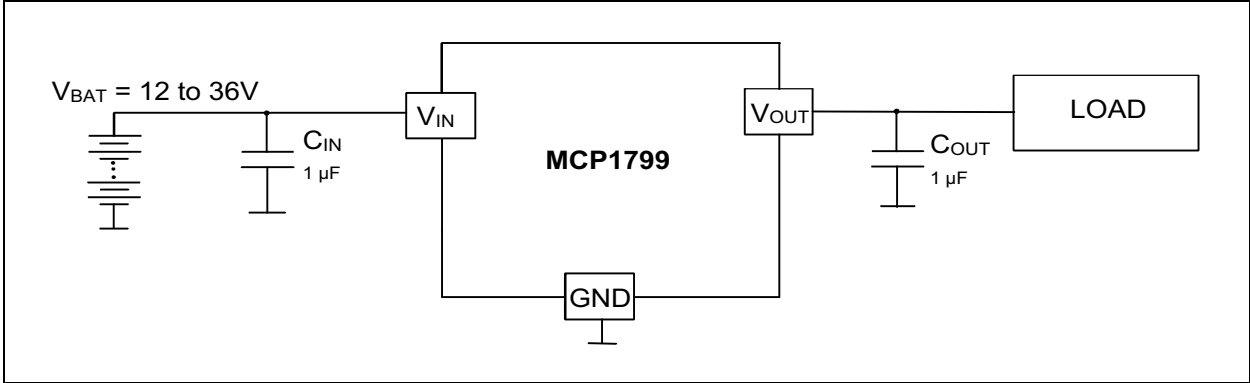
### Applications

- Automotive Electronics
- Microcontroller Biasing
- Cordless Power Tools, Home Appliances  
E-bikes, Drones, etc.
- Smoke Detectors and other Alarm Sensors

### Package Types



## Typical Application



## 1.0 ELECTRICAL CHARACTERISTICS

### Absolute Maximum Ratings (†)

Input Voltage .....	+66.0V
Maximum Voltage on $V_{IN}$ .....	(GND - 0.3V) to ( $V_{IN}+0.3V$ )
Maximum Voltage on $V_{OUT}$ .....	(GND - 0.3V) to 5.5V
Internal Power Dissipation .....	Internally-Limited ( <b>Note 3</b> )
Output Short Circuit Current .....	Continuous
Storage Temperature .....	-55°C to +175°C
Maximum Junction Temperature, $T_J$ .....	+185°C
Operating Junction Temperature, $T_J$ .....	-40°C to +150°C
ESD protection on all pins:	
HBM .....	≥ 4 kV
CDM .....	≥ 750V
MM .....	≥ 400V

† **Notice:** Stresses above those listed under "Absolute Maximum Ratings" may cause permanent damage to the device. This is a stress rating only and functional operation of the device at those or any other conditions above those indicated in the operational listings of this specification is not intended. Exposure to maximum rating conditions for extended periods may affect device reliability.

### AC/DC CHARACTERISTICS

**Electrical Specifications:** Unless otherwise noted,  $V_{IN} = 6.2V$ (for  $V_R = 5V$ ),  $V_{IN} = 4.5V$ (for  $V_R = 3.3V$ ),  $I_{OUT} = 1$  mA,  $C_{IN} = C_{OUT} = 1.0$   $\mu F$  ceramic (X7R),  $T_A = +25^\circ C$ . **Boldface** type applies for ambient temperatures  $T_A$  of  $-40^\circ C$  to  $+150^\circ C$ .

Parameters	Symbol	Min.	Typ.	Max.	Units	Conditions
Input Operating Voltage	$V_{IN}$	<b>4.5</b>	—	<b>45</b>	V	$V_R = 3.3V, I_{OUT} \leq 80$ mA
		<b>6.2</b>	—	<b>45</b>		$V_R = 5V, I_{OUT} \leq 80$ mA
Input Voltage to Turn On Output	$V_{UVLO\_High}$	—	2.8	—	V	rising $V_{IN}$ , $V_{IN} = 0$ to $V_{IN(MIN)}$
Input Voltage to Turn Off Output	$V_{UVLO\_Low}$	—	2.6	—		falling $V_{IN}$ , $V_{IN} = V_{IN(MIN)}$ to 0
Output Voltage Range	$V_{OUT}$	<b><math>V_R-2\%</math></b>	$V_R$	<b><math>V_R+2\%</math></b>		<b>(Note 1)</b>
Input Quiescent Current	$I_Q$	—	25	<b>45</b>	$\mu A$	$I_{OUT} = 0A$
Ground Current	$I_{GND}$	—	45	<b>110</b>	$\mu A$	$I_{OUT} = 80$ mA
Maximum Output Current	$I_{OUT}$	<b>80</b>	—	—	mA	<b>(Note 3)</b>
Line Regulation	$\frac{\Delta V_{OUT}}{V_{OUT} \times \Delta V_{IN}}$	<b>-0.05</b>	$\pm 0.02$	<b>+0.05</b>	%/V	$4.5V \leq V_{IN} \leq 45V$ for $V_R = 3.3V$ $6.2V \leq V_{IN} \leq 45V$ for $V_R = 5V$

**Note 1:**  $V_R$  is the nominal regulator output voltage.

**2:** Load regulation is measured at a constant ambient temperature using a DC current source. Load regulation is tested over a load range 1 mA to the maximum specified output current.

**3:** The maximum allowable power dissipation is a function of ambient temperature, the maximum allowable junction temperature and the thermal resistance from junction to air. (i.e.,  $T_A$ ,  $T_J$ ,  $\theta_{JA}$ ). See [Section "Temperature Specifications"](#) for more information. Exceeding the maximum allowable power dissipation will cause the device operating junction temperature to exceed the maximum +150°C rating. Sustained junction temperatures above +150°C might impact the device reliability.

**4:** Dropout voltage is defined as the input-to-output voltage differential at which the output voltage drops 2% below its nominal value that was measured with an input voltage of  $V_{IN} = V_R + 1.2V$ .

**5:** PSRR measurement is carried out with  $C_{IN} = 0$   $\mu F$ ,  $V_{IN} = 7V$ ,  $I_{OUT} = 50$  mA,  $V_{INAC} = 0.4V_{pkpk}$

**6:** Not production tested.

## AC/DC CHARACTERISTICS (CONTINUED)

**Electrical Specifications:** Unless otherwise noted,  $V_{IN} = 6.2V$  (for  $V_R = 5V$ ),  $V_{IN} = 4.5V$  (for  $V_R = 3.3V$ ),  $I_{OUT} = 1\text{ mA}$ ,  $C_{IN} = C_{OUT} = 1.0\text{ }\mu\text{F}$  ceramic (X7R),  $T_A = +25^\circ\text{C}$ . **Boldface** type applies for ambient temperatures  $T_A$  of  $-40^\circ\text{C}$  to  $+150^\circ\text{C}$ .

Parameters	Symbol	Min.	Typ.	Max.	Units	Conditions
Load Regulation	$\Delta V_{OUT}/V_{OUT}$	<b>-0.8</b>	$\pm 0.4$	<b>+0.8</b>	%	$I_{OUT} = 1\text{ mA}$ to $80\text{ mA}$ ( <b>Note 2</b> )
Output Current Limit	$I_{OUT\_CL}$	—	150	<b>215</b>	mA	$V_{IN} = V_{IN(MIN)}$ , $V_{OUT} > 0.1V$ , ( <b>Note 6</b> )
Output Peak Current Limit	$I_{OUT\_PCL}$		1700	<b>2500</b>	mA	
Dropout Voltage	$V_{DROPOUT}$	—	300	<b>1100</b>	mV	$I_{OUT} = 80\text{ mA}$ ( <b>Note 4</b> )
AC Performance						
Output Noise	$e_N$	—	500	—	$\mu\text{Vrms}$	$f = 100\text{ Hz}$ to $100\text{ kHz}$ $V_{IN} = 12V$ , $V_R = 5V$ $I_{OUT} = 10\text{ mA}$ ( <b>Note 6</b> )
Power Supply Ripple Rejection Ratio	PSRR	—	70	—	dB	$f = 100\text{ Hz}$ ( <b>Note 5</b> ) ( <b>Note 6</b> )
			70			$f = 1\text{ kHz}$ ( <b>Note 5</b> ) ( <b>Note 6</b> )
			35			$f = 100\text{ kHz}$ ( <b>Note 5</b> ) ( <b>Note 6</b> )

**Note 1:**  $V_R$  is the nominal regulator output voltage.

**2:** Load regulation is measured at a constant ambient temperature using a DC current source. Load regulation is tested over a load range  $1\text{ mA}$  to the maximum specified output current.

**3:** The maximum allowable power dissipation is a function of ambient temperature, the maximum allowable junction temperature and the thermal resistance from junction to air. (i.e.,  $T_A$ ,  $T_J$ ,  $\theta_{JA}$ ). See [Section "Temperature Specifications"](#) for more information. Exceeding the maximum allowable power dissipation will cause the device operating junction temperature to exceed the maximum  $+150^\circ\text{C}$  rating. Sustained junction temperatures above  $+150^\circ\text{C}$  might impact the device reliability.

**4:** Dropout voltage is defined as the input-to-output voltage differential at which the output voltage drops 2% below its nominal value that was measured with an input voltage of  $V_{IN} = V_R + 1.2V$ .

**5:** PSRR measurement is carried out with  $C_{IN} = 0\text{ }\mu\text{F}$ ,  $V_{IN} = 7V$ ,  $I_{OUT} = 50\text{ mA}$ ,  $V_{INAC} = 0.4V_{pkpk}$

**6:** Not production tested.

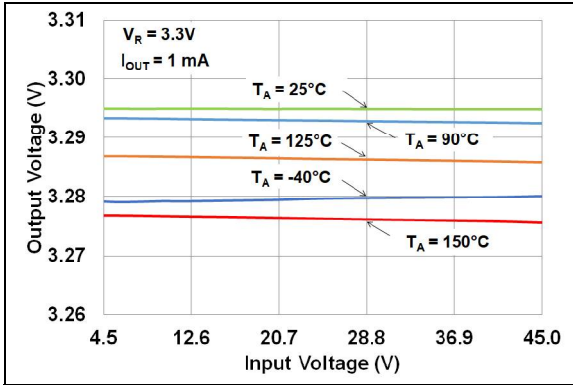
## TEMPERATURE SPECIFICATIONS

Parameters	Symbol	Min.	Typ.	Max.	Units	Conditions
Temperature Ranges						
Thermal Shutdown	$T_{SD}$		180		$^\circ\text{C}$	Rising Temperature
Thermal Shutdown Hysteresis	$\Delta T_{SD}$	—	22		$^\circ\text{C}$	Falling Temperature
Thermal Package Resistances						
Thermal Resistance, SOT23-3LD	$\theta_{JA}$	—	212	—	$^\circ\text{C/W}$	JEDEC <sup>®</sup> standard 4 layer FR4 board with 1 oz. copper
	$\theta_{JC}$	—	139	—		
Thermal Resistance, SOT223-3LD	$\theta_{JA}$	—	70	—		
	$\theta_{JC}$	—	60	—		

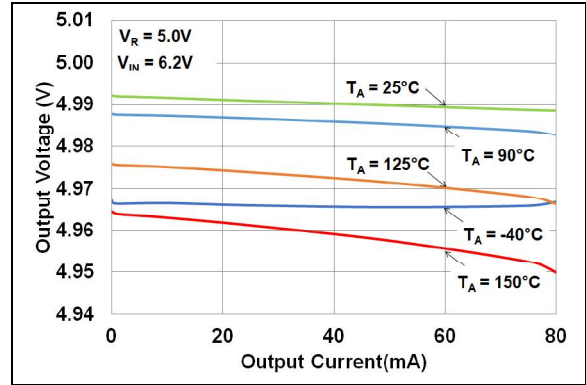
## 2.0 TYPICAL PERFORMANCE CURVES

**Note:** The graphs and tables provided following this note are a statistical summary based on a limited number of samples and are provided for informational purposes only. The performance characteristics listed herein are not tested or guaranteed. In some graphs or tables, the data presented may be outside the specified operating range (e.g., outside specified power supply range) and therefore outside the warranted range.

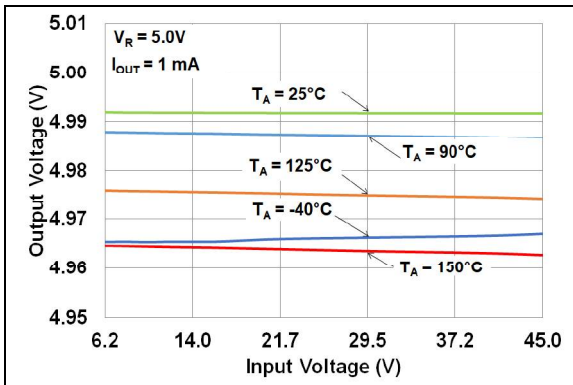
**Note:** Unless otherwise indicated,  $C_{IN} = C_{OUT} = 1 \mu\text{F}$  ceramic (X7R),  $I_{OUT} = 1 \text{ mA}$ ,  $T_A = +25^\circ\text{C}$ ,  $V_{IN} = V_R + 1.2\text{V}$ .



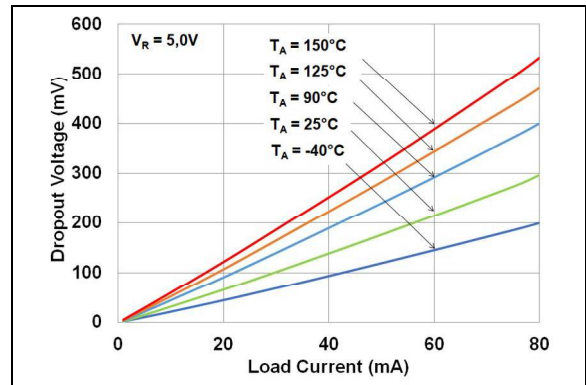
**FIGURE 2-1:** Output Voltage vs. Input Voltage ( $V_R = 3.3\text{V}$ ).



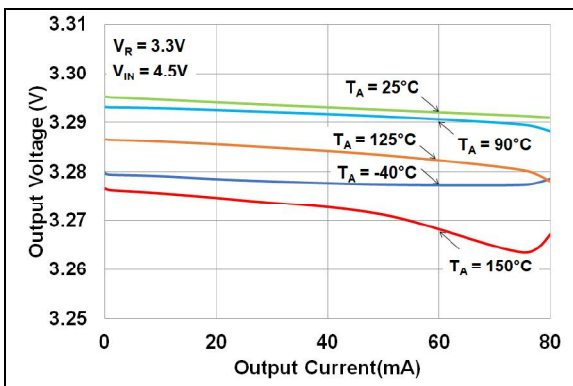
**FIGURE 2-4:** Output Voltage vs. Output Current ( $V_R = 5.0\text{V}$ ).



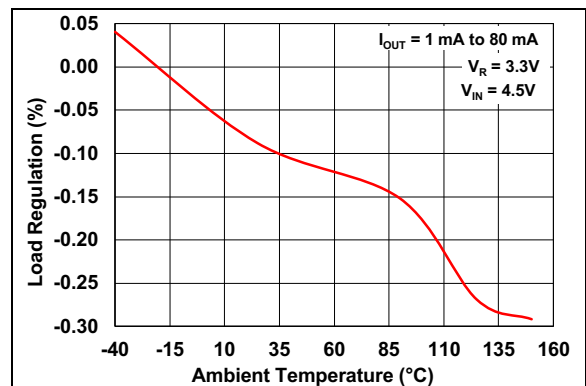
**FIGURE 2-2:** Output Voltage vs. Input Voltage ( $V_R = 5.0\text{V}$ ).



**FIGURE 2-5:** Dropout Voltage vs. Output Current.



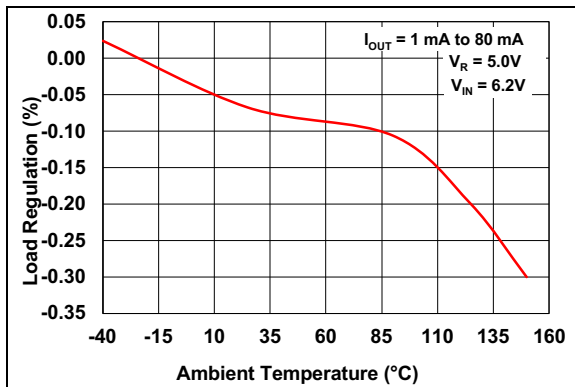
**FIGURE 2-3:** Output Voltage vs. Output Current ( $V_R = 3.3\text{V}$ ).



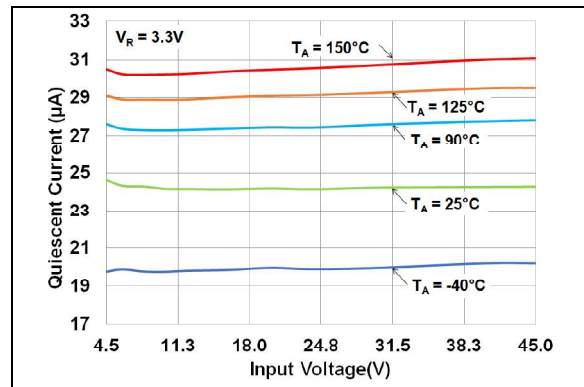
**FIGURE 2-6:** Load Regulation vs. Ambient Temperature ( $V_R = 3.3\text{V}$ ).



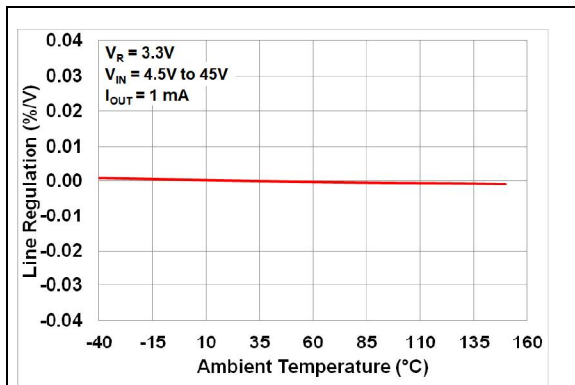
**Note:** Unless otherwise indicated,  $C_{IN} = C_{OUT} = 1 \mu\text{F}$  ceramic (X7R),  $I_{OUT} = 1 \text{ mA}$ ,  $T_A = +25^\circ\text{C}$ ,  $V_{IN} = V_R + 1.2\text{V}$ .



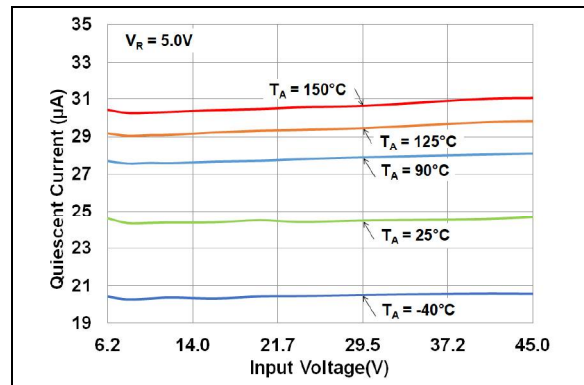
**FIGURE 2-7:** Load Regulation vs. Ambient Temperature ( $V_R = 5.0\text{V}$ ).



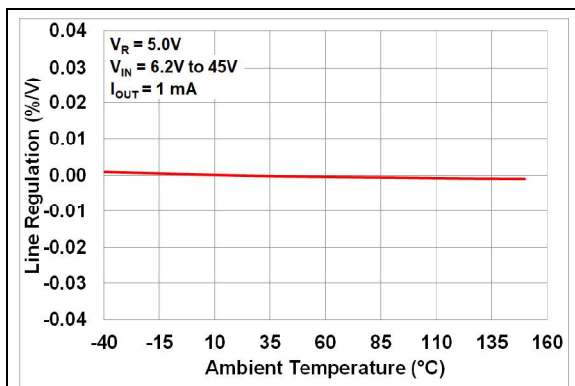
**FIGURE 2-10:** Quiescent Current vs. Input Voltage ( $V_R = 3.3\text{V}$ ).



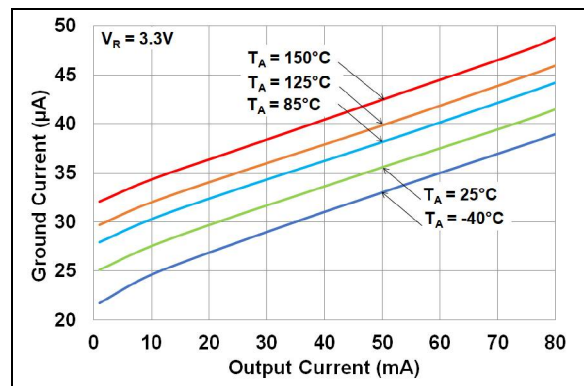
**FIGURE 2-8:** Line Regulation vs. Ambient Temperature ( $V_R = 3.3\text{V}$ ).



**FIGURE 2-11:** Quiescent Current vs. Input Voltage ( $V_R = 5.0\text{V}$ ).

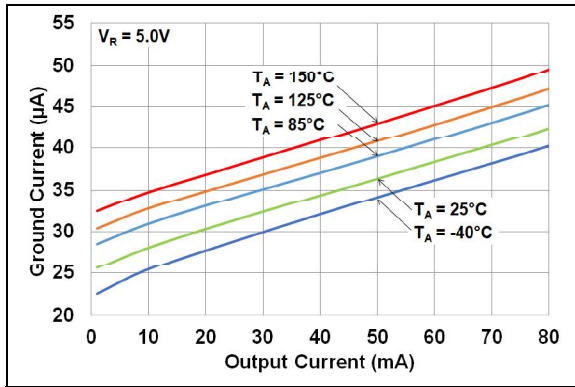


**FIGURE 2-9:** Line Regulation vs. Ambient Temperature ( $V_R = 5.0\text{V}$ ).

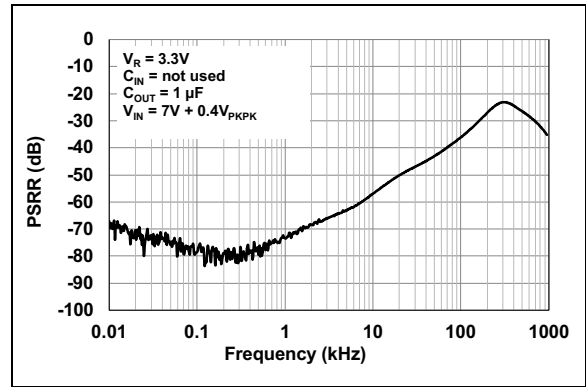


**FIGURE 2-12:** Ground Current vs. Output Current ( $V_R = 3.3\text{V}$ ).

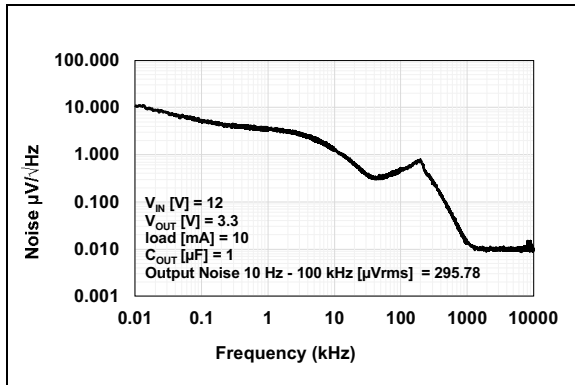
**Note:** Unless otherwise indicated,  $C_{IN} = C_{OUT} = 1 \mu\text{F}$  ceramic (X7R),  $I_{OUT} = 1 \text{ mA}$ ,  $T_A = +25^\circ\text{C}$ ,  $V_{IN} = V_R + 1.2\text{V}$ .



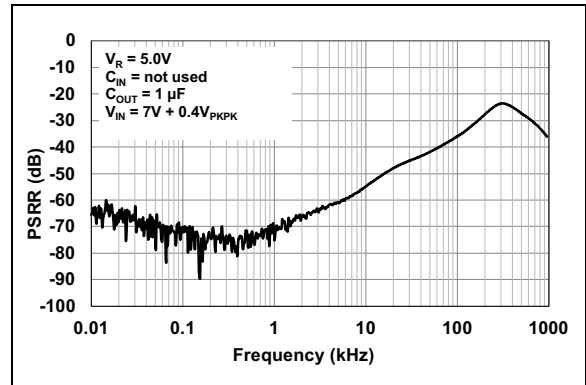
**FIGURE 2-13:** Ground Current vs. Output Current ( $V_R = 5.0\text{V}$ ).



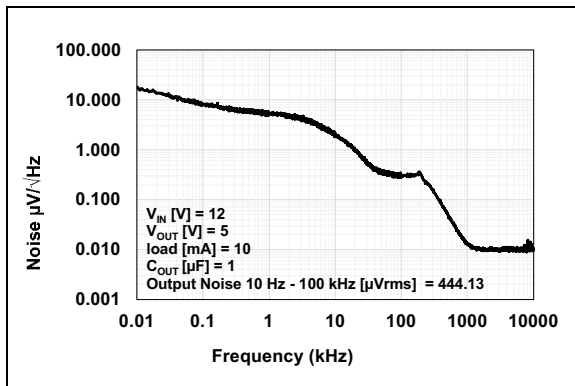
**FIGURE 2-16:** Power Supply Ripple Rejection Ratio vs. Frequency ( $V_R = 3.3\text{V}$ ).



**FIGURE 2-14:** Noise vs. Frequency ( $V_R = 3.3\text{V}$ ).

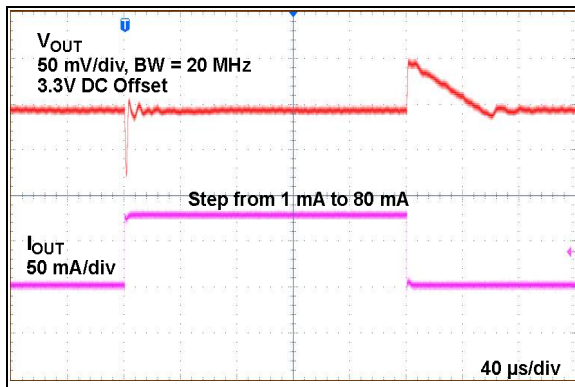


**FIGURE 2-17:** Power Supply Ripple Rejection Ratio vs. Frequency ( $V_R = 5.0\text{V}$ ).

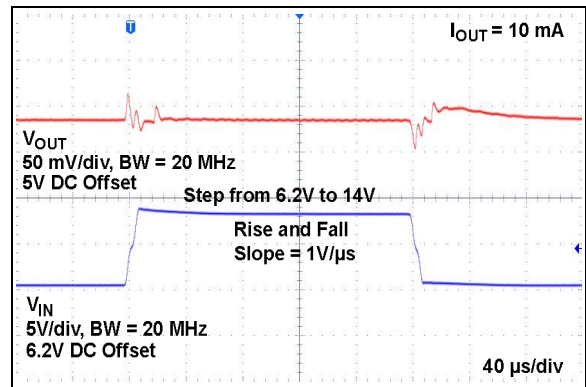


**FIGURE 2-15:** Noise vs. Frequency ( $V_R = 5.0\text{V}$ ).

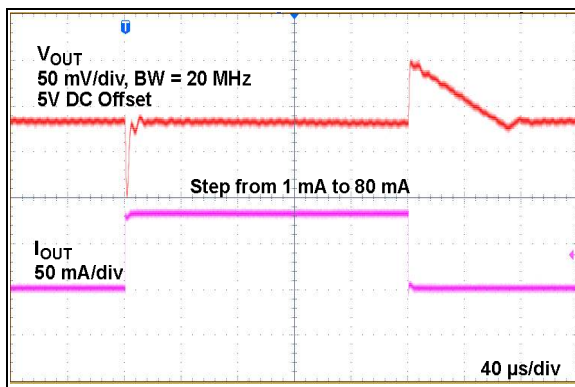
**Note:** Unless otherwise indicated,  $C_{IN} = C_{OUT} = 1 \mu\text{F}$  ceramic (X7R),  $I_{OUT} = 1 \text{ mA}$ ,  $T_A = +25^\circ\text{C}$ ,  $V_{IN} = V_R + 1.2\text{V}$ .



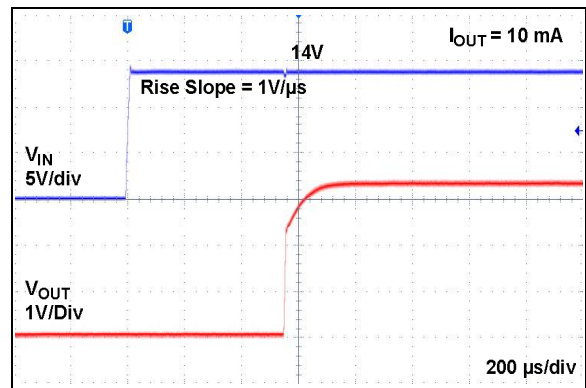
**FIGURE 2-18:** Load Step Response ( $V_R = 3.3\text{V}$ ).



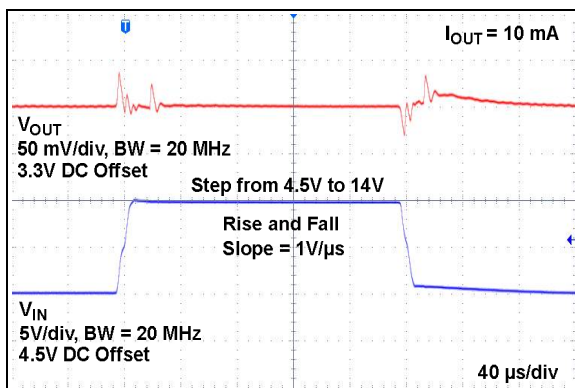
**FIGURE 2-21:** Line Step Response ( $V_R = 5.0\text{V}$ ).



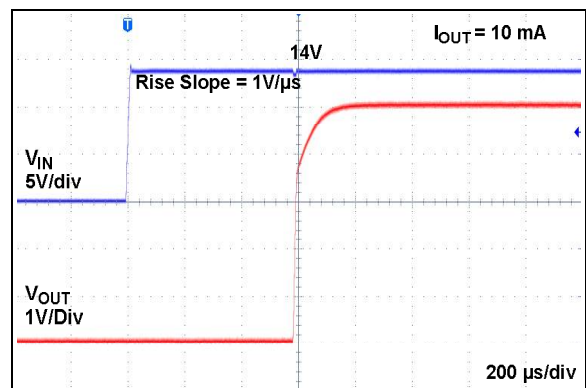
**FIGURE 2-19:** Load Step Response ( $V_R = 5.0\text{V}$ ).



**FIGURE 2-22:** Start-up ( $V_R = 3.3\text{V}$ ).

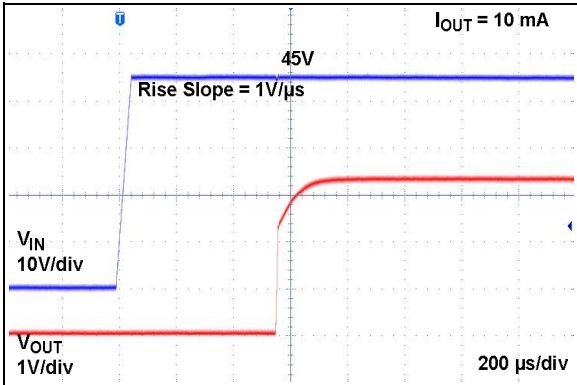


**FIGURE 2-20:** Line Step Response ( $V_R = 3.3\text{V}$ ).

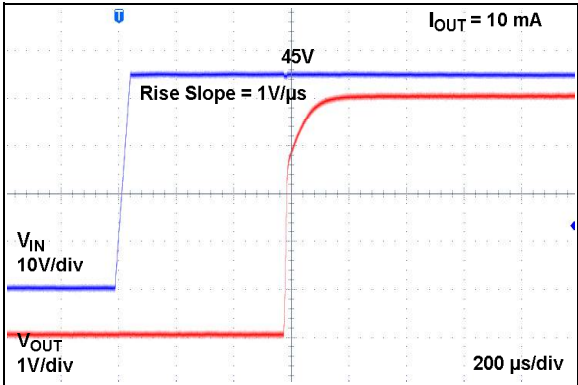


**FIGURE 2-23:** Start-up ( $V_R = 5.0\text{V}$ ).

**Note:** Unless otherwise indicated,  $C_{IN} = C_{OUT} = 1 \mu\text{F}$  ceramic (X7R),  $I_{OUT} = 1 \text{ mA}$ ,  $T_A = +25^\circ\text{C}$ ,  $V_{IN} = V_R + 1.2\text{V}$ .



**FIGURE 2-24:** Start-up ( $V_R = 3.3\text{V}$ ).



**FIGURE 2-25:** Start-up ( $V_R = 5\text{V}$ ).

## 3.0 PIN DESCRIPTION

The descriptions of the pins are listed in [Table 3-1](#).

**TABLE 3-1: PIN FUNCTION TABLE**

SOT 23-3	SOT 223-3	Symbol	Description
1	2	GND	Ground
2	3	V <sub>OUT</sub>	Regulated Output Voltage V <sub>R</sub>
3	1	V <sub>IN</sub>	Input Voltage Supply
—	4	TAB	Exposed Thermal Pad, connected internally to GND

### 3.1 Ground Pin (GND)

For optimal noise and Power Supply Rejection Ratio (PSRR) performance, the GND pin of the LDO should be tied to an electrically quiet circuit ground. This will ensure the LDO power supply rejection ratio and noise device performance. The GND pin of the LDO conducts only ground current, therefore a wide trace is not required. For applications that have switching or noisy inputs, tie the GND pin to the return of the output capacitor. Ground planes help lower the inductance and as a result, reduce the effect of fast current transients.

### 3.2 Regulated Output Voltage Pin (V<sub>OUT</sub>)

The V<sub>OUT</sub> pin is the regulated output voltage V<sub>R</sub> of the LDO. A minimum output capacitance of 1 μF is required for the LDO to ensure the stability in all the typical applications. The MCP1799 is stable with ceramic capacitors. See [Section 4.2, Output Capacitance Requirements](#) for output capacitor selection guidance.

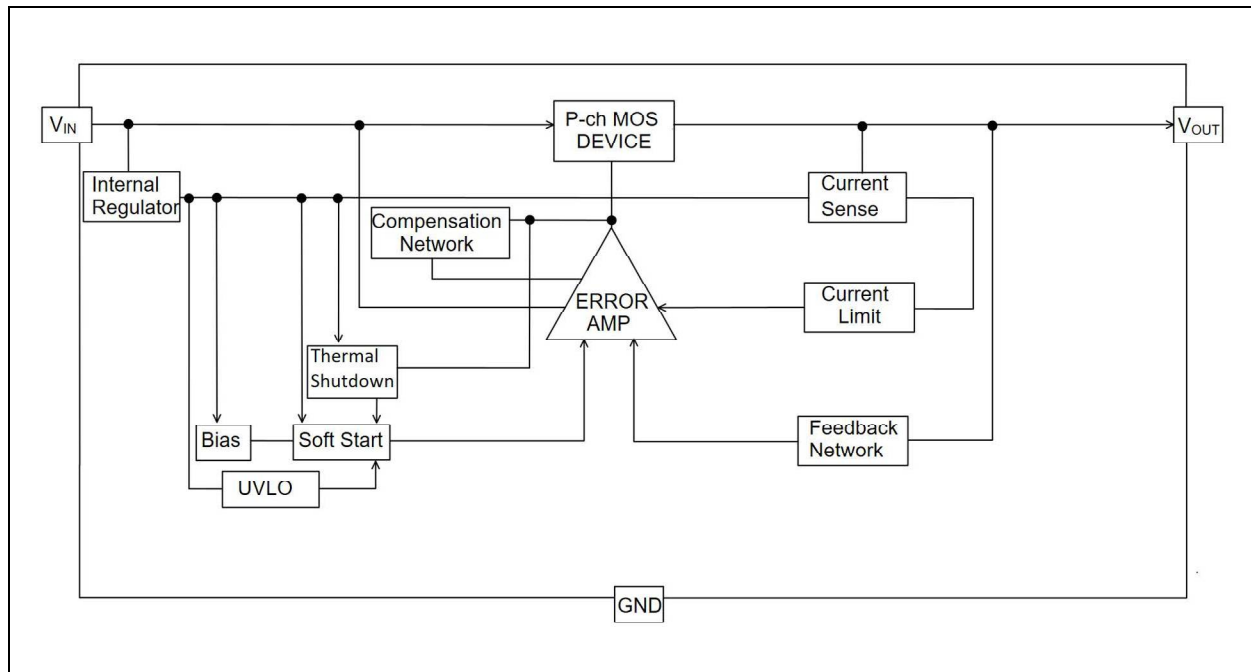
### 3.3 Input Voltage Supply Pin (V<sub>IN</sub>)

Connects the voltage source to V<sub>IN</sub>. If the input voltage source is located several inches away from the LDO, or the input source is a battery, it is recommended that an input capacitor be used. A typical input capacitance value of 1 μF to 10 μF should be sufficient for most applications. The type of capacitor used is ceramic. However, the low ESR characteristics of the ceramic capacitor will yield better noise and PSRR performance at high frequency.

## 4.0 DETAILED DESCRIPTION

### 4.1 Device Overview

The MCP1799 is an AEC-Q100 qualified LDO, capable of delivering 80 mA of current, over the entire operating temperature range. The part is stable with a minimum 1  $\mu$ F output ceramic capacitor, has current limit protection and extended working temperature range:  $-40^{\circ}$  to  $+150^{\circ}$ . The device also features a PSRR of 70 dB typical for 100 Hz frequency.



**FIGURE 4-1:** Simplified Functional Block Diagram.

### 4.2 Output Capacitance Requirements

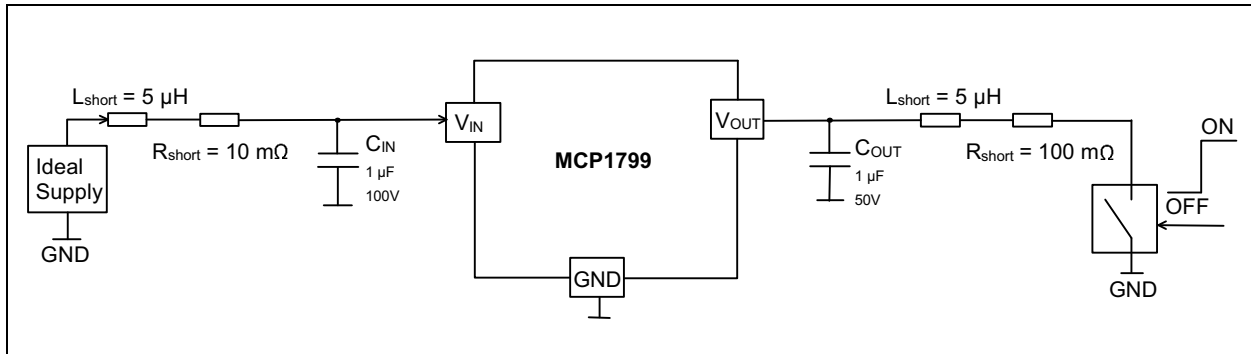
The MCP1799 requires a minimum output capacitance of 1  $\mu$ F for output voltage stability. The output capacitor should be located as close to the LDO output as it is practical. The device is designed to work with low ESR ceramic capacitors. Ceramic materials X8R/L or X7R have low temperature coefficients and are well within the acceptable ESR range required. A typical 1  $\mu$ F X7R 0805 capacitor has an ESR of 50 m $\Omega$ . It is recommended to use an appropriate voltage rating capacitor, and the derating of the capacitance as a function of voltage and temperature needs to be taken into account. For improved transitory behavior over the entire temperature range, a 2.2  $\mu$ F output capacitor is recommended. The ceramic capacitor type should be X7R or X8R/L because their dielectrics are rated for use with temperatures between  $-40^{\circ}$ C to  $+125^{\circ}$ C or  $-55^{\circ}$ C to  $+150^{\circ}$ C, respectively.

### 4.3 Input Capacitance Requirements

Low input-source impedance is necessary for the LDO output to operate properly. When operating from batteries, or in applications with long lead length (>10 inches) between the input source and the LDO, adding input capacitance is recommended. A minimum of 1  $\mu$ F to 10  $\mu$ F of capacitance is sufficient for most applications. Given the high input voltage capability of the MCP1799, of up to 45V DC, it is recommended to use an appropriate voltage rating capacitor, and the derating of the capacitance as a function of voltage and temperature needs to be taken into account. The ceramic capacitor type should be X7R or X8R/L because their dielectrics are rated for use with temperatures between  $-40^{\circ}$ C to  $+125^{\circ}$ C or  $-55^{\circ}$ C to  $+150^{\circ}$ C, respectively.

## 4.4 Circuit Protection

The MCP1799 features current limit protection during an output short circuit event that occurs in normal operation.



**FIGURE 4-2:** Short Circuit Test Set-Up.

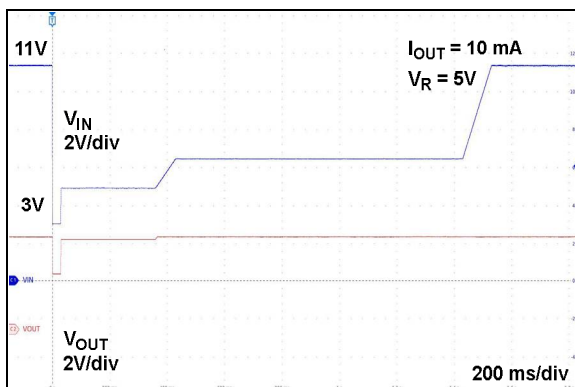
The MCP1799 was tested using the AEC-Q100 test set-up as shown in Figure 4-2. The testing conditions require the use of very high parasitic inductances on the input and output. For cases like this, it is required to prevent the output voltage going below ground with more than 1V.

Note that the  $V_{OUT}$  pin can withstand a maximum of  $-0.3V_{DC}$  (see **Absolute Maximum Ratings (†)**). This can be achieved by placing a Schottky diode with the cathode to  $V_{OUT}$  and anode to ground.

Thermal shutdown functionality is present on the device and adds to the protection features of the part. Thermal shutdown gets triggered at typical value of  $+180^{\circ}\text{C}$  and has a typical hysteresis of  $22^{\circ}$ .

## 4.5 Dropout Operation

For  $V_R = 5\text{V}$ , MCP1799 can be found operating in a dropout condition (the minimum input voltage is 4.5V), which can happen during a cold crank event, when the supply voltage can drop down to 3V. It is preferred to make sure that the part does not operate in dropout during DC operation so that the AC performance is maintained. See Figure 4-3.



**FIGURE 4-3:** Line Step from Dropout.

The device has a dropout voltage of approximately 300 mV at full load and room temperature, but because of the extended temperature range at  $+150^{\circ}\text{C}$ , due to increased leakage at hot, it reaches up to 1100 mV. For a 5V output, the minimum supply voltage required in order to have a regulated output, within specification, is 6.2V.

## 4.6 Input UVLO

On the rising edge of the  $V_{IN}$  input, the internal architecture adds 550  $\mu\text{s}$  delay before allowing the regulator output to turn on. After this 550  $\mu\text{s}$  delay, the regulator starts charging the load capacitor as the output rises from 0V to its regulated value. The charging current amplitude will be limited by the short circuit current value of the device.

The UVLO block helps prevent false start-ups, during the power-up sequence, until the input voltage reaches a value of 2.8V. The minimum input voltage required for normal operation is 4.5V.

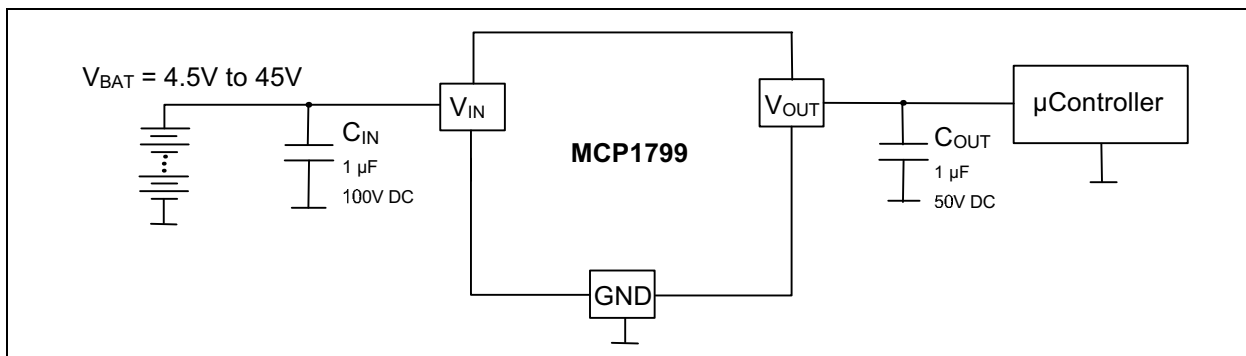
## 4.7 Package and Device Qualifications

The MCP1799 are AEC-Q100, grade 0 and PPAP capable. The Grade 0 qualification allows the MCP1799 to be used within an extended temperature range, from  $-40^{\circ}\text{C}$  to  $+150^{\circ}\text{C}$ .

## 5.0 APPLICATION INFORMATION

### 5.1 Typical Application

The MCP1799 is used for applications that require high input voltage and are prone to high transient voltages on the input.



**FIGURE 5-1:** Typical Application Circuit using a High Voltage Battery Pack.

### 5.2 Power Calculations

#### 5.2.1 POWER DISSIPATION

The internal power dissipation within the MCP1799 is a function of input voltage, output voltage, output current and quiescent current. Equation 5-1 can be used to calculate the internal power dissipation for the LDO.

#### EQUATION 5-1:

$$P_{LDO} = (V_{IN(MAX)} - V_{OUT(MIN)}) \times I_{OUT(MAX)}$$

Where:

$P_{LDO}$  = Internal power dissipation of the LDO pass device

$V_{IN(MAX)}$  = Maximum input voltage

$V_{OUT(MIN)}$  = LDO minimum output voltage

$I_{OUT(MAX)}$  = Maximum output current

In addition to the LDO pass element power dissipation, there is power dissipation within the MCP1799 as a result of quiescent or ground current. The power dissipation, as a result of the ground current, can be calculated by applying Equation 5-2:

#### EQUATION 5-2:

$$P_{I(GND)} = V_{IN(MAX)} \times I_{GND}$$

Where:

$P_{I(GND)}$  = Power dissipation due to the ground current of the LDO

$V_{IN(MAX)}$  = Maximum input voltage

$I_{GND}$  = Current flowing into the GND pin

The total power dissipated within the MCP1799 is the sum of the power dissipated in the LDO pass device and the  $P_{I(GND)}$  term. Because of the CMOS construction, the typical  $I_{GND}$  for the MCP1799 is typical 50  $\mu$ A at full load. Operating at a maximum  $V_{IN}$  of 45V results in a power dissipation of 2.25 mW. For most applications, this is small compared to the LDO pass device power dissipation and can be neglected.

The maximum continuous operating junction temperature specified for the MCP1799 is +150°C. To estimate the internal junction temperature of the MCP1799, the total internal power dissipation is multiplied by the thermal resistance from junction-to-ambient ( $R_{\theta JA}$ ) of the device. See Equation 5-3. For example, the thermal resistance from junction-to-ambient for the 3-Lead SOT-223 package is estimated at 70°C/W.

#### EQUATION 5-3:

$$T_{J(MAX)} = P_{LDO} \times \theta_{JA} + T_{A(MAX)}$$

Where:

$T_{J(MAX)}$  = Maximum continuous junction temperature

$P_{LDO}$  = Total power dissipation of the device

$\theta_{JA}$  = Thermal resistance from junction-to-ambient

$T_{A(MAX)}$  = Maximum ambient temperature



The maximum power dissipation capability for a package can be calculated given the junction-to-ambient thermal resistance and the maximum ambient temperature for the application. Equation 5-4 can be used to determine the package maximum internal power dissipation.

#### EQUATION 5-4:

$$P_{D(MAX)} = \frac{(T_{J(MAX)} - T_{A(MAX)})}{\theta_{JA}}$$

Where:

- $P_{D(MAX)}$  = Maximum power dissipation of the device
- $T_{J(MAX)}$  = Maximum continuous junction temperature
- $T_{A(MAX)}$  = Maximum ambient temperature
- $\theta_{JA}$  = Thermal resistance from junction-to-ambient

#### EQUATION 5-5:

$$T_{J(RISE)} = P_{D(MAX)} \times \theta_{JA}$$

Where:

- $T_{J(RISE)}$  = Rise in the device junction temperature over the ambient temperature
- $P_{D(MAX)}$  = Maximum power dissipation of the device
- $\theta_{JA}$  = Thermal resistance from junction-to-ambient

#### EQUATION 5-6:

$$T_J = T_{J(RISE)} + T_A$$

Where:

- $T_J$  = Junction temperature
- $T_{J(RISE)}$  = Rise in the device junction temperature over the ambient temperature
- $T_A$  = Ambient temperature

## 5.3 Typical Application Examples

Internal power dissipation, junction temperature rise, junction temperature and maximum power dissipation are calculated in the following example. The power dissipation as a result of ground current is small enough to be neglected.

Note that the formulas to calculate Example 5-1 are shown in Equation 5-5 and Equation 5-6.

### 5.3.1 POWER DISSIPATION EXAMPLE

#### EXAMPLE 5-1:

##### Package

Package Type = 3 Lead SOT223

##### Input Voltage

$V_{IN} = 14V \pm 5\%$

##### LDO Output Voltage and Current

$V_{OUT} = 5V$

$I_{OUT} = 50\text{ mA}$

##### Maximum Ambient Temperature

$T_{A(MAX)} = +60^\circ\text{C}$

##### Internal Power Dissipation

$P_{LDO(MAX)} = (V_{IN(MAX)} - V_{OUT(MIN)}) \times I_{OUT(MAX)}$

$P_{LDO} = (14.7 - 4.9) \times 50\text{ mA}$

$P_{LDO} = 0.49\text{ Watts}$

#### 5.3.1.1 Device Junction Temperature Rise

The internal junction temperature rise is a function of internal power dissipation and of the thermal resistance from junction-to-ambient for the application. The thermal resistance from junction-to-ambient ( $\theta_{JA}$ ) is derived from EIA/JEDEC standards for measuring thermal resistance. The EIA/JEDEC specification is JESD51. The standard describes the test method and board specifications for measuring the thermal resistance from junction-to-ambient. The actual thermal resistance for a particular application can vary depending on many factors such as copper area and thickness. Refer to Application Note AN792, "A Method to Determine How Much Power a SOT23 Can Dissipate in an Application" (DS00792), for more information regarding this subject.

#### EXAMPLE 5-2:

$T_{J(RISE)} = P_{LDO(Max)} \times \theta_{JA}$

$T_{J(RISE)} = 0.49\text{W} \times 70^\circ\text{C/W}$

$T_{J(RISE)} = 34.3^\circ\text{C}$

## 5.3.1.2 Junction Temperature Estimate

To estimate the internal junction temperature, the calculated temperature rise is added to the ambient or offset temperature. For this example, the worst-case junction temperature is estimated below:

### EXAMPLE 5-3:

$$\begin{aligned}T_J &= T_{J(\text{RISE})} + T_{A(\text{MAX})} \\T_J &= 34.3^\circ\text{C} + 60.0^\circ\text{C} \\T_J &= 94.3^\circ\text{C}\end{aligned}$$

## 5.3.1.3 Maximum Package Power Dissipation at +60°C Ambient Temperature

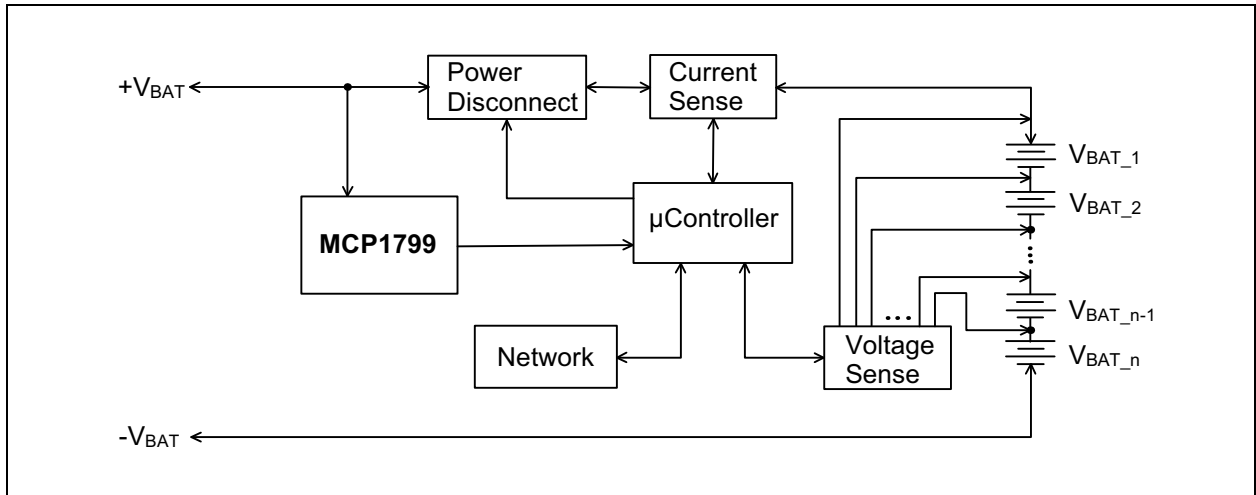
### EXAMPLE 5-4:

**3Lead SOT223 ( $\theta_{JA} = 70^\circ\text{C/W}$ ):**

$$\begin{aligned}P_{D(\text{MAX})} &= (150^\circ\text{C} - 60^\circ\text{C})/70^\circ\text{C/W} \\P_{D(\text{MAX})} &= 1.28\text{W}\end{aligned}$$

## 6.0 BATTERY PACK APPLICATION

The features of the MCP1799 make it a candidate for use in smart battery packs. The high input voltage range of up to 45V and the transient voltage capability makes it ideal for powering low-power microcontrollers used for monitoring battery health.

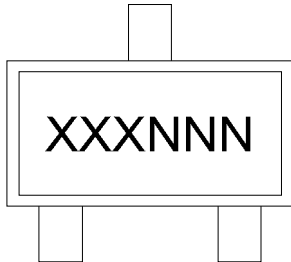


**FIGURE 6-1:** Smart Battery Pack Application Example.

## 7.0 PACKAGING INFORMATION

### 7.1 Package Marking Information

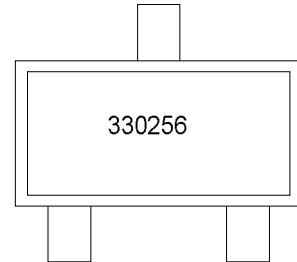
3-Lead SOT-23



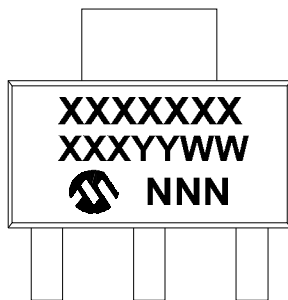
Part Number	Code
MCP1799T-3302H/TT(VAO)	330
MCP1799T-5002H/TT(VAO)	500

**Note:** The content of this table applies to 3-Lead SOT-23.

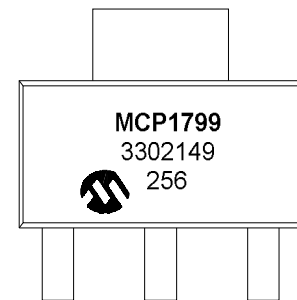
Example



3-Lead SOT-223



Example

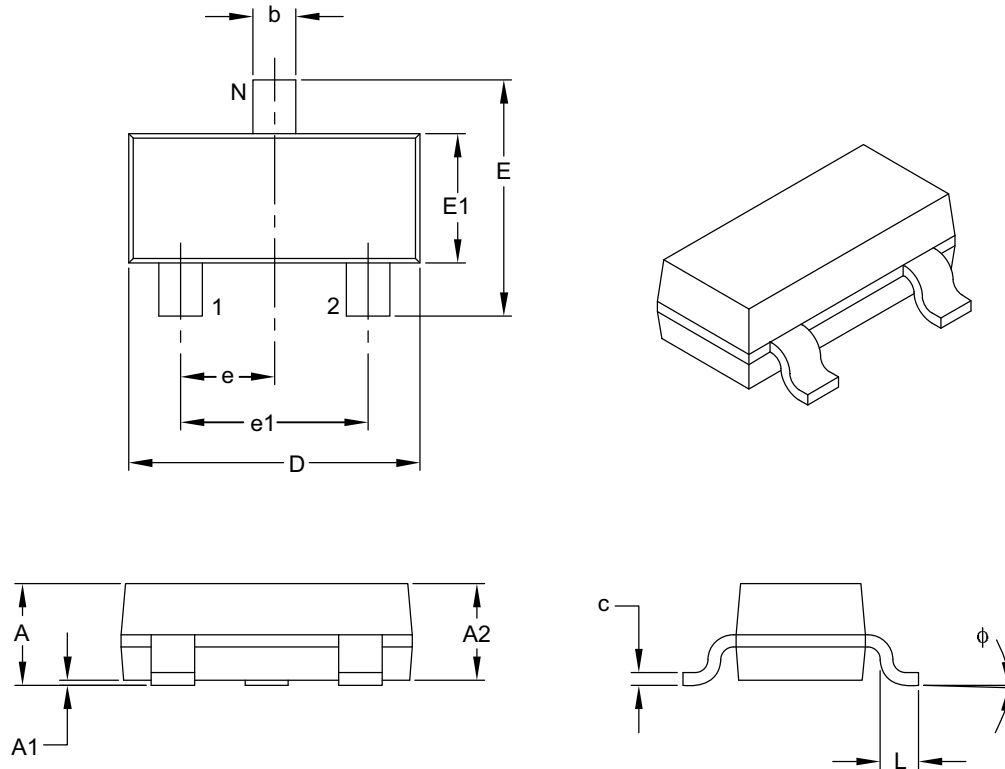


<b>Legend:</b>	XX...X	Customer-specific information
	Y	Year code (last digit of calendar year)
	YY	Year code (last 2 digits of calendar year)
	WWW	Week code (week of January 1 is week '01')
	NNN	Alphanumeric traceability code
	(e3)	Pb-free JEDEC® designator for Matte Tin (Sn)
	*	This package is Pb-free. The Pb-free JEDEC designator (e3) can be found on the outer packaging for this package.

**Note:** In the event the full Microchip part number cannot be marked on one line, it will be carried over to the next line, thus limiting the number of available characters for customer-specific information.

## 3-Lead Plastic Small Outline Transistor (TT) [SOT-23]

**Note:** For the most current package drawings, please see the Microchip Packaging Specification located at <http://www.microchip.com/packaging>



Dimension Limits	Units	MILLIMETERS		
		MIN	NOM	MAX
Number of Pins	N	3		
Lead Pitch	e	0.95 BSC		
Outside Lead Pitch	e1	1.90 BSC		
Overall Height	A	0.89	–	1.12
Molded Package Thickness	A2	0.79	0.95	1.02
Standoff	A1	0.01	–	0.10
Overall Width	E	2.10	–	2.64
Molded Package Width	E1	1.16	1.30	1.40
Overall Length	D	2.67	2.90	3.05
Foot Length	L	0.13	0.50	0.60
Foot Angle	φ	0°	–	10°
Lead Thickness	c	0.08	–	0.20
Lead Width	b	0.30	–	0.54

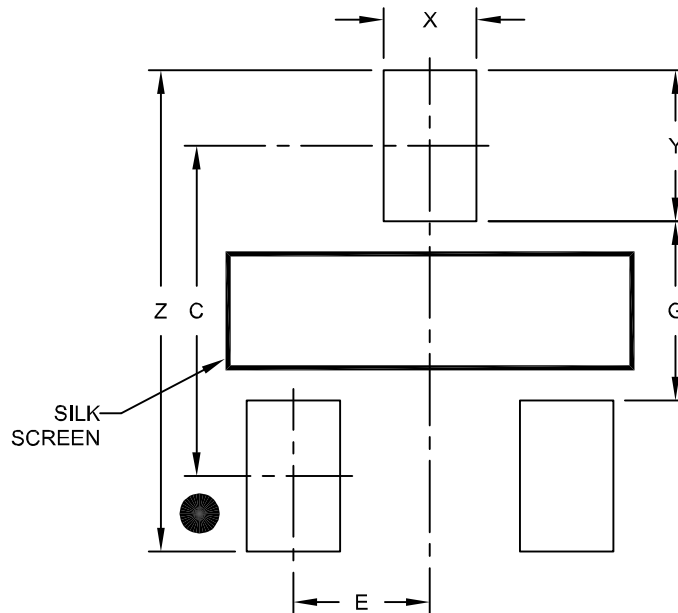
**Notes:**

- Dimensions D and E1 do not include mold flash or protrusions. Mold flash or protrusions shall not exceed 0.25 mm per side.
- Dimensioning and tolerancing per ASME Y14.5M.  
BSC: Basic Dimension. Theoretically exact value shown without tolerances.

Microchip Technology Drawing C04-104B

## 3-Lead Plastic Small Outline Transistor (TT) [SOT-23]

**Note:** For the most current package drawings, please see the Microchip Packaging Specification located at <http://www.microchip.com/packaging>



RECOMMENDED LAND PATTERN

Dimension Limits	Units	MILLIMETERS		
		MIN	NOM	MAX
Contact Pitch	E	0.95 BSC		
Contact Pad Spacing	C		2,30	
Contact Pad Width (X3)	X			0,65
Contact Pad Length (X3)	Y			1,05
Distance Between Pads	G	1,25		
Overall Width	Z			3,35

**Notes:**

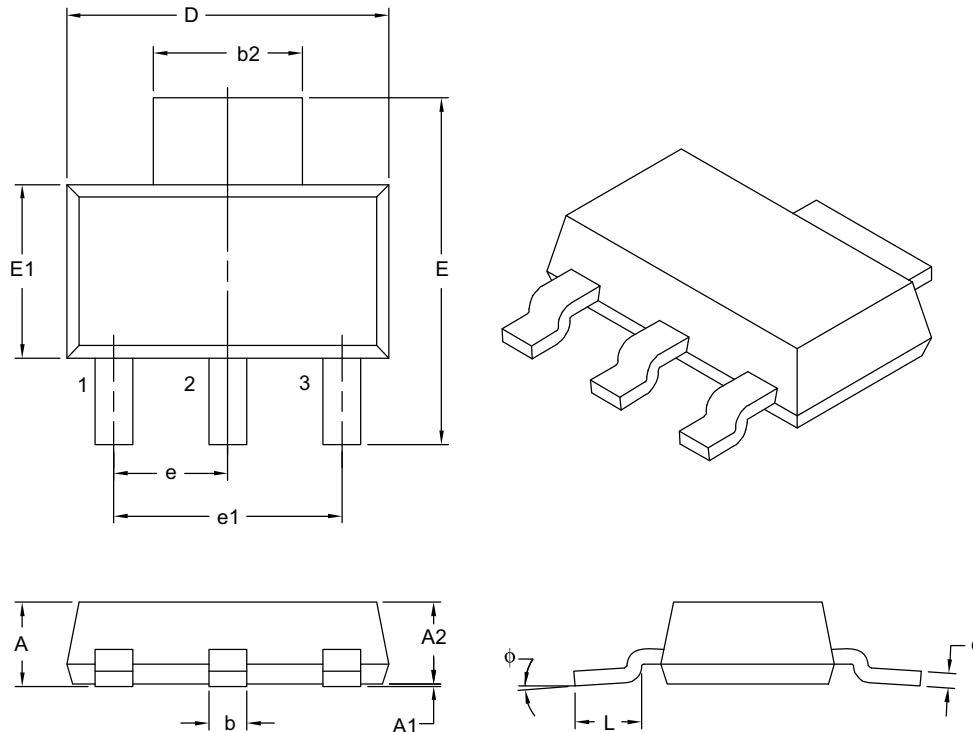
1. Dimensioning and tolerancing per ASME Y14.5M

BSC: Basic Dimension. Theoretically exact value shown without tolerances.

Microchip Technology Drawing No. C04-2104A

## 3-Lead Plastic Small Outline Transistor (DB) [SOT-223]

**Note:** For the most current package drawings, please see the Microchip Packaging Specification located at <http://www.microchip.com/packaging>



Dimension Limits	Units	MILLIMETERS		
		MIN	NOM	MAX
Number of Leads	N	3		
Lead Pitch	e	2.30 BSC		
Outside Lead Pitch	e1	4.60 BSC		
Overall Height	A	–	–	1.80
Standoff	A1	0.02	–	0.10
Molded Package Height	A2	1.50	1.60	1.70
Overall Width	E	6.70	7.00	7.30
Molded Package Width	E1	3.30	3.50	3.70
Overall Length	D	6.30	6.50	6.70
Lead Thickness	c	0.23	0.30	0.35
Lead Width	b	0.60	0.76	0.84
Tab Lead Width	b2	2.90	3.00	3.10
Foot Length	L	0.75	–	–
Lead Angle	$\phi$	0°	–	10°

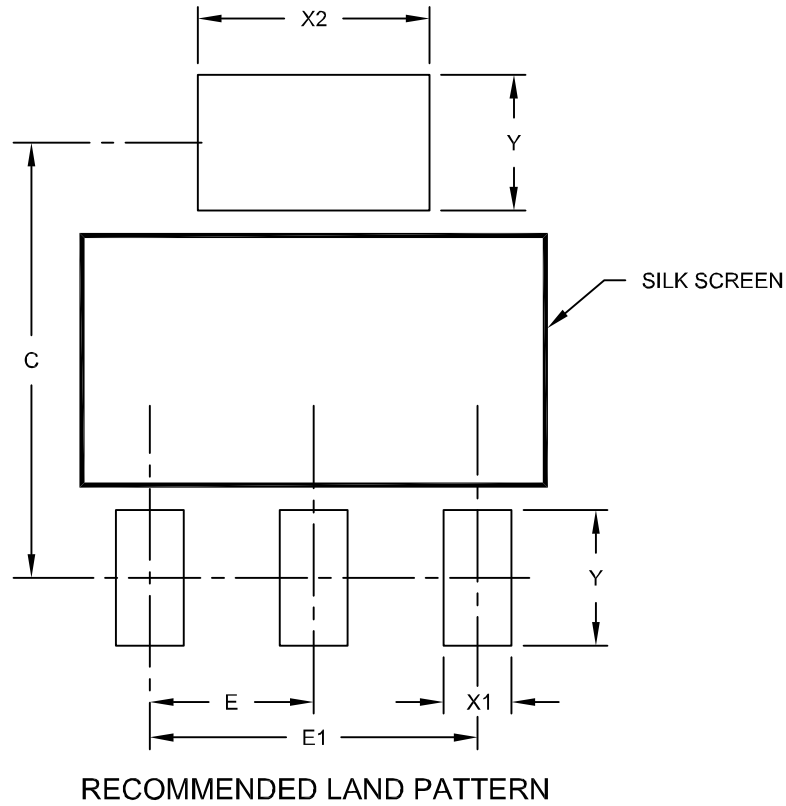
**Notes:**

- Dimensions D and E1 do not include mold flash or protrusions. Mold flash or protrusions shall not exceed 0.127 mm per side.
- Dimensioning and tolerancing per ASME Y14.5M.  
BSC: Basic Dimension. Theoretically exact value shown without tolerances.

Microchip Technology Drawing C04-032B

## 3-Lead Plastic Small Outline Transistor (DB) [SOT-223]

**Note:** For the most current package drawings, please see the Microchip Packaging Specification located at <http://www.microchip.com/packaging>



Dimension Limits	Units	MILLIMETERS		
		MIN	NOM	MAX
Contact Pitch	E	2.30 BSC		
Overall Pitch	E1	4.60 BSC		
Contact Pad Spacing	C		6.10	
Contact Pad Width	X1			0.95
Contact Pad Width	X2			3.25
Contact Pad Length	Y			1.90

**Notes:**

1. Dimensioning and tolerancing per ASME Y14.5M

BSC: Basic Dimension. Theoretically exact value shown without tolerances.

Microchip Technology Drawing No. C04-2032A



## PRODUCT IDENTIFICATION SYSTEM

To order or obtain information, e.g., on pricing or delivery, refer to the factory or the listed sales office.

PART NO.	(X) <sup>(1)</sup>	-XX	X	X	X/	XX	XXX	Examples:
Device	Tape and Reel Option	Output Voltage	Featured Code	Tolerance	Temp.	Package	Qualification	
Device:		MCP1799:						
Tape and Reel Option:	<Blank> T							a) MCP1799T-3302H/TT: Tape and Reel, 3.3V output voltage, Automotive temperature, 3-LD SOT-23 package
								b) MCP1799T-5002H/TT: Tape and Reel, 5.0V output voltage, Automotive temperature, 3-LD SOT-23 package
Standard Output Voltages:	33 50							c) MCP1799-3302H/DB: Tube, 3.3V output voltage, Automotive temperature, 3-LD SOT-223 package
								d) MCP1799-5002H/DB: Tube, 5.0V output voltage, Automotive temperature, 3-LD SOT-223 package
Temperature:	H							e) MCP1799T-3302H/DB: Tape and Reel, 3.3V output voltage, Automotive temperature, 3-LD SOT-223 package
								f) MCP1799T-5002H/DB: Tape and Reel, 5.0V output voltage, Automotive temperature, 3-LD SOT-223 package
Feature Code:	0							g) MCP1799T-3302H/DBVAO: Tape and Reel, 3.3V output voltage, 3-LD SOT-223 package, Automotive Qualified
								h) MCP1799T-5002H/DBVAO: Tape and Reel, 5.0V output voltage, 3-LD SOT-223 package, Automotive Qualified
Tolerance:	2							i) MCP1799T-3302H/TTVAO: Tape and Reel, 3.3V output voltage, 3-LD SOT-23 package, Automotive Qualified
								j) MCP1799T-5002H/TTVAO: Tape and Reel, 5.0V output voltage, 3-LD SOT-23 package, Automotive Qualified
Package Type:	TT DB							
Qualification:	<Blank> VAO							

**Note 1:** Tape and Reel identifier only appears in the catalog part number description. This identifier is used for ordering purposes and is not printed on the device package. Check with your Microchip Sales Office for package availability with the Tape and Reel option.

NOTES:

## APPENDIX A: REVISION HISTORY

### Revision A (September 2019)

- Initial release of this document.

### Revision B (December 2021)

- Updated [Product Identification System](#) to include automotive qualification information and examples.
- Updated [Section 7.0, Packaging Information](#) layout and content.

---

---

**Note the following details of the code protection feature on Microchip products:**

- Microchip products meet the specifications contained in their particular Microchip Data Sheet.
- Microchip believes that its family of products is secure when used in the intended manner, within operating specifications, and under normal conditions.
- Microchip values and aggressively protects its intellectual property rights. Attempts to breach the code protection features of Microchip product is strictly prohibited and may violate the Digital Millennium Copyright Act.
- Neither Microchip nor any other semiconductor manufacturer can guarantee the security of its code. Code protection does not mean that we are guaranteeing the product is “unbreakable”. Code protection is constantly evolving. Microchip is committed to continuously improving the code protection features of our products.

---

This publication and the information herein may be used only with Microchip products, including to design, test, and integrate Microchip products with your application. Use of this information in any other manner violates these terms. Information regarding device applications is provided only for your convenience and may be superseded by updates. It is your responsibility to ensure that your application meets with your specifications. Contact your local Microchip sales office for additional support or, obtain additional support at <https://www.microchip.com/en-us/support/design-help/client-support-services>.

THIS INFORMATION IS PROVIDED BY MICROCHIP "AS IS". MICROCHIP MAKES NO REPRESENTATIONS OR WARRANTIES OF ANY KIND WHETHER EXPRESS OR IMPLIED, WRITTEN OR ORAL, STATUTORY OR OTHERWISE, RELATED TO THE INFORMATION INCLUDING BUT NOT LIMITED TO ANY IMPLIED WARRANTIES OF NON-INFRINGEMENT, MERCHANTABILITY, AND FITNESS FOR A PARTICULAR PURPOSE, OR WARRANTIES RELATED TO ITS CONDITION, QUALITY, OR PERFORMANCE.

IN NO EVENT WILL MICROCHIP BE LIABLE FOR ANY INDIRECT, SPECIAL, PUNITIVE, INCIDENTAL, OR CONSEQUENTIAL LOSS, DAMAGE, COST, OR EXPENSE OF ANY KIND WHATSOEVER RELATED TO THE INFORMATION OR ITS USE, HOWEVER CAUSED, EVEN IF MICROCHIP HAS BEEN ADVISED OF THE POSSIBILITY OR THE DAMAGES ARE FORESEEABLE. TO THE FULLEST EXTENT ALLOWED BY LAW, MICROCHIP'S TOTAL LIABILITY ON ALL CLAIMS IN ANY WAY RELATED TO THE INFORMATION OR ITS USE WILL NOT EXCEED THE AMOUNT OF FEES, IF ANY, THAT YOU HAVE PAID DIRECTLY TO MICROCHIP FOR THE INFORMATION.

Use of Microchip devices in life support and/or safety applications is entirely at the buyer's risk, and the buyer agrees to defend, indemnify and hold harmless Microchip from any and all damages, claims, suits, or expenses resulting from such use. No licenses are conveyed, implicitly or otherwise, under any Microchip intellectual property rights unless otherwise stated.

For information regarding Microchip's Quality Management Systems, please visit [www.microchip.com/quality](http://www.microchip.com/quality).

**Trademarks**

The Microchip name and logo, the Microchip logo, Adaptec, AnyRate, AVR, AVR logo, AVR Freaks, BesTime, BitCloud, CryptoMemory, CryptoRF, dsPIC, flexPWR, HELDO, IGLOO, JukeBlox, KeeLoq, Kleer, LANCheck, LinkMD, maXStylus, maXTouch, MediaLB, megaAVR, Microsemi, Microsemi logo, MOST, MOST logo, MPLAB, OptoLyzer, PIC, picoPower, PICSTART, PIC32 logo, PolarFire, Prochip Designer, QTouch, SAM-BA, SenGenuity, SpyNIC, SST, SST Logo, SuperFlash, Symmetricom, SyncServer, Tachyon, TimeSource, tinyAVR, UNI/O, Vectron, and XMEGA are registered trademarks of Microchip Technology Incorporated in the U.S.A. and other countries.

AgileSwitch, APT, ClockWorks, The Embedded Control Solutions Company, EtherSynch, Flashtec, Hyper Speed Control, HyperLight Load, IntelliMOS, Libero, motorBench, mTouch, Powermite 3, Precision Edge, ProASIC, ProASIC Plus, ProASIC Plus logo, QuietWire, SmartFusion, SyncWorld, Temux, TimeCesium, TimeHub, TimePictra, TimeProvider, TrueTime, WinPath, and ZL are registered trademarks of Microchip Technology Incorporated in the U.S.A.

Adjacent Key Suppression, AKS, Analog-for-the-Digital Age, Any Capacitor, AnyIn, AnyOut, Augmented Switching, BlueSky, BodyCom, CodeGuard, CryptoAuthentication, CryptoAutomotive, CryptoCompanion, CryptoController, dsPICDEM, dsPICDEM.net, Dynamic Average Matching, DAM, ECAN, Espresso T1S, EtherGREEN, GridTime, IdealBridge, In-Circuit Serial Programming, ICSP, INICnet, Intelligent Paralleling, Inter-Chip Connectivity, JitterBlocker, Knob-on-Display, maxCrypto, maxView, memBrain, Mindi, MiWi, MPASM, MPF, MPLAB Certified logo, MPLIB, MPLINK, MultiTRAK, NetDetach, NVM Express, NVMe, Omniscient Code Generation, PICDEM, PICDEM.net, PICKit, PICtail, PowerSmart, PureSilicon, QMatrix, REAL ICE, Ripple Blocker, RTAX, RTG4, SAM-ICE, Serial Quad I/O, simpleMAP, SimpliPHY, SmartBuffer, SmartHLS, SMART-I.S., storClad, SQI, SuperSwitcher, SuperSwitcher II, Switchtec, SynchroPHY, Total Endurance, TSHARC, USBCheck, VariSense, VectorBlox, VeriPHY, ViewSpan, WiperLock, XpressConnect, and ZENA are trademarks of Microchip Technology Incorporated in the U.S.A. and other countries.

SQTP is a service mark of Microchip Technology Incorporated in the U.S.A.

The Adaptec logo, Frequency on Demand, Silicon Storage Technology, Symmcom, and Trusted Time are registered trademarks of Microchip Technology Inc. in other countries.

GestIC is a registered trademark of Microchip Technology Germany II GmbH & Co. KG, a subsidiary of Microchip Technology Inc., in other countries.

All other trademarks mentioned herein are property of their respective companies.

© 2019-2021, Microchip Technology Incorporated and its subsidiaries.

All Rights Reserved.

ISBN: 978-1-5224-9464-5



# MICROCHIP

## Worldwide Sales and Service

### AMERICAS

**Corporate Office**  
2355 West Chandler Blvd.  
Chandler, AZ 85224-6199  
Tel: 480-792-7200  
Fax: 480-792-7277  
Technical Support:  
[http://www.microchip.com/  
support](http://www.microchip.com/support)  
Web Address:  
[www.microchip.com](http://www.microchip.com)

**Atlanta**  
Duluth, GA  
Tel: 678-957-9614  
Fax: 678-957-1455

**Austin, TX**  
Tel: 512-257-3370

**Boston**  
Westborough, MA  
Tel: 774-760-0087  
Fax: 774-760-0088

**Chicago**  
Itasca, IL  
Tel: 630-285-0071  
Fax: 630-285-0075

**Dallas**  
Addison, TX  
Tel: 972-818-7423  
Fax: 972-818-2924

**Detroit**  
Novi, MI  
Tel: 248-848-4000

**Houston, TX**  
Tel: 281-894-5983

**Indianapolis**  
Noblesville, IN  
Tel: 317-773-8323  
Fax: 317-773-5453  
Tel: 317-536-2380

**Los Angeles**  
Mission Viejo, CA  
Tel: 949-462-9523  
Fax: 949-462-9608  
Tel: 951-273-7800

**Raleigh, NC**  
Tel: 919-844-7510

**New York, NY**  
Tel: 631-435-6000

**San Jose, CA**  
Tel: 408-735-9110  
Tel: 408-436-4270

**Canada - Toronto**  
Tel: 905-695-1980  
Fax: 905-695-2078

### ASIA/PACIFIC

**Australia - Sydney**  
Tel: 61-2-9868-6733

**China - Beijing**  
Tel: 86-10-8569-7000

**China - Chengdu**  
Tel: 86-28-8665-5511

**China - Chongqing**  
Tel: 86-23-8980-9588

**China - Dongguan**  
Tel: 86-769-8702-9880

**China - Guangzhou**  
Tel: 86-20-8755-8029

**China - Hangzhou**  
Tel: 86-571-8792-8115

**China - Hong Kong SAR**  
Tel: 852-2943-5100

**China - Nanjing**  
Tel: 86-25-8473-2460

**China - Qingdao**  
Tel: 86-532-8502-7355

**China - Shanghai**  
Tel: 86-21-3326-8000

**China - Shenyang**  
Tel: 86-24-2334-2829

**China - Shenzhen**  
Tel: 86-755-8864-2200

**China - Suzhou**  
Tel: 86-186-6233-1526

**China - Wuhan**  
Tel: 86-27-5980-5300

**China - Xian**  
Tel: 86-29-8833-7252

**China - Xiamen**  
Tel: 86-592-2388138

**China - Zhuhai**  
Tel: 86-756-3210040

### ASIA/PACIFIC

**India - Bangalore**  
Tel: 91-80-3090-4444

**India - New Delhi**  
Tel: 91-11-4160-8631

**India - Pune**  
Tel: 91-20-4121-0141

**Japan - Osaka**  
Tel: 81-6-6152-7160

**Japan - Tokyo**  
Tel: 81-3-6880-3770

**Korea - Daegu**  
Tel: 82-53-744-4301

**Korea - Seoul**  
Tel: 82-2-554-7200

**Malaysia - Kuala Lumpur**  
Tel: 60-3-7651-7906

**Malaysia - Penang**  
Tel: 60-4-227-8870

**Philippines - Manila**  
Tel: 63-2-634-9065

**Singapore**  
Tel: 65-6334-8870

**Taiwan - Hsin Chu**  
Tel: 886-3-577-8366

**Taiwan - Kaohsiung**  
Tel: 886-7-213-7830

**Taiwan - Taipei**  
Tel: 886-2-2508-8600

**Thailand - Bangkok**  
Tel: 66-2-694-1351

**Vietnam - Ho Chi Minh**  
Tel: 84-28-5448-2100

### EUROPE

**Austria - Wels**  
Tel: 43-7242-2244-39  
Fax: 43-7242-2244-393

**Denmark - Copenhagen**  
Tel: 45-4485-5910  
Fax: 45-4485-2829

**Finland - Espoo**  
Tel: 358-9-4520-820

**France - Paris**  
Tel: 33-1-69-53-63-20  
Fax: 33-1-69-30-90-79

**Germany - Garching**  
Tel: 49-8931-9700

**Germany - Haan**  
Tel: 49-2129-3766400

**Germany - Heilbronn**  
Tel: 49-7131-72400

**Germany - Karlsruhe**  
Tel: 49-721-625370

**Germany - Munich**  
Tel: 49-89-627-144-0  
Fax: 49-89-627-144-44

**Germany - Rosenheim**  
Tel: 49-8031-354-560

**Israel - Ra'anana**  
Tel: 972-9-744-7705

**Italy - Milan**  
Tel: 39-0331-742611  
Fax: 39-0331-466781

**Italy - Padova**  
Tel: 39-049-7625286

**Netherlands - Drunen**  
Tel: 31-416-690399  
Fax: 31-416-690340

**Norway - Trondheim**  
Tel: 47-7288-4388

**Poland - Warsaw**  
Tel: 48-22-3325737

**Romania - Bucharest**  
Tel: 40-21-407-87-50

**Spain - Madrid**  
Tel: 34-91-708-08-90  
Fax: 34-91-708-08-91

**Sweden - Gothenberg**  
Tel: 46-31-704-60-40

**Sweden - Stockholm**  
Tel: 46-8-5090-4654

**UK - Wokingham**  
Tel: 44-118-921-5800  
Fax: 44-118-921-5820