



Product Change Notification / SYST-31HPWF472

Date:

01-Sep-2021

Product Category:

16-Bit - Microcontrollers and Digital Signal Controllers

PCN Type:

Document Change

Notification Subject:

ERRATA - dsPIC33CH128MP508 Family Silicon Errata and Datasheet Clarification

Affected CPNs:

[SYST-31HPWF472_Affected_CPN_09012021.pdf](#)

[SYST-31HPWF472_Affected_CPN_09012021.csv](#)

Notification Text:

SYST-31HPWF472

Microchip has released a new Product Documents for the dsPIC33CH128MP508 Family Silicon Errata and Datasheet Clarification of devices. If you are using one of these devices please read the document located at [dsPIC33CH128MP508 Family Silicon Errata and Datasheet Clarification](#).

Notification Status: Final**Description of Change:**

1. Updates silicon issue 36 (Secondary CPU).
2. Adds silicon issues 38 (ADC) and 39 (POR).

Impacts to Data Sheet: See above details

Reason for Change: To Improve Productivity

Change Implementation Status: Complete

Date Document Changes Effective: 1 September 2021

NOTE: Please be advised that this is a change to the document only the product has not been changed.

Markings to Distinguish Revised from Unrevised Devices: N/A

Attachments:

[dsPIC33CH128MP508 Family Silicon Errata and Datasheet Clarification](#)

Please contact your local [Microchip sales office](#) with questions or concerns regarding this notification.

Terms and Conditions:

If you wish to receive Microchip PCNs via email please register for our PCN email service at our [PCN home page](#) select register then fill in the required fields. You will find instructions about registering for Microchips PCN email service in the [PCN FAQ](#) section.

If you wish to change your PCN profile, including opt out, please go to the [PCN home page](#) select login and sign into your myMicrochip account. Select a profile option from the left navigation bar and make the applicable selections.

Affected Catalog Part Numbers (CPN)

DSPIC33CH64MP502-E/2N
DSPIC33CH128MP502-E/2N
DSPIC33CH64MP202-E/2NC01
DSPIC33CH64MP202-E/2N
DSPIC33CH128MP202-E/2N
DSPIC33CH64MP202-E/2NVAO
DSPIC33CH64MP502-E/SS
DSPIC33CH128MP502-E/SS
DSPIC33CH64MP202-E/SS
DSPIC33CH128MP202-E/SS
DSPIC33CH64MP505-E/M4
DSPIC33CH128MP505-E/M4
DSPIC33CH64MP205-E/M4
DSPIC33CH128MP205-E/M4
DSPIC33CH64MP506-E/MR
DSPIC33CH128MP506-E/MR
DSPIC33CH64MP206-E/MR
DSPIC33CH128MP206-E/MR
DSPIC33CH128MP506-E/MRVAO
DSPIC33CH64MP503-E/M5
DSPIC33CH128MP503-E/M5
DSPIC33CH128MP503-E/M5C01
DSPIC33CH64MP203-E/M5
DSPIC33CH128MP203-E/M5
DSPIC33CH64MP506-E/PT
DSPIC33CH128MP506-E/PT
DSPIC33CH64MP206-E/PT
DSPIC33CH128MP206-E/PT
DSPIC33CH64MP508-E/PT
DSPIC33CH128MP508-E/PT
DSPIC33CH64MP208-E/PT
DSPIC33CH128MP208-E/PT
DSPIC33CH128MP508-E/PTVAO
DSPIC33CH64MP505-E/PT
DSPIC33CH128MP505-E/PT
DSPIC33CH64MP205-E/PT
DSPIC33CH128MP205-E/PT
DSPIC33CH128MP505-E/PTVAO
DSPIC33CH64MP502-I/2N
DSPIC33CH128MP502-I/2N
DSPIC33CH64MP202-I/2N
DSPIC33CH128MP202-I/2N
DSPIC33CH64MP502-I/SS
DSPIC33CH128MP502-I/SS
DSPIC33CH64MP202-I/SS
DSPIC33CH128MP202-I/SS

DSPIC33CH64MP505-I/M4
DSPIC33CH128MP505-I/M4
DSPIC33CH64MP205-I/M4
DSPIC33CH128MP205-I/M4
DSPIC33CH64MP506-I/MR
DSPIC33CH128MP506-I/MR
DSPIC33CH64MP206-I/MR
DSPIC33CH128MP206-I/MR
DSPIC33CH64MP503-I/M5
DSPIC33CH128MP503-I/M5
DSPIC33CH64MP203-I/M5
DSPIC33CH128MP203-I/M5
DSPIC33CH64MP506-I/PT
DSPIC33CH128MP506-I/PT
DSPIC33CH128MP206-I/PTC01
DSPIC33CH64MP206-I/PT
DSPIC33CH128MP206-I/PT
DSPIC33CH64MP508-I/PT
DSPIC33CH128MP508-I/PT
DSPIC33CH64MP208-I/PT
DSPIC33CH128MP208-I/PT
DSPIC33CH64MP505-I/PT
DSPIC33CH128MP505-I/PT
DSPIC33CH64MP205-I/PT
DSPIC33CH128MP205-I/PT
DSPIC33CH64MP202T-H/2NVAO
DSPIC33CH64MP502-H/2N
DSPIC33CH128MP502-H/2N
DSPIC33CH64MP202-H/2N
DSPIC33CH128MP202-H/2N
DSPIC33CH64MP202-H/2NVAO
DSPIC33CH64MP502-H/SS
DSPIC33CH128MP502-H/SS
DSPIC33CH64MP202-H/SS
DSPIC33CH128MP202-H/SS
DSPIC33CH64MP505-H/M4
DSPIC33CH128MP505-H/M4
DSPIC33CH64MP205-H/M4
DSPIC33CH128MP205-H/M4
DSPIC33CH64MP506-H/MR
DSPIC33CH128MP506-H/MR
DSPIC33CH64MP206-H/MR
DSPIC33CH128MP206-H/MR
DSPIC33CH64MP503-H/M5
DSPIC33CH128MP503-H/M5
DSPIC33CH64MP203-H/M5
DSPIC33CH128MP203-H/M5
DSPIC33CH64MP506-H/PT
DSPIC33CH128MP506-H/PT

DSPIC33CH64MP206-H/PT
DSPIC33CH128MP206-H/PT
DSPIC33CH64MP508-H/PT
DSPIC33CH128MP508-H/PT
DSPIC33CH64MP208-H/PT
DSPIC33CH128MP208-H/PT
DSPIC33CH64MP505-H/PT
DSPIC33CH128MP505-H/PT
DSPIC33CH64MP205-H/PT
DSPIC33CH128MP205-H/PT
DSPIC33CH64MP502T-I/2N
DSPIC33CH128MP502T-I/2N
DSPIC33CH64MP202T-I/2N
DSPIC33CH128MP202T-I/2N
DSPIC33CH64MP502T-I/SS
DSPIC33CH128MP502T-I/SS
DSPIC33CH64MP202T-I/SS
DSPIC33CH128MP202T-I/SS
DSPIC33CH64MP505T-I/M4
DSPIC33CH128MP505T-I/M4
DSPIC33CH64MP205T-I/M4
DSPIC33CH128MP205T-I/M4
DSPIC33CH64MP506T-I/MR
DSPIC33CH128MP506T-I/MR
DSPIC33CH64MP206T-I/MR
DSPIC33CH128MP206T-I/MR
DSPIC33CH64MP503T-I/M5
DSPIC33CH128MP503T-I/M5
DSPIC33CH64MP203T-I/M5
DSPIC33CH128MP203T-I/M5
DSPIC33CH64MP506T-I/PT
DSPIC33CH128MP506T-I/PT
DSPIC33CH128MP206T-I/PTC01
DSPIC33CH64MP206T-I/PT
DSPIC33CH128MP206T-I/PT
DSPIC33CH64MP508T-I/PT
DSPIC33CH128MP508T-I/PT
DSPIC33CH64MP208T-I/PT
DSPIC33CH128MP208T-I/PT
DSPIC33CH64MP505T-I/PT
DSPIC33CH128MP505T-I/PT
DSPIC33CH64MP205T-I/PT
DSPIC33CH128MP205T-I/PT
DSPIC33CH128MP505T-I/PTVAO
DSPIC33CH64MP202T-E/2NVAO
DSPIC33CH128MP506T-E/MRV03
DSPIC33CH128MP506T-E/MRVAO
DSPIC33CH128MP508T-E/PTVAO
DSPIC33CH128MP505T-E/PTV02

dsPIC33CH128MP508 Family Silicon Errata and Data Sheet Clarification

The dsPIC33CH128MP508 family devices that you have received conform functionally to the current Device Data Sheet (DS70005319D), except for the anomalies described in this document.

The silicon issues discussed in the following pages are for silicon revisions with the Device and Revision IDs listed in [Table 1](#). The silicon issues are summarized in [Table 2](#).

The errata described in this document will be addressed in future revisions of the dsPIC33CH128MP508 silicon.

Note: This document summarizes all silicon errata issues from all revisions of silicon, previous as well as current. Only the issues indicated in the last column of [Table 2](#) apply to the current silicon revision (**B0**).

Data Sheet clarifications and corrections start on [page 14](#), following the discussion of silicon issues.

The silicon revision level can be identified using the current version of MPLAB® IDE and Microchip's programmers, debuggers and emulation tools, which are available at the Microchip corporate website (www.microchip.com).

For example, to identify the silicon revision level using MPLAB IDE in conjunction with a hardware debugger:

1. Using the appropriate interface, connect the device to the hardware debugger.
2. Open an MPLAB IDE project.
3. Configure the MPLAB IDE project for the appropriate device and hardware debugger.
4. Based on the version of MPLAB IDE you are using, do one of the following:
 - a) For MPLAB IDE 8, select *Programmer > Reconnect*.
 - b) For MPLAB X IDE, select *Window > Dashboard* and click the **Refresh Debug Tool Status** icon ().
5. Depending on the development tool used, the part number *and* Device Revision ID value appear in the **Output** window.

Note: If you are unable to extract the silicon revision level, please contact your local Microchip sales office for assistance.

The DEVREV values for the various dsPIC33CH128MP508 silicon revisions are shown in [Table 1](#).

TABLE 1: SILICON DEVREV VALUES

Part Number	Device ID ⁽¹⁾	Revision ID for Silicon Revision	
		A2	B0
Main (With CAN FD)			
dsPIC33CH64MP502	0x8740	0x0002	0x0003
dsPIC33CH128MP502	0x8750		
dsPIC33CH64MP503	0x8741		
dsPIC33CH128MP503	0x8751		
dsPIC33CH64MP505	0x8742		
dsPIC33CH128MP505	0x8752		
dsPIC33CH64MP506	0x8743		
dsPIC33CH128MP506	0x8753		
dsPIC33CH64MP508	0x8744		
dsPIC33CH128MP508	0x8754		

Note 1: The Device IDs (DEVID and DEVREV) are located at the last two implemented addresses of configuration memory space. They are shown in hexadecimal in the format "DEVID DEVREV".

dsPIC33CH128MP508

TABLE 1: SILICON DEVREV VALUES (CONTINUED)

Part Number	Device ID ⁽¹⁾	Revision ID for Silicon Revision	
		A2	B0
Secondary (With CAN FD)			
dsPIC33CH64MP502S1	0x87C0	0x0002	0x0003
dsPIC33CH128MP502S1	0x87D0		
dsPIC33CH64MP503S1	0x87C1		
dsPIC33CH128MP503S1	0x87D1		
dsPIC33CH64MP505S1	0x87C2		
dsPIC33CH128MP505S1	0x87D2		
dsPIC33CH64MP506S1	0x87C3		
dsPIC33CH128MP506S1	0x87D3		
dsPIC33CH64MP508S1	0x87C4		
dsPIC33CH128MP508S1	0x87D4		
Main (Without CAN FD)			
dsPIC33CH64MP202	0x8700	0x0002	0x0003
dsPIC33CH128MP202	0x8710		
dsPIC33CH64MP203	0x8701		
dsPIC33CH128MP203	0x8711		
dsPIC33CH64MP205	0x8702		
dsPIC33CH128MP205	0x8712		
dsPIC33CH64MP206	0x8703		
dsPIC33CH128MP206	0x8713		
dsPIC33CH64MP208	0x8704		
dsPIC33CH128MP208	0x8714		
Secondary (Without CAN FD)			
dsPIC33CH64MP202S1	0x8780	0x0002	0x0003
dsPIC33CH128MP202S1	0x8790		
dsPIC33CH64MP203S1	0x8781		
dsPIC33CH128MP203S1	0x8791		
dsPIC33CH64MP205S1	0x8782		
dsPIC33CH128MP205S1	0x8792		
dsPIC33CH64MP206S1	0x8783		
dsPIC33CH128MP206S1	0x8793		
dsPIC33CH64MP208S1	0x8784		
dsPIC33CH128MP208S1	0x8794		

Note 1: The Device IDs (DEVID and DEVREV) are located at the last two implemented addresses of configuration memory space. They are shown in hexadecimal in the format "DEVID DEVREV".

TABLE 2: SILICON ISSUE SUMMARY

Module	Feature	Item Number	Issue Summary	Affected Revisions	
				A2	B0
ECC	Status	1.	ECCSTATH/L registers cannot be read.	X	
ECC	Status	2.	SECSYNDx bits in the ECCSTATH register cannot be read.	X	
I ² C	Interrupt	3.	In Client mode, an incorrect interrupt is generated with DHEN = 1.	X	X
I ² C	Error	4.	Bus collision error cannot be cleared.	X	X
I ² C	Error	5.	False bus collision error generated.	X	X
I ² C	Idle	6.	Address cannot be received in Idle mode.	X	X
Oscillator	PLL	7.	FRCDIVN drives the PLL instead of the FRC.	X	X
Oscillator	HS, XT	8.	Removed		
PWM	Dead Time	9.	When feed-forward PCI is used for dead-time compensation (DTCMPSEL = 1), the PWMx outputs are overridden.	X	X
UART	OERR	10.	The OERR bit cannot be cleared by software.	X	X
UART	FERR	11.	The FERR bit will not get set if one Stop bit is received.	X	X
UART	OERR	12.	The 9th byte received will not be available to be read.	X	X
UART	TRMT	13.	The TRMT bit takes time to set on the last transmit completion.	X	X
UART	TRMT	14.	The TRMT bit is unreliable when there is back-to-back Break character transmission.	X	X
UART	Idle	15.	SLPEN = 1 will not keep the UART BRG clock active in Sleep mode.	X	X
UART	RIDLE	16.	The RIDLE bit takes one instruction cycle to get cleared after ABAUD is set.	X	X
UART	TXWRE	17.	The TXWRE bit (UxSTAH[7]) cannot be cleared once it gets set.	X	X
UART	Address Detect	18.	When writing to UxP1 with UTXBRK = 1, the content of P1 will not get transmitted.	X	X
UART	DMX	19.	Removed.		
UART	DMX	20.	Removed.		
UART	Smart Card	21.	The Waiting Time Counter Interrupt Flag (WTCIF) is set when the last x character transmitted has the bit, LAST = 0.	X	X
UART	XOFF	22.	XOFF is transmitted when one empty space remains in the RX buffer.	X	X
CPU	FLIM Instruction	23.	When the operands are of different signs, the FLIM instruction may not force the correct data limit.	X	X
SCCP/MCCP	Clock Source	24.	Using FOSC as the clock source may cause synchronization issues.	X	X
I ² C	SMBus 3.0	25.	When Configuration bit, SMBEN (FDEVOPT[10]) = 1, the SMBus 3.0 VIH minimum specification may not be met.	X	X
I/O	POR	26.	Spike on I/O at POR.	X	
CPU	MAXAB/MINAB Instructions	27.	When the operands are of different signs, the MAXAB, MINAB and MINZAB instructions may not output the correct value.	X	X
CPU	div.sd Instruction	28.	When using the signed 32-by-16-bit division instruction, div.sd, the Overflow bit is not getting set when an overflow occurs.	X	X
DMA	ADC Triggers	29.	DMA is triggered continuously from ADC.	X	
PWM	Time Base Capture	30.	PWM Capture Status (CAP) flag will not set again under certain conditions.	X	X

dsPIC33CH128MP508

TABLE 2: SILICON ISSUE SUMMARY (CONTINUED)

Module	Feature	Item Number	Issue Summary	Affected Revisions	
				A2	B0
I ² C	I ² C	31.	All instances of I ² C may exhibit errors and should not be used.	X	
Oscillator	VCO and AVCO Dividers	32.	Main and auxiliary PLL external VCO dividers can fail to output the clock signal.	X	
Main Secondary Interface (MSI)	DMA Transfer	33.	DMA transfer of mailbox data.	X	X
Secondary CPU	REPEAT	34.	REPEAT loops interrupted by nested interrupts on the Secondary core may corrupt data and trap.	X	X
UART	TXWRE	35.	TXWRE bit is not cleared when transmitter is disabled.	X	X
Secondary CPU	PRAM ECC	36.	Secondary core CPU may read from unprogrammed PRAM location.	X	X
SCCP	CCP Timer Interrupt	37.	In Capture mode, the CCPx Timer Interrupt, _CCTxInterrupt, may not occur if the Timer Prescale (TMRPS[1:0]) value is not configured for 1:1 operation.	X	X
ADC	Differential-Mode	38.	When using ADC in Differential-mode (DIFFx = 1) with input frequency (FSRC) above 50 MHz, the first result data may be incorrect.	X	X
POR	ECC	39.	During power-up (POR Reset), an ECC trap or interrupt may occur.	X	X

Silicon Errata Issues

Note: This document summarizes all silicon errata issues from all revisions of silicon, previous as well as current. Only the issues indicated by the shaded column in the following tables apply to the current silicon revision (**B0**).

1. Module: ECC

The ECCSTATH/L registers cannot be read when an ECC error happens. The ECC Double-Bit Error (ECCDBE) trap and ECC Single Bit Error (ECCSBE) interrupt will work correctly, but the ECCSTATH/ECCSTATL registers will always read as zero.

Work around

None.

Affected Silicon Revisions

Core	A2	B0	
Main	X		
Secondary			

2. Module: ECC

In the ECCSTATH register, the SECSYNDx bits cannot be read when an ECC error happens.

Work around

None.

Affected Silicon Revisions

Core	A2	B0	
Main			
Secondary	X		

3. Module: I²C

In Client mode with DHEN = 1 (Data Hold Enable), if software sends a NACK, a Client interrupt is asserted at the 9th falling edge of the clock.

Work around

Software should ignore the Client interrupt that is asserted after sending a NACK.

Affected Silicon Revisions

Core	A2	B0	
Main	X	X	
Secondary	X	X	

4. Module: I²C

In Client mode, the Bus Collision Detect (BCL) bit cannot be cleared when bus collision detection is enabled (SBCDE = 1).

Work around

Disable the I²C module and then re-enable the module.

Affected Silicon Revisions

Core	A2	B0	
Main	X	X	
Secondary	X	X	

5. Module: I²C

In Client mode, false bus collision triggers are generated when the bus collision is enabled (SBCDE = 1) and a Stop bit is received.

Work around

Ignore the bus collision. Disable the I²C module and then re-enable the module.

Affected Silicon Revisions

Core	A2	B0	
Main	X	X	
Secondary	X	X	

6. Module: I²C

In Client mode, an address cannot be received when the device is in Idle and the module is set for discontinue in Idle (I2CSIDL = 1).

Work around

None.

Affected Silicon Revisions

Core	A2	B0	
Main	X	X	
Secondary	X	X	

7. Module: Oscillator

When using the 8 MHz internal FRC Oscillator with Primary PLL as either a system clock or a peripheral source, FRCDIVN drives the PLL instead of the FRC.

This means that the PLL FRC input selection is subject to the FRCDIV[2:0] bits and could lead to a condition where the minimum PLL input requirement of 8 MHz is not maintained.

Work around

Ensure FRCDIV[2:0] bits are maintained as zero when using FRCPLL as either a system clock or a peripheral source.

Affected Silicon Revisions

Core	A2	B0	
Main	X	X	
Secondary	X	X	

8. Module: Oscillator

This errata is no longer applicable to any silicon revisions of this product. See **Section 2.5 “External Oscillator Pins”** in the current device data sheet (DS70005319D) for guidance on oscillator design to avoid start-up related issues.

9. Module: PWM

When feed-forward PCI is used for dead-time compensation (DTCMPSEL = 1), the PWMx outputs are overridden.

Work around

Use Sync PCI (DTCMPSEL = 0) for dead-time compensation.

Affected Silicon Revisions

Core	A2	B0	
Main	X	X	
Secondary	X	X	

10. Module: UART

Once the UART receive buffer overflows and the OERR bit (UxSTA[1]) is set, the OERR bit cannot be cleared by software.

Work around

Make sure that the receive buffer never overflows. Do not let the OERR bit get set by reading the received data byte on each byte reception.

Affected Silicon Revisions

Core	A2	B0	
Main	X	X	
Secondary	X	X	

11. Module: UART

When the UART is operating with STSEL[1:0] = 2 (two Stop bits sent, two checked at receive), the FERR bit will not get set if one Stop bit is received.

Work around

Use STSELx = 3 instead of STSELx = 2. When operating with STSELx = 3 mode, the UART will be configured to send two Stop bits, but check one at receive.

Affected Silicon Revisions

Core	A2	B0	
Main	X	X	
Secondary	X	X	

12. Module: UART

When the receive buffer overflows, the 9th byte received will get lost and cannot be read.

Work around

Do not allow the OERR bit to get set by reading the received data byte on each byte reception.

Affected Silicon Revisions

Core	A2	B0	
Main	X	X	
Secondary	X	X	

13. Module: UART

At low BRG value, the TRMT bit takes time to set on the last transmit completion, which may result in the transmitted data getting lost.

Work around

1. Use the UTXBE bit to monitor for the next transmit.
2. Provide a delay to stabilize the POSC.

Affected Silicon Revisions

Core	A2	B0	
Main	X	X	
Secondary	X	X	

14. Module: UART

The Transmit Shifter Empty (TRMT) bit is unreliable when there is back-to-back Break character transmission.

Work around

Poll the UART Transmit Break bit, UTXBRK (UxMODE[8]), to be cleared instead of the TRMT bit.

Affected Silicon Revisions

Core	A2	B0	
Main	X	X	
Secondary	X	X	

15. Module: UART

UART will not work correctly in Sleep mode. SLPEN = 1 will not keep the UART baud rate clock active in Sleep mode.

Work around

None.

Affected Silicon Revisions

Core	A2	B0	
Main	X	X	
Secondary	X	X	

16. Module: UART

During a UART Auto-Baud Detection sequence, the RIDLE bit takes one instruction cycle to get cleared after ABAUD is set.

Work around

Ignore the RIDLE bit until the Auto-Baud Detection sequence is complete.

Affected Silicon Revisions

Core	A2	B0	
Main	X	X	
Secondary	X	X	

17. Module: UART

Once the TX Write Transmit Error Status bit, TXWRE (UxSTAH[7]), gets set, the TXWRE cannot be cleared by a single clear instruction.

Work around

Use multiple clear instructions of loop until the TXWRE bit gets cleared.

Affected Silicon Revisions

Core	A2	B0	
Main	X	X	
Secondary	X	X	

18. Module: UART

In UART Address Detect mode, writing to UxP1 with UTXBRK = 1 should cause a Break to be transmitted, followed by the content in P1, but the content of P1 will not get transmitted.

Work around

After writing to P1, wait for UTXBRK to get clear and then rewrite to P1.

Affected Silicon Revisions

Core	A2	B0	
Main	X	X	
Secondary	X	X	

19. Module: UART

This errata is no longer applicable to any silicon revisions of this product.

20. Module: UART

This errata is no longer applicable to any silicon revisions of this product.

dsPIC33CH128MP508

21. Module: UART

In Smart Card T = 1 mode, the Wait Time Counter Interrupt Flag (WTCIF) is set when the last character transmitted has the LAST bit = 0.

Work around

Ignore WTC interrupt events on non-last bytes.

Affected Silicon Revisions

Core	A2	B0	
Main	X	X	
Secondary	X	X	

22. Module: UART

In Software Flow Control mode, XOFF is transmitted when one empty space remains in the RX buffer. XOFF transmission can get further delayed if the transmitter has already been loaded, resulting in XOFF transmission on a receive buffer full event.

Work around 1

Give a minimum one-byte delay before each byte transmission.

Work around 2

Use the UART RX interrupt with URXISEL[2:0] set to at least two empty slots. This allows the RX buffer to be read in time to prevent RX buffer overflow.

Affected Silicon Revisions

Core	A2	B0	
Main	X	X	
Secondary	X	X	

23. Module: CPU

The FLIM instruction may incorrectly limit the data range when operating on signed operands of different sign values. If the operands are either all negative or all positive, the limit is correct.

Work around

None.

Affected Silicon Revisions

Core	A2	B0	
Main	X	X	
Secondary	X	X	

24. Module: SCCP/MCCP

When FOSC is selected as the clock source using the CLKSEL[2:0] bits (CCPxCON1L[10:8]), unexpected operation may occur. For proper SCCP/MCCP input clock synchronization, do not use FOSC as the system clock source.

Work around

Use any of the other available clock sources in CLKSEL[2:0].

Affected Silicon Revisions

Core	A2	B0	
Main	X	X	
Secondary	X	X	

25. Module: I²C

When selecting SMBus 3.0 operation using Configuration bit, SMBEN (FDEVOPT[10]), the Voltage Input High (V_{IH}) of the SMBus 3.0 specification minimum may not be met.

Work around

None.

Affected Silicon Revisions

Core	A2	B0	
Main	X	X	
Secondary	X	X	

26. Module: I/O

During a fast device power-up, when the VDD ramp is less than 4 mS, the I/O pins may drive up to 100 μ A current for a duration of up to 10 μ S (Figure 1).

FIGURE 1: I/O RAMP

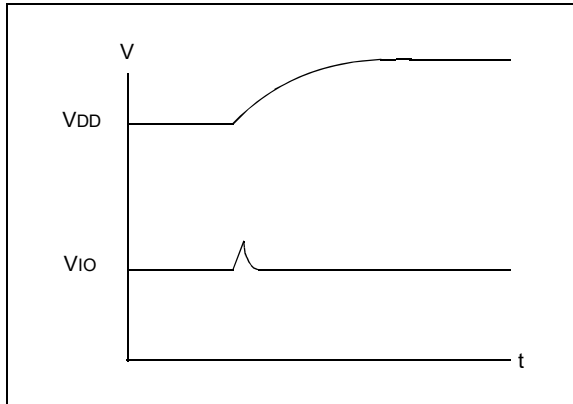

Work around

1. Slow down the VDD ramp time (greater than 4 mS for VDD to ramp 0V to 3.3V).
2. Ensure the circuitry that is connected to the pins can endure this pulse.

Example applications affected may include complementary power switches, where a transient current shoot-through might occur.

High-voltage applications with complementary switches should power the high-voltage 200 μ Sec later than powering the dsPIC[®] device to avoid the current shoot-through. This behavior is specific to each device and not affected by aging.

Affected Silicon Revisions

Core	A2	B0	
Main	X		
Secondary	X		

27. Module: CPU

When operating on signed operands of different sign values, the output for MAXAB, MINAB and MINZAB instructions may be incorrect. If the operands are either all negative or all positive, the output is correct.

Work around

None.

Affected Silicon Revisions

Core	A2	B0	
Main	X	X	
Secondary	X	X	

28. Module: CPU

When using the Signed 32-by-16-Bit Division instruction, DIV.SD, the Overflow bit may not always get set when an overflow occurs. This erratum only affects operations in which at least one of the following conditions is true:

- Dividend and divisor differ in sign,
- Dividend > 0x3FFFFFFF or
- Dividend < 0xC0000000

Work around

The application software must perform both of the following actions to handle possible undetected overflow conditions:

- a) The value of the dividend must always be constrained to be in the following range: $0xC0000000 \leq \text{Dividend} \leq 0x3FFFFFFF$.
- b) If the dividend and divisor differ in sign (e.g., dividend is negative and divisor is positive), then after executing the DIV.SD instruction or the compiler built-in function, `__builtin_divsd()`, inspect the sign of the resultant quotient. If the quotient is found to be a positive number, then treat it as an overflow condition.

Affected Silicon Revisions

Core	A2	B0	
Main	X	X	
Secondary	X	X	

29. Module: DMA

The DMA receives multiple continuous triggers from the ADC until the trigger event from ADC is cleared. The OVRUNIF flag (DMAINTn[3]) will be set. When the OVRUNIF bit changes state, from '0' to '1', a DMA interrupt is generated.

Work around

Ignore the OVRUNIF bit and the first DMA interrupt. Clear the ADC trigger source, ANxRDY, with a DMA read of the ADC buffer, ADCBUFx, for the corresponding ADC channel.

Affected Silicon Revisions

Core	A2	B0	
Main	X		
Secondary	X		

30. Module: PWM

When using a PWM Control Input (PCI) to trigger a time base capture, the Capture Status flag, CAP (PGxSTAT[5]), may not set again under certain conditions. When a subsequent PWM capture event occurs while, or just after, reading the current capture value from the PGxCAP register, the Capture Status flag, CAP, will not set again.

Work around

Read the PWM Generator Capture (PGxCAP, x = 1 to 8) register at a known time to avoid the condition. The timing of the PGxCAP read operation can be scheduled by using the PWM Generator (1-8) interrupt, or any of the six PWM Event (A-F) interrupts, corresponding to the PCI event which triggered the time base capture. Read the PGxCAP value after the CAP bit has been set within the interrupt.

Affected Silicon Revisions

Core	A2	B0	
Main	X	X	
Secondary	X	X	

31. Module: I²C

All instances of I²C/SMBus may exhibit errors and should not be used. When operating I²C/SMBus in a noisy environment, the I²C module may exhibit various errors. These errors may include, but are not limited to, corrupted data, unintended interrupts or the I²C bus getting hung up due to injected noise. Examples of system noise include, but are not limited to, PWM outputs or other pins toggled at high speed adjacent to the I²C pins. Both Host and Client I²C/SMBus modes may exhibit this issue.

Work around

If I²C is required, use a software I²C implementation. An example I²C software library is available from Microchip:

www.microchip.com/dsPIC33C_I2C_SoftwareLibrary

Affected Silicon Revisions

Core	A2	B0	
Main	X		
Secondary	X		

32. Module: Oscillator

At PLL start-up, the main and auxiliary PLL VCO dividers may occasionally halt and not provide a clock output. The VCO and AVCO dividers can be selected as clock sources for different peripheral modules, including the ADC, PWM, DAC, CAN FD, UART, etc.

All VCO and AVCO divider outputs, Fvco/2, Fvco/3, Fvco/4, FVCODIV, AFvco/2, AFvco/3, AFvco/4 and AFVCODIV, are affected and may show the issue independently.

Any type of Reset may recover the VCO/AVCO divider clock outputs (Software Reset, WDT, MCLR or POR).

Work around 1

Use another clock source, such as the FOSC, PLL or APLL output (FPLLO and AFPLLO), instead of the VCO or AVCO dividers.

Work around 2

If the application requires the VCO/AVCO divider, peripheral activity should be verified within some time or the device should be Reset.

The Watchdog Timer (WDT) or Timer1 may be used to establish the time-out period and reset the device. The following steps may be taken to implement this work around for any given peripheral and VCO/AVCO divider combination.

- 1) Set up the WDT or Timer1 time-out period.
- 2) Set up the VCO/AVCO divider source to be used by the peripheral.
- 3) Start the peripheral from this source.
- 4) Verify peripheral activity using an interrupt or other method and disable the time-out.
- 5) If the time-out expires, the device should be reset; WDT will reset the device without intervention, but Timer1 will require a SWR in the Timer1 Interrupt Service Routine.

Affected Silicon Revisions

Core	A2	B0	
Main	X		
Secondary	X		

33. Module: Main Secondary Interface (MSI)

When transferring data between cores using the MSI mailbox with DMA, if the transmitting core is running more than two times the system clock frequency of the receiving core, the data transfer may not be processed correctly and the MSI may appear to be in a Freeze state.

An example of the application includes the DMA in the transmitting core may load data to the MSI Mailbox register after the receiving core initiates the MSI interrupt to Acknowledge data reception, but prior to hardware clear of the DTRDY bit, causing the hardware to appear to be frozen in the state where DTRDY is set in the transmitting core and cleared in the receiving core.

Work around

Do not use DMA for MSI data transfer when the core sending data will be operating at more than two times the system clock frequency of the core receiving data. Instead, in the MSI ISR, clear the DTRDY bit and load the next data to the MSI buffer/FIFO directly.

Affected Silicon Revisions

Core	A2	B0	
Main	X	X	
Secondary	X	X	

34. Module: Secondary CPU

While the Secondary CPU core is executing the instruction targeted by a REPEAT loop and two or more nestable interrupts occur in near simultaneous proximity, data corruption may occur within the lowest priority Interrupt Service Routine (ISR) and/or original REPEAT loop code. Specifically, when the CPU is vectoring to the lower priority ISR and a higher priority stimulus forces the CPU to vector to a different ISR, hardware will retarget the background REPEAT loop onto the first instruction of the lower priority ISR. Typically, ISRs start with a stack PUSH instruction, resulting in repeated stack pushes later when the lower priority ISR executes. This manifests as an Address Error Trap upon return from the low-priority ISR as the CPU attempts to use the repeated stack push data as the ISR's return address.

If the first instruction of the lower priority ISR is repeatable without harmful effects, such as a NOP, data corruption will still be apparent in the background code as its REPEAT loop will prematurely terminate.

Work around 1

Avoid using REPEAT instructions in projects built for the Secondary Core. For compiled code, use MPLAB® XC16, v1.61 or higher and specify `-merrata=repeat_gie` or `-merrata=repeat_nstdis` as an additional option for XC16 (Global Options). Alternatively, this option may be individually added to the command-lines invoking `xc16-gcc` and `xc16-ld`.

`-merrata=repeat_gie` will suppress generation of REPEAT loops unless required for a hardware divide instruction. For divides, the REPEAT loop will be prefixed with instructions to save INTCON2. Write `GIE (INTCON2[15]) = 0` to globally disable all interrupts, then postfix with an instruction to restore INTCON2. Toolchain library calls, such as `memcpy()/printf()`, etc., will also link against implementations that avoid REPEAT loops and globally mask interrupts where needed for divide instructions.

`-merrata=repeat_nstdis` will also suppress REPEAT loops. However, for hardware divide loops, saving/restoring will be applied to INTCON1 and NSTDIS (`INTCON1[15] = 1`) will be written to disable interrupt nesting while maintaining GIE unchanged. Toolchain libraries will continue to use GIE (`INTCON2[15]`) global interrupt masking instead of relying on NSTDIS (`INTCON1[15]`) to protect divide loops.

Note: Blocking interrupt nesting typically adds no latency to interrupt processing, but increases worst-case interrupt latency for higher priority ISRs. A low-priority interrupt triggered immediately before a high-priority stimulus adds the entire execution time of the low-priority ISR to the worst-case response latency for the higher priority ISR.

Work around 2

Ensure that all REPEAT instructions only execute in a context where back-to-back interrupts of nestable priority are impossible, such as within IPL6 and IPL7 ISRs, or anywhere all enabled interrupts are known to be configured to the same priority level. Also, if the application implements periodic interrupts corresponding to internal/synchronously timed events, it may be possible to find or wait for an execution window where a REPEAT loop can deterministically complete without two nested interrupts able to clobber it. A PWRSAV call to enter Idle mode may help find synchronized, safe windows as code flow will halt, then resume in response to the next interrupt.

As compiled code can have REPEAT loops hidden within them, this work around should only be attempted on a per source file basis with Work around 1 applied for all other files that cannot be carefully controlled or which do not require REPEAT loops. It is additionally suggested that the full project disassembly listing be searched for REPEAT instructions and that proper interrupt masking, nest disabling or contextual state and timing conditions for safe REPEAT execution have been met.

Affected Silicon Revisions

Core	A2	B0	
Main	X	X	
Secondary	X	X	

35. Module: UART

The TXWRE bit is not cleared when the UART transmitter is disabled.

Work around

The user must flush the FIFO via writing TXBE = 1 first and then the TXWRE bit can be cleared.

Affected Silicon Revisions

Core	A2	B0	
Main	X	X	
Secondary	X	X	

36. Module: Secondary CPU

If transferring data using the DMA with DMAPR (MSTRPR[5]) = 1 (DMA priority higher than CPU) and an interrupt occurs, the Secondary CPU, "cpu_pmem_addr", may be corrupted with the DMA data before fetching the proper RETFIE return address. If the DMA data correspond to the address of an unprogrammed location in the PRAM, ECC single-bit and double-bit errors may be observed.

Work around

A routine, called "_wipe_secondary(1);", has been added in MPLAB® XC16 v1.70 or higher and requires the MPLAB IDE device family pack, dsPIC33CH-MP 1.9.207 or higher. This routine will load the PRAM with a known value and valid ECC contents. The Main core application should call this routine at least once each time the device is powered on and should do so before loading the PRAM with the Secondary core user application image.

The time needed to run the "_wipe_secondary(1);" routine is Main core execution speed-dependent, but will be similar to loading a full size image to a PRAM of a given size.

Affected Silicon Revisions

Core	A2	B0	
Main			
Secondary	X	X	

37. Module: SCCP

In Capture mode, the CCPx Timer Interrupt, _CCTxInterrupt, may not occur if the Timer Prescale (TMRPS[1:0]) value is not configured for 1:1 operation.

Work around

If the _CCTxInterrupt is needed in Capture mode, maintain TMRPS[1:0] = 00 for 1:1 timer prescale.

Affected Silicon Revisions

Core	A2	B0	
Main	X	X	
Secondary	X	X	

38. Module: ADC

When using ADC in Differential-mode (DIFFx = 1) with Input Frequency (FSRC) above 50 MHz, the first result data may be incorrect. The Single-Ended Channel mode is unaffected by this errata.

Work around

Use a slower input frequency of 50 MHz or less for the ADC initialization to write to the ADMODxL/H registers. After completion of the first data conversion of each channel in Differential-mode, the Input Frequency, FSRC, can be increased to the maximum specified frequency in the electrical characteristics.

Affected Silicon Revisions

Core	A2	B0	
Main	X	X	
Secondary	X	X	

39. Module: POR

In an extremely rare situation, during power-up (POR Reset), an unintended ECC trap or ECC interrupt may occur.

Work around

Any one of the following work arounds can be implemented to resolve the issue:

1. Execute a software `RESET` instruction after a POR Reset. The POR condition can be verified by reading the POR bit (RCON[0]). The POR test and `RESET` instruction can be located in the generic Hard Trap Service Routine, which contains the ECC double-bit error, as well as in the ECC Single-Bit Error Interrupt Service Routine.
2. An external `MCLR` Reset supervisor circuit can be used to hold the device in Reset during POR and released after the VDD is above 3V.
3. Ensure the VDD rise rate is at least 0.03 V/μS (0 to 3.0V in 100 μS). VDD rise from 0V to 3.0V minimum operating voltage should take no longer than 100 μS.

Affected Silicon Revisions

Core	A2	B0	
Main	X	X	
Secondary	X	X	

dsPIC33CH128MP508

Data Sheet Clarifications

The following typographic corrections and clarifications are to be noted for the latest version of the device data sheet (DS70005319D):

Note: Corrections are shown in **bold**. Where possible, the original bold text formatting has been removed for clarity.

1. Module: Electrical Characteristics

In [Table 24-29](#), the FRC percentage is changed from -3 to +3, to -2 to +2 and Note 2 has been added. All changes are shown below in **bold**.

2. Module: Functional Safety and Qualification Support

Functional Safety

- Class B Safety Library – IEC 60730
- For ASIL B and Beyond Applications – ISO 26262
- FMEDA Computation Spreadsheet (evaluation of Random Hardware Failures Metric)
- Functional Safety Manual
- Functional Safety Diagnostics Suite

Qualification Support

- AEC-Q100 REV-H
(Grade 0: -40°C to +150°C) Compliant

TABLE 24-29: INTERNAL FRC ACCURACY

Operating Conditions: 3.0V to 3.6V (unless otherwise stated)					
Operating temperature -40°C ≤ TA ≤ +85°C for Industrial					
-40°C ≤ TA ≤ +125°C for Extended					
Param No.	Characteristic	Min.	Max.	Units	Conditions
Internal FRC Accuracy @ FRC Frequency = 8 MHz⁽¹⁾					
F20a	FRC	-2⁽²⁾	+2	%	-40°C ≤ TA ≤ -5°C
		-1.5	+1.5	%	-5°C ≤ TA ≤ +85°C
		-2	+2	%	+85°C ≤ TA ≤ +125°C
F22	BFRC	-17	+17	%	-40°C ≤ TA ≤ +125°C

Note 1: Frequency is calibrated at +25°C and 3.3V. TUNx bits can be used to compensate for temperature drift.

2: Due to the effect of aging, this value may drift by an additional -0.5% over the lifetime of the device.

3. Module: Guidelines for Getting Started with 16-Bit Digital Signal Controllers

Additional information is added to [Section 2.5 “External Oscillator Pins”](#) and [Section 2.6 “External Oscillator Layout Guidance”](#) is added.

2.5 External Oscillator Pins

When the Primary Oscillator (POSC) circuit is used to connect a crystal oscillator, special care and consideration is needed to ensure proper operation. The POSC circuit should be tested across the environmental conditions that the end product is intended to be used. The load capacitors specified in the crystal oscillator data sheet can be used as a starting point, however, the parasitic capacitance from the PCB traces can affect the circuit and the values may need to be altered to ensure proper start-up and operation.

Excessive trace length and other physical interaction can lead to poor signal quality. Poorly tuned oscillator circuits can have reduced amplitude, incorrect frequency (runt pulses), distorted waveforms and long start-up times that may result in unpredictable application behavior, such as instruction misexecution, illegal op code fetch, etc. Ensure that the crystal oscillator circuit is at full amplitude and correct frequency before the system begins to execute code. In planning the application's routing and I/O assignments, ensure that adjacent port pins, and other signals in close proximity to the oscillator, do not have high frequencies, short rise and fall times and other similar noise. For further information on the Primary Oscillator, see Primary Oscillator (POSC).

2.6 External Oscillator Layout Guidance

Use best practices during PCB layout to ensure robust start-up and operation. The oscillator circuit should be placed on the same side of the board as the device. Also, place the oscillator circuit close to the respective oscillator pins, not exceeding one-half inch (12 mm) distance between them. The load capacitors should be placed next to the oscillator itself, on the same side of the board. Use a grounded copper pour around the oscillator circuit to isolate it from surrounding circuits. The grounded copper pour should be routed directly to the MCU ground. Do not run any signal traces or power traces inside the ground pour. If using a two-sided board, avoid any traces on the other side of the board where the crystal is placed. Suggested layouts are shown in [Figure 2-2](#). With fine-pitch packages, it is not always possible to completely surround the pins and components. A suitable solution is to tie the broken guard sections to a mirrored ground layer. In all cases, the guard trace(s) must be returned to ground.

For additional information and design guidance on oscillator circuits, please refer to these Microchip Application Notes, available at the Microchip website (www.microchip.com):

- AN943, “*Practical PICmicro® Oscillator Analysis and Design*”
- AN949, “*Making Your Oscillator Work*”
- AN1798, “*Crystal Selection for Low-Power Secondary Oscillator*”

dsPIC33CH128MP508

FIGURE 2-2: SUGGESTED PLACEMENT OF THE OSCILLATOR CIRCUIT

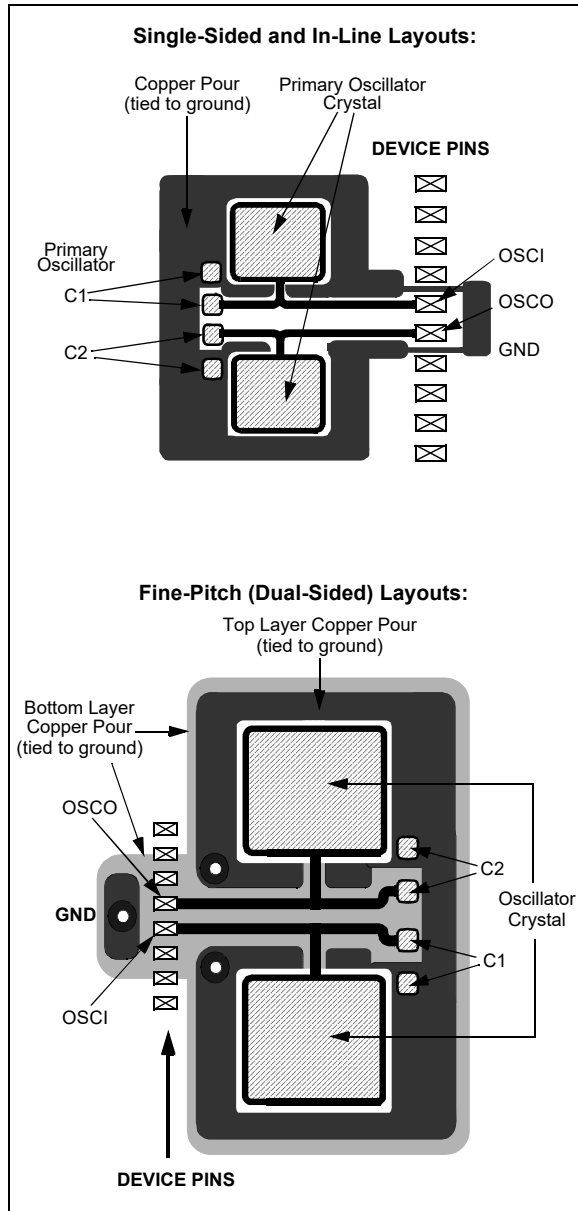

4. Module: dsPIC® Core Naming Convention

When referring to the dsPIC cores implemented in a dual core device, all instances of “Master” and “Slave” have been replaced with “Main” and “Secondary”, respectively. This includes the Master Slave Interface (MSI) module which is now named the Main Secondary Interface (MSI) module.

5. Module: UART

All references to support for UART DMX mode of operation have been removed.

This feature is not supported by this family of devices.

6. Module: SPI

The following text in the second paragraph of the SPI section: “One of the SPI modules can work up to 50 MHz speed when selected as a non-PPS pin. For the Master core, it will be SPI2 and for the Slave core, it will be SPI1.”

Has been changed to:

“On 48, 64 and 80-pin devices, one of the SPI modules can operate at higher speeds when selected as a non-PPS pin. For the Main core, it will be SPI2 and for the Secondary core, it will be SPI1.”

7. Module: Oscillator

Table 6-3 has been updated as shown below in **bold**.

TABLE 6-3: OSCO FUNCTION FOR THE **MAIN** AND **SECONDARY** CORE⁽¹⁾

[OSCIOFNC:S1OSCIOFNC]	RB1 or OSCO pin function
1:1	Main clock output on OSCO pin
1:0	Main clock output on OSCO pin
0:1	Secondary clock output on OSCO pin
0:0	Clock out disabled, RB1 works as an I/O port; output function is based on pin ownership (CPRB1 = 1 or 0)

Note 1: The RB1 pin will toggle during programming or debugging time, irrespective of the OSCIOFNC or S1OSCIOFNC settings.

8. Module: Electrical Characteristics

AD60, AD61 and AD62 have been added to Table 24-43 as shown below in **bold**.

TABLE 24-43: ADC MODULE SPECIFICATIONS

Operating Conditions: 3.0V to 3.6V (unless otherwise stated)							
Operating temperature -40°C ≤ TA ≤ +85°C for Industrial							
-40°C ≤ TA ≤ +125°C for Extended							
Param No.	Symbol	Characteristics	Min.	Typical	Max.	Units	Conditions
Analog Input							
AD12	V _{INH-VINL}	Full-Scale Input Span	AV _{SS}	—	AV _{DD}	V	
AD14	V _{IN}	Absolute Input Voltage	AV _{SS} - 0.3	—	AV _{DD} + 0.3	V	
AD60	CHOLD	Sample-and-Hold Capacitance	—	5	—	pF	Dedicated cores
AD61	CHOLD	Sample-and-Hold Capacitance	—	15	—	pF	Shared core
AD62	R_{IC}	Internal Interconnection Resistance	—	—	1000	Ω	
AD66	V _{BG}	Internal Voltage Reference Source	1.14	1.2	1.26	V	

dsPIC33CH128MP508

9. Module: ADC

The following [Sampling Time Requirements](#) section has been added to both **Section 3.9** “High-Speed, 12-Bit Analog-to-Digital Converter (Main Core ADC)” and **Section 4.7** “High-Speed, 12-Bit Analog-to-Digital Converter (Secondary Core ADC)”.

Sampling Time Requirements

The analog input model of the ADC is shown in the figure below.

FIGURE: ADC ANALOG INPUT MODEL

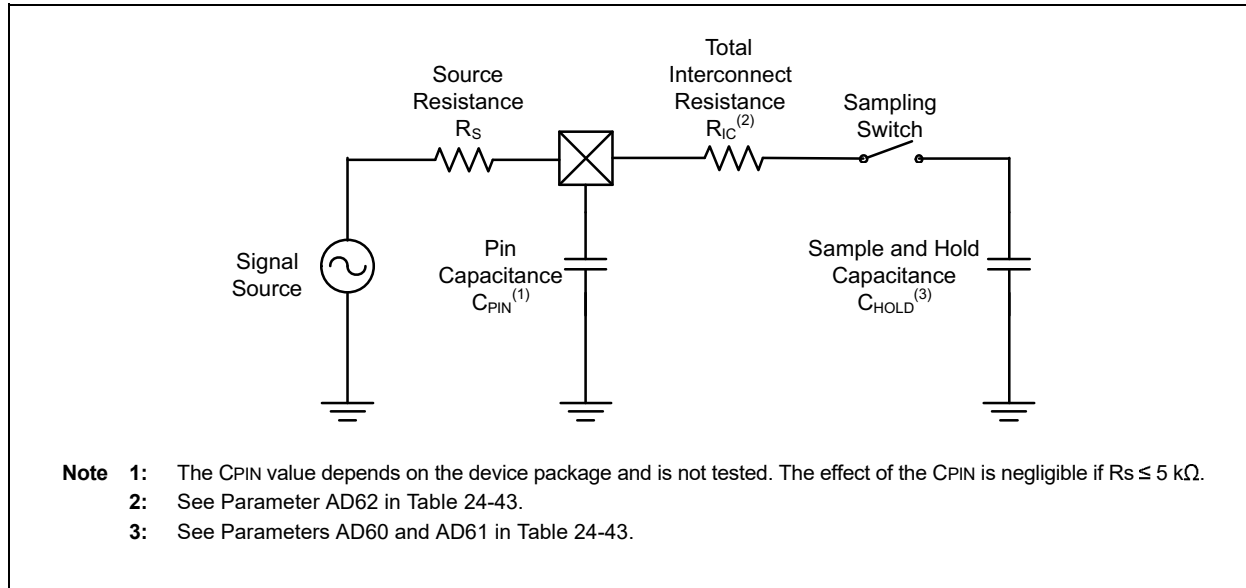

The total acquisition time for the Analog-to-Digital conversion is a function of the Holding Capacitor (C_{HOLD}) charge time. For the ADC module to meet its specified accuracy, the Holding Capacitor (C_{HOLD}) must be allowed to fully charge to the voltage level on the analog input pin. The Signal Source Impedance (R_S)

and the Interconnect Impedance (R_{IC}) combine to affect the time required to charge the C_{HOLD} . The total resistance ($R_S + R_{IC}$) must therefore, be small enough to fully charge the Holding Capacitor within the selected sample time.

10. Module: DAC

The following changes have been made to [Table 3-31](#) as shown below in **bold**.

TABLE 3-31: **MAIN CORE REMAPPABLE PIN INPUTS**

RPINRx[15:8] or RPINRx[7:0]	Function	Available on Ports
168	DAC1 pwm_req_on	Internal
169	DAC1 pwm_req_off	Internal

TABLE 4-27: **SECONDARY CORE REMAPPABLE PIN INPUTS**

RPINRx[15:8] or RPINRx[7:0]	Function	Available on Ports
162	DAC3 pwm_req_on	Internal
163	DAC3 pwm_req_off	Internal
164	DAC2 pwm_req_on	Internal
165	DAC2 pwm_req_off	Internal
166	DAC1 pwm_req_on	Internal
167	DAC1 pwm_req_off	Internal

11. Module: PTG

The following changes have been made to [Table 3-47](#) as shown below in **bold**.

TABLE 3-47: **PTG INPUT DESCRIPTIONS**

PTG Input Number	PTG Input Description
PTG Trigger Input 0	Trigger Input from Main Core PWM1 ADC Trigger 2
PTG Trigger Input 1	Trigger Input from Main Core PWM2 ADC Trigger 2
PTG Trigger Input 2	Trigger Input from Main Core PWM3 ADC Trigger 2
PTG Trigger Input 3	Trigger Input from Main Core PWM4 ADC Trigger 2
PTG Trigger Input 4	Trigger Input from Secondary Core PWM1 ADC Trigger 2
PTG Trigger Input 5	Trigger Input from Secondary Core PWM2 ADC Trigger 2
PTG Trigger Input 6	Trigger Input from Secondary Core PWM3 ADC Trigger 2

dsPIC33CH128MP508

12. Module: PPS

The following changes have been made to [Table 4-27](#) as shown below in **bold**.

TABLE 4-27: **SECONDARY CORE REMAPPABLE PIN INPUTS**

RPINRx[15:8] or RPINRx[7:0]	Function	Available on Ports
170	S1RP170	Main RPV0
171	S1RP171	Main RPV1
172	S1RP172	Main RPV2
173	S1RP173	Main RPV3
174	S1RP174	Main RPV4
175	S1RP175	Main RPV5
176	S1RP176	Secondary RPV0
177	S1RP177	Secondary RPV1
178	S1RP178	Secondary RPV2
179	S1RP179	Secondary RPV3
180	S1RP180	Secondary RPV4
181	S1RP181	Secondary RPV5

13. Module: Electrical Characteristics

[Table 24-34](#) has been updated as shown below. The maximum data rate column has been deleted, and references to tables and figures have been included to provide more detailed information.

TABLE 24-34: **SPIx MAXIMUM DATA/CLOCK RATE SUMMARY**

SPI Host Transmit Only (Half-Duplex)	SPI Host Transmit/Receive (Full-Duplex)	SPI Client Transmit/Receive (Full-Duplex)	CKE
Figure 24-7 Table 24-35	—	—	0
Figure 24-8 Table 24-35	—	—	1
—	Figure 24-9 Table 24-36	—	0
—	Figure 24-10 Table 24-37	—	1
—	—	Figure 24-12 Table 24-39	0
—	—	Figure 24-13 Table 24-38	1

14. Module: MSTRPR Register

The following register has been added to Section 3.1.7 “Main CPU Control/Status Registers”.

MSTRPR: DATA SPACE BUS MASTER PRIORITY CONTROL REGISTER (MAIN)

U-0	U-0	U-0	U-0	U-0	U-0	U-0	U-0
—	—	—	—	—	—	—	—
bit 15							bit 8

U-0	U-0	R/W-0	R/W-0	U-0	U-0	U-0	R/W-0
—	—	DMAPR	CANPR	—	—	—	NVMPR
bit 7							bit 0

Legend:

R = Readable bit	W = Writable bit	U = Unimplemented bit, read as '0'
-n = Value at POR	'1' = Bit is set	'0' = Bit is cleared
		x = Bit is unknown

- bit 15-6 **Unimplemented:** Read as '0'
- bit 5 **DMAPR:** Modify DMA Controller Bus Master Priority Relative to CPU bit
 - 1 = Raises DMA Controller bus Master priority to above that of the CPU
 - 0 = No change to DMA Controller bus Master priority
- bit 4 **CANPR:** Modify CAN1 Bus Master Priority Relative to CPU bit
 - 1 = Raises CAN1 bus Master priority to above that of the CPU
 - 0 = No change to CAN1 bus Master priority
- bit 3-1 **Unimplemented:** Read as '0'
- bit 0 **NVMPR:** Modify NVM Controller Bus Master Priority Relative to CPU bit
 - 1 = Raises NVM Controller bus Master priority to above that of the CPU
 - 0 = No change to NVM Controller bus Master priority

dsPIC33CH128MP508

15. Module: MSTRPR Register

The following register has been added to Section 4.1.7 “Secondary CPU Control/Status Registers”.

MSTRPR: DATA SPACE BUS MASTER PRIORITY CONTROL REGISTER (SECONDARY)

U-0	U-0	U-0	U-0	U-0	U-0	U-0	U-0
—	—	—	—	—	—	—	—
bit 15							bit 8

U-0	U-0	R/W-0	U-0	U-0	U-0	U-0	U-0
—	—	DMA PR	—	—	—	—	—
bit 7							bit 0

Legend:

R = Readable bit

W = Writable bit

U = Unimplemented bit, read as '0'

-n = Value at POR

'1' = Bit is set

'0' = Bit is cleared

x = Bit is unknown

bit 15-6 **Unimplemented:** Read as '0'

bit 5 **DMA PR:** Modify DMA Controller Bus Master Priority Relative to CPU bit

1 = Raise DMA Controller bus Master priority to above that of the CPU

0 = No change to DMA Controller bus Master priority

bit 4-0 **Unimplemented:** Read as '0'

16. Module: Electrical Characteristics

In **Table 24-4: Operating Voltage specifications**, the DC17 specification, VDD Rise Rate minimum, is updated from 1 V/ms to 0.03 V/ms.

This allows up to 100 ms for VDD to reach the 3V minimum operating voltage.

17. Module: Electrical Characteristics

In Table 24-18, the DI10 and DI20 specifications are updated to include SMBus 3.0 V_{IL} and V_{IH} levels. All changes are shown below in **bold**.

TABLE 24-18: I/O PIN INPUT SPECIFICATIONS

Operating Conditions: 3.0V to 3.6V (unless otherwise stated) Operating temperature $-40^{\circ}\text{C} \leq T_A \leq +85^{\circ}\text{C}$ for Industrial $-40^{\circ}\text{C} \leq T_A \leq +125^{\circ}\text{C}$ for Extended						
Param No.	Symbol	Characteristic	Min.	Max.	Units	Conditions
DI10	V_{IL}	Input Low Voltage				
		Any I/O Pin and $\overline{\text{MCLR}}$	V_{SS}	$0.2 V_{DD}$	V	
		I/O Pins with SDAx, SCLx	V_{SS}	$0.3 V_{DD}$	V	SMBus disabled
		I/O Pins with SDAx, SCLx I/O Pins with SDAx, SCLx	V_{SS} V_{SS}	0.8 0.8	V V	SMBus enabled SMBus 3.0 enabled
DI20	V_{IH}	Input High Voltage				
		I/O Pins Not 5V Tolerant	$0.8 V_{DD}$	V_{DD}	V	
		5V Tolerant I/O Pins and $\overline{\text{MCLR}}$	$0.8 V_{DD}$	5.5	V	
		I/O Pins 5V Tolerant with SDAx, SCLx	$0.8 V_{DD}$	5.5	V	SMBus disabled
		I/O Pins 5V Tolerant with SDAx, SCLx I/O Pins 5V Tolerant with SDAx, SCLx	2.1 1.35	5.5 V_{DD}	V	SMBus enabled SMBus 3.0 enabled
		I/O Pins Not 5V Tolerant with SDAx, SCLx	$0.8 V_{DD}$	V_{DD}	V	SMBus disabled
		I/O Pins Not 5V Tolerant with SDAx, SCLx	2.1	V_{DD}	V	SMBus enabled
		I/O Pins Not 5V Tolerant with SDAx, SCLx	1.35	V_{DD}	V	SMBus 3.0 enabled

dsPIC33CH128MP508

APPENDIX A: DOCUMENT REVISION HISTORY

Rev A Document (5/2018)

Initial release of this document; issued for revision A2.

Rev B Document (11/2018)

Adds silicon issue 23 (CPU), 24 (SCCP/MCCP), 25 (I²C) and 26 (I/O).

Rev C Document (10/2019)

Adds silicon issue 27 (CPU), 28 (CPU), 29 (DMA) and 30 (PWM).

Updates silicon issue 26 (I/O).

Updates device data sheet reference to the current revision D.

Rev D Document (2/2020)

Adds silicon issue 31 (I²C).

Rev E Document (6/2020)

Adds silicon issues 32 (Oscillator) and 33 (Main Secondary Interface (MSI)).

Adds data sheet clarification 1 (Electrical Characteristics).

Removes silicon issue 8 (Oscillator) since it is no longer applicable.

Rev F Document (10/2020)

Updates silicon issue 32 (Oscillator).

Adds silicon issue 34 (Secondary CPU).

Adds data sheet clarifications 2 (Functional Safety and Qualification Support), 3 (Guidelines for Getting Started with 16-Bit Digital Signal Controllers) and 4 (dsPIC[®] Core Naming Convention).

Rev G Document (12/2020)

Adds silicon revision B0.

Corrects the Features in Table 2 for Silicon Revision 10, 11 and 12.

Removes Work Around #2 from silicon issue 10 (UART).

Removes silicon issues 19 (UART) and 20 (UART) since they are no longer applicable. Please see data sheet clarification 5 (UART) for more information.

Changes the MPLAB[®] XC16 version to v1.61 or higher.

Adds silicon issue 35 (UART) and 36 (Secondary CPU).

Adds data sheet clarifications 5 (UART), 6 (SPI), 7 (Oscillator), 8 (Electrical Characteristics), 9 (ADC), 10 (DAC), 11 (PTG), 12 (PPS), 13 (Electrical Characteristics), 14 (MSTRPR Register) and 15 (MSTRPR Register).

Rev H Document (4/2021)

Updates the workaround for silicon issue 36 (Secondary CPU).

Adds silicon issue 37 (SCCP).

Adds data sheet clarifications 16 (Electrical Characteristics) and 17 (Electrical Characteristics).

Rev J Document (8/2021)

Updates silicon issue 36 (Secondary CPU).

Adds silicon issues 38 (ADC) and 39 (POR).

Note the following details of the code protection feature on Microchip devices:

- Microchip products meet the specifications contained in their particular Microchip Data Sheet.
- Microchip believes that its family of products is secure when used in the intended manner and under normal conditions.
- There are dishonest and possibly illegal methods being used in attempts to breach the code protection features of the Microchip devices. We believe that these methods require using the Microchip products in a manner outside the operating specifications contained in Microchip's Data Sheets. Attempts to breach these code protection features, most likely, cannot be accomplished without violating Microchip's intellectual property rights.
- Microchip is willing to work with any customer who is concerned about the integrity of its code.
- Neither Microchip nor any other semiconductor manufacturer can guarantee the security of its code. Code protection does not mean that we are guaranteeing the product is "unbreakable." Code protection is constantly evolving. We at Microchip are committed to continuously improving the code protection features of our products. Attempts to break Microchip's code protection feature may be a violation of the Digital Millennium Copyright Act. If such acts allow unauthorized access to your software or other copyrighted work, you may have a right to sue for relief under that Act.

Information contained in this publication is provided for the sole purpose of designing with and using Microchip products. Information regarding device applications and the like is provided only for your convenience and may be superseded by updates. It is your responsibility to ensure that your application meets with your specifications.

THIS INFORMATION IS PROVIDED BY MICROCHIP "AS IS". MICROCHIP MAKES NO REPRESENTATIONS OR WARRANTIES OF ANY KIND WHETHER EXPRESS OR IMPLIED, WRITTEN OR ORAL, STATUTORY OR OTHERWISE, RELATED TO THE INFORMATION INCLUDING BUT NOT LIMITED TO ANY IMPLIED WARRANTIES OF NON-INFRINGEMENT, MERCHANTABILITY, AND FITNESS FOR A PARTICULAR PURPOSE OR WARRANTIES RELATED TO ITS CONDITION, QUALITY, OR PERFORMANCE.

IN NO EVENT WILL MICROCHIP BE LIABLE FOR ANY INDIRECT, SPECIAL, PUNITIVE, INCIDENTAL OR CONSEQUENTIAL LOSS, DAMAGE, COST OR EXPENSE OF ANY KIND WHATSOEVER RELATED TO THE INFORMATION OR ITS USE, HOWEVER CAUSED, EVEN IF MICROCHIP HAS BEEN ADVISED OF THE POSSIBILITY OR THE DAMAGES ARE FORESEEABLE. TO THE FULLEST EXTENT ALLOWED BY LAW, MICROCHIP'S TOTAL LIABILITY ON ALL CLAIMS IN ANY WAY RELATED TO THE INFORMATION OR ITS USE WILL NOT EXCEED THE AMOUNT OF FEES, IF ANY, THAT YOU HAVE PAID DIRECTLY TO MICROCHIP FOR THE INFORMATION. Use of Microchip devices in life support and/or safety applications is entirely at the buyer's risk, and the buyer agrees to defend, indemnify and hold harmless Microchip from any and all damages, claims, suits, or expenses resulting from such use. No licenses are conveyed, implicitly or otherwise, under any Microchip intellectual property rights unless otherwise stated.

Trademarks

The Microchip name and logo, the Microchip logo, Adaptec, AnyRate, AVR, AVR logo, AVR Freaks, BesTime, BitCloud, chipKIT, chipKIT logo, CryptoMemory, CryptoRF, dsPIC, FlashFlex, flexPWR, HELDO, IGL00, JukeBlox, KeeLoq, Kleer, LANCheck, LinkMD, maXStylus, maXTouch, MediaLB, megaAVR, Microsemi, Microsemi logo, MOST, MOST logo, MPLAB, OptoLyzer, PackeTime, PIC, picoPower, PICSTART, PIC32 logo, PolarFire, Prochip Designer, QTouch, SAM-BA, SenGenuity, SpyNIC, SST, SST Logo, SuperFlash, Symmetricom, SyncServer, Tachyon, TimeSource, tinyAVR, UNI/O, Vectron, and XMEGA are registered trademarks of Microchip Technology Incorporated in the U.S.A. and other countries.

AgileSwitch, APT, ClockWorks, The Embedded Control Solutions Company, EtherSynch, FlashTec, Hyper Speed Control, HyperLight Load, IntelliMOS, Libero, motorBench, mTouch, Powermite 3, Precision Edge, ProASIC, ProASIC Plus, ProASIC Plus logo, QuietWire, SmartFusion, SyncWorld, Temux, TimeCesium, TimeHub, TimePictra, TimeProvider, WinPath, and ZL are registered trademarks of Microchip Technology Incorporated in the U.S.A.

Adjacent Key Suppression, AKS, Analog-for-the-Digital Age, Any Capacitor, AnyIn, AnyOut, Augmented Switching, BlueSky, BodyCom, CodeGuard, CryptoAuthentication, CryptoAutomotive, CryptoCompanion, CryptoController, dsPICDEM, dsPICDEM.net, Dynamic Average Matching, DAM, ECAN, Espresso T1S, EtherGREEN, IdealBridge, In-Circuit Serial Programming, ICSP, INICnet, Intelligent Paralleling, Inter-Chip Connectivity, JitterBlocker, maxCrypto, maxView, memBrain, Mindi, MiWi, MPASM, MPF, MPLAB Certified logo, MPLIB, MPLINK, MultiTRAK, NetDetach, Omniscient Code Generation, PICDEM, PICDEM.net, PICkit, PICtail, PowerSmart, PureSilicon, QMatrix, REAL ICE, Ripple Blocker, RTAX, RTG4, SAM-ICE, Serial Quad I/O, simpleMAP, SimpliPHY, SmartBuffer, SMART-I.S., storClad, SQI, SuperSwitcher, SuperSwitcher II, Switchtec, SynchroPHY, Total Endurance, TSHARC, USBCheck, VariSense, VectorBlox, VeriPHY, ViewSpan, WiperLock, XpressConnect, and ZENA are trademarks of Microchip Technology Incorporated in the U.S.A. and other countries.

SQTP is a service mark of Microchip Technology Incorporated in the U.S.A.

The Adaptec logo, Frequency on Demand, Silicon Storage Technology, and Symmcom are registered trademarks of Microchip Technology Inc. in other countries.

GestIC is a registered trademark of Microchip Technology Germany II GmbH & Co. KG, a subsidiary of Microchip Technology Inc., in other countries.

All other trademarks mentioned herein are property of their respective companies.

© 2018-2021, Microchip Technology Incorporated, All Rights Reserved.

ISBN: 978-1-5224-8848-4

For information regarding Microchip's Quality Management Systems, please visit www.microchip.com/quality.



MICROCHIP

Worldwide Sales and Service

AMERICAS

Corporate Office
2355 West Chandler Blvd.
Chandler, AZ 85224-6199
Tel: 480-792-7200
Fax: 480-792-7277
Technical Support:
<http://www.microchip.com/support>
Web Address:
www.microchip.com

Atlanta

Duluth, GA
Tel: 678-957-9614
Fax: 678-957-1455

Austin, TX

Tel: 512-257-3370

Boston

Westborough, MA
Tel: 774-760-0087
Fax: 774-760-0088

Chicago

Itasca, IL
Tel: 630-285-0071
Fax: 630-285-0075

Dallas

Addison, TX
Tel: 972-818-7423
Fax: 972-818-2924

Detroit

Novi, MI
Tel: 248-848-4000

Houston, TX

Tel: 281-894-5983

Indianapolis

Noblesville, IN
Tel: 317-773-8323
Fax: 317-773-5453
Tel: 317-536-2380

Los Angeles

Mission Viejo, CA
Tel: 949-462-9523
Fax: 949-462-9608
Tel: 951-273-7800

Raleigh, NC

Tel: 919-844-7510

New York, NY

Tel: 631-435-6000

San Jose, CA

Tel: 408-735-9110
Tel: 408-436-4270

Canada - Toronto

Tel: 905-695-1980
Fax: 905-695-2078

ASIA/PACIFIC

Australia - Sydney
Tel: 61-2-9868-6733

China - Beijing
Tel: 86-10-8569-7000

China - Chengdu
Tel: 86-28-8665-5511

China - Chongqing
Tel: 86-23-8980-9588

China - Dongguan
Tel: 86-769-8702-9880

China - Guangzhou
Tel: 86-20-8755-8029

China - Hangzhou
Tel: 86-571-8792-8115

China - Hong Kong SAR
Tel: 852-2943-5100

China - Nanjing
Tel: 86-25-8473-2460

China - Qingdao
Tel: 86-532-8502-7355

China - Shanghai
Tel: 86-21-3326-8000

China - Shenyang
Tel: 86-24-2334-2829

China - Shenzhen
Tel: 86-755-8864-2200

China - Suzhou
Tel: 86-186-6233-1526

China - Wuhan
Tel: 86-27-5980-5300

China - Xian
Tel: 86-29-8833-7252

China - Xiamen
Tel: 86-592-2388138

China - Zhuhai
Tel: 86-756-3210040

ASIA/PACIFIC

India - Bangalore
Tel: 91-80-3090-4444

India - New Delhi
Tel: 91-11-4160-8631

India - Pune
Tel: 91-20-4121-0141

Japan - Osaka
Tel: 81-6-6152-7160

Japan - Tokyo
Tel: 81-3-6880-3770

Korea - Daegu
Tel: 82-53-744-4301

Korea - Seoul
Tel: 82-2-554-7200

Malaysia - Kuala Lumpur
Tel: 60-3-7651-7906

Malaysia - Penang
Tel: 60-4-227-8870

Philippines - Manila
Tel: 63-2-634-9065

Singapore
Tel: 65-6334-8870

Taiwan - Hsin Chu
Tel: 886-3-577-8366

Taiwan - Kaohsiung
Tel: 886-7-213-7830

Taiwan - Taipei
Tel: 886-2-2508-8600

Thailand - Bangkok
Tel: 66-2-694-1351

Vietnam - Ho Chi Minh
Tel: 84-28-5448-2100

EUROPE

Austria - Wels
Tel: 43-7242-2244-39
Fax: 43-7242-2244-393

Denmark - Copenhagen
Tel: 45-4485-5910
Fax: 45-4485-2829

Finland - Espoo
Tel: 358-9-4520-820

France - Paris
Tel: 33-1-69-53-63-20
Fax: 33-1-69-30-90-79

Germany - Garching
Tel: 49-8931-9700

Germany - Haan
Tel: 49-2129-3766400

Germany - Heilbronn
Tel: 49-7131-72400

Germany - Karlsruhe
Tel: 49-721-625370

Germany - Munich
Tel: 49-89-627-144-0
Fax: 49-89-627-144-44

Germany - Rosenheim
Tel: 49-8031-354-560

Israel - Ra'anana
Tel: 972-9-744-7705

Italy - Milan
Tel: 39-0331-742611
Fax: 39-0331-466781

Italy - Padova
Tel: 39-049-7625286

Netherlands - Drunen
Tel: 31-416-690399
Fax: 31-416-690340

Norway - Trondheim
Tel: 47-7288-4388

Poland - Warsaw
Tel: 48-22-3325737

Romania - Bucharest
Tel: 40-21-407-87-50

Spain - Madrid
Tel: 34-91-708-08-90
Fax: 34-91-708-08-91

Sweden - Gothenberg
Tel: 46-31-704-60-40

Sweden - Stockholm
Tel: 46-8-5090-4654

UK - Wokingham
Tel: 44-118-921-5800
Fax: 44-118-921-5820