



## Product Change Notification / SYST-28PQGR961

---

### Date:

29-Apr-2021

### Product Category:

Bluetooth Module

### PCN Type:

Document Change

### Notification Subject:

Data Sheet - BM62 / BM64 Datasheet Document Revision

### Affected CPNs:

[SYST-28PQGR961\\_Affected\\_CPN\\_04292021.pdf](#)

[SYST-28PQGR961\\_Affected\\_CPN\\_04292021.csv](#)

### Notification Text:

SYST-28PQGR961

Microchip has released a new Product Documents for the BM62 / BM64 Datasheet of devices. If you are using one of these devices please read the document located at [BM62 / BM64 Datasheet](#).

**Notification Status:** Final

### Description of Change:

This revision includes the following changes, which were incorporated throughout the document.

#### MAJOR SECTION UPDATES

- 1) 1.0 "Device Overview: Updated Table 1-3 with the new terminologies. For more details, see the below note
- 2) 5.3 "I2S Mode Application" - Updated with the new terminologies. For more details, see the below note

3) 8.1 "Timing Specifications" - Updated with the new terminologies. For more details, see the below note

4) Appendix A: "Certification Notices" - Updated content, added A.1.4 "Approved Antennas", added A.2.3 "Approved Antennas", and updated A.3 "Europe"

Note 1: Microchip is aware that some terminologies used in the technical documents and existing software codes of this product are outdated and unsuitable. This document may use these new terminologies, which may or may not reflect on the source codes, software GUIs, and the documents referenced within this document. The following table shows the relevant terminology changes made in this document.

#### TERMINOLOGY RELATED CHANGES

1.0 Device Overview is updated with the new terminology

Old Terminology: Master; New Terminology: Central

Old Terminology: Slave; New Terminology: Peripheral

5.3 "I2S Mode Application" is updated with the new terminology

Old Terminology: I2S Master; New Terminology: I2S Host

Old Terminology: I2S Slave; New Terminology: I2S Client

8.1 "Timing Specifications" is updated with the new terminology

Old Terminology: I2S Master; New Terminology: I2S Host

Old Terminology: I2S Slave; New Terminology: I2S Client

**Impacts to Data Sheet:** None

**Reason for Change:** To Improve Productivity

**Change Implementation Status:** Complete

**Date Document Changes Effective:** 29 Apr 2021

**NOTE:** Please be advised that this is a change to the document only the product has not been changed.

**Markings to Distinguish Revised from Unrevised Devices:** N/A

## Attachments:

[BM62 / BM64 Datasheet](#)

Please contact your local [Microchip sales office](#) with questions or concerns regarding this notification.

## Terms and Conditions:

If you wish to receive Microchip PCNs via email please register for our PCN email service at our [PCN home page](#) select register then fill in the required fields. You will find instructions about registering for Microchips PCN email service in the [PCN FAQ](#) section.

If you wish to change your PCN profile, including opt out, please go to the [PCN home page](#) select login and sign into your myMicrochip account. Select a profile option from the left navigation bar and make the applicable selections.

## Bluetooth® Stereo Audio Module

### Features

- Qualified for Bluetooth v5.0 specification
- Supports A2DP 1.3, AVRCP 1.6, HFP 1.7.2, HSP 1.2 and SPP 1.2
- Supports Bluetooth 5.0 dual-mode (BDR/EDR/ BLE) specifications
- Stand-alone module with on-board PCB antenna and Bluetooth stack
- Supports high resolution up to 24-bit, 96 kHz audio data format
- Supports Bluetooth Low Energy data rate up to 1Mbits/s
- Supports connection of two hosts with HFP/A2DP profiles simultaneously
- Transparent UART mode for seamless serial data over UART interface
- Supports virtual UART communication between host MCU and smartphone applications by Bluetooth SPP or BLE link
- Easy to configure with Windows® GUI or directly by external MCU
- Supports firmware field upgrade
- Supports one microphone
- Compact surface mount module:
  - BM62: 29 x 15 x 2.5 mm
  - BM64: 32 x 15 x 2.5 mm
- Castellated surface mount pads for easy and reliable host PCB mounting
- RoHS compliant
- Ideal for portable battery-operated devices
- Internal battery regulator circuitry

### DSP Audio Processing

- Supports 64 kbps A-Law,  $\mu$ -Law PCM format/ Continuous Variable Slope Delta (CVSD) modulation for SCO channel operation
- Supports 8/16 kHz noise suppression
- Supports 8/16 kHz echo cancellation
- Supports Modified Sub-Band Coding (MSBC) decoder for wide band speech
- Built-in High Definition Clean Audio (HCA) algorithms for both narrow band and wide band speech processing
- Packet loss concealment (PLC)
- Built-in audio effect algorithms to enhance audio streaming

- Supports Serial Copy Management System (SCMS-T) content protection

**FIGURE 1: BM62 MODULE**

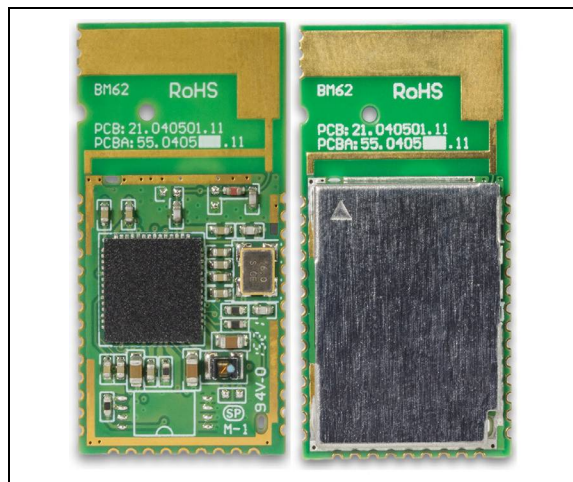

**FIGURE 2: BM64 MODULE**

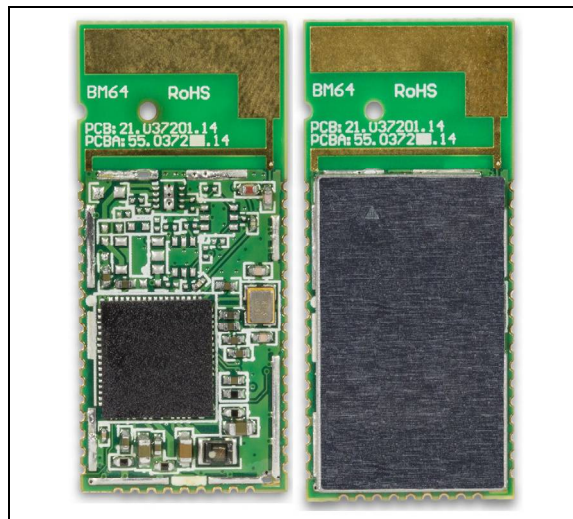

### Audio Codec

- Sub-band Coding (SBC) and optional Advanced Audio Coding (AAC) decoding
- 20-bit Digital-to-Analog Converter (DAC) with 98 dB SNR
- 16-bit Analog-to-Digital Converter (ADC) with 92 dB SNR
- Supports up to 24-bit, 96 kHz I<sup>2</sup>S digital audio (BM64 only)

# BM62/64

---

## Peripherals

- Built-in lithium-ion and lithium-polymer battery charger (up to 350 mA)
- Integrated 1.8V and 3V configurable switching regulator and Low-Dropout (LDO) regulator
- Built-in ADC for battery monitoring and voltage sense
- Built-in ADC for charger thermal protection
- Built-in Undervoltage Protection (UVP)
- An auxiliary input port for external audio input
- Two LED drivers
- Multiple I/O pins for control and status

## RF/Analog

- Frequency spectrum: 2.402 GHz to 2.480 GHz
- Receive sensitivity: -90 dBm (2 Mbps EDR)
- Output Power
  - BM64 Class 1: +15 dBm typical
  - BM62/64 Class 2: +2 dBm typical

## HCI Interface

- High-speed HCI-UART interface (supports up to 921,600 bps)

## MAC/Baseband Processor

- Supports Bluetooth 5.0 dual-mode
  - BDR/EDR transport for audio, voice, and SPP data exchange
  - BLE transport for proprietary transparent service and Apple Notification Center Service (ANCS) data exchange

## Operating Condition

- Operating voltage: 3.2V to 4.2V
- Operating temperature: -20°C to +70°C

## Compliance

- Bluetooth Special Interest Group (SIG) QDID: 110148 (BM62, BM64 Class 2) and 110159 (BM64 Class 1)
- Certified to the United States (FCC), Innovation, Science and Economic Development Canada (ISED), European Economic Area (CE), Korea (KCC), Taiwan (NCC), Japan (MIC), China (SRRC), and Brazil (ANATEL) radio regulations

## Applications

- Portable speaker
- Multiple speakers
- Headset

## Description

The BM62/64 Stereo Audio module is a fully qualified Bluetooth v5.0 dual-mode (BDR/EDR/BLE) module for designers to add wireless audio and voice applications to their products. The BM62/64 module is a Bluetooth SIG-certified module that provides a complete wireless solution with a Bluetooth stack, an integrated PCB antenna, and worldwide radio certifications in a compact surface-mount package.

The BM62/64 module has several SKUs. The BM62 module is a Class 2 device and the BM64 module is available in both Class 1 and Class 2 versions.

## Table of Contents

1.0 Device Overview .....	6
2.0 Audio .....	15
3.0 Transceiver .....	20
4.0 Power Management Unit .....	22
5.0 Application Information .....	25
6.0 Printed Antenna Information .....	43
7.0 Physical Dimensions .....	46
8.0 Electrical Characteristics .....	50
9.0 Soldering Recommendations .....	58
10.0 Ordering Information .....	59
Appendix A: Certification Notices .....	60
Appendix B: Revision History .....	70

### TO OUR VALUED CUSTOMERS

It is our intention to provide our valued customers with the best documentation possible to ensure successful use of your Microchip products. To this end, we will continue to improve our publications to better suit your needs. Our publications will be refined and enhanced as new volumes and updates are introduced.

If you have any questions or comments regarding this publication, please contact the Marketing Communications Department via E-mail at [docerrors@microchip.com](mailto:docerrors@microchip.com) or fax the **Reader Response Form** in the back of this data sheet to (480) 792-4150. We welcome your feedback.

#### Most Current Data Sheet

To obtain the most up-to-date version of this data sheet, please register at our Worldwide Web site at:

<http://www.microchip.com>

You can determine the version of a data sheet by examining its literature number found on the bottom outside corner of any page. The last character of the literature number is the version number, (e.g., DS30000000A is version A of document DS30000000).

#### Errata

An errata sheet, describing minor operational differences from the data sheet and recommended workarounds, may exist for current devices. As device/documentation issues become known to us, we will publish an errata sheet. The errata will specify the revision of silicon and revision of document to which it applies.

To determine if an errata sheet exists for a particular device, please check with one of the following:

- Microchip's Worldwide Web site; <http://www.microchip.com>
- Your local Microchip sales office (see last page)

When contacting a sales office, please specify which device, revision of silicon and data sheet (include literature number) you are using.

#### Customer Notification System

Register on our web site at [www.microchip.com](http://www.microchip.com) to receive the most current information on all of our products.

# BM62/64

## 1.0 DEVICE OVERVIEW

The BM62 and BM64 Stereo Audio modules are built around Microchip Technology IS2062 and IS2064 SoCs.

The IS2062/64 SoC integrates the Bluetooth 5.0 dual-mode radio transceiver, Power Management Unit (PMU), a crystal and DSP. Users can configure the BM62/64 module by using the UI tool and DSP tool, a

Windows-based utility.

**Note:** The UI and DSP tools are available for download from the Microchip website at: [www.microchip.com/BM62](http://www.microchip.com/BM62) and [www.microchip.com/BM64](http://www.microchip.com/BM64).

Figure 1-1 illustrates a typical example of the BM62 module, which is connected to an external audio amplifier and the MCU.

**FIGURE 1-1: SINGLE SPEAKER APPLICATION USING BM62 MODULE**

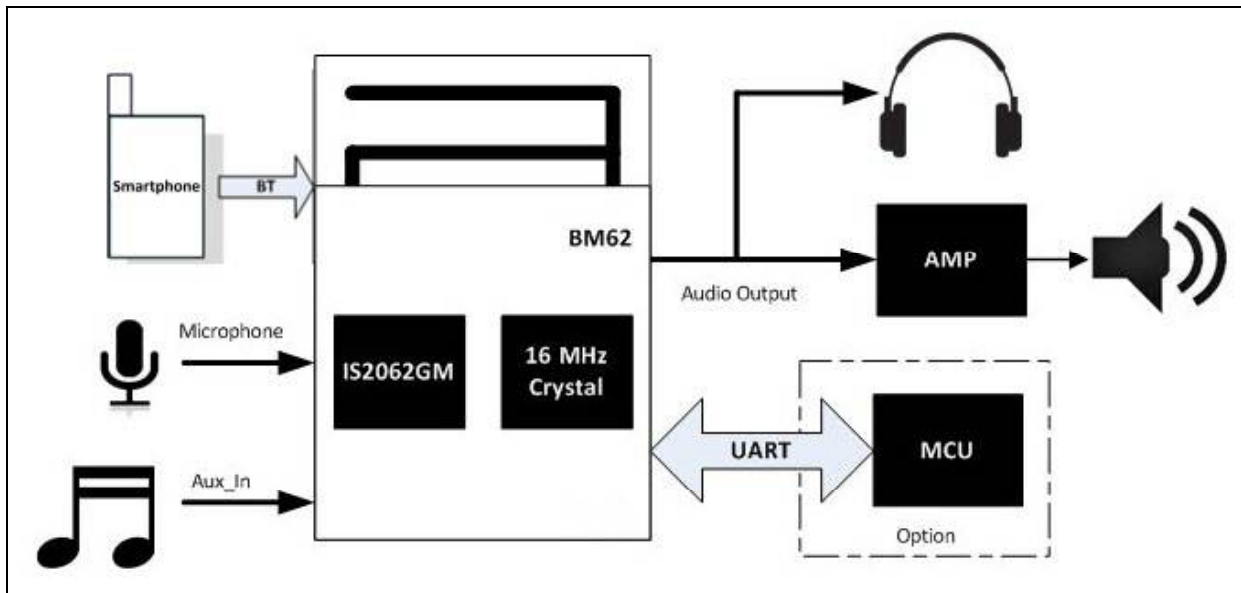

Figure 1-2 illustrates a typical example of the Class 1 BM64 module, which is connected to an external MCU and a DSP/codec.

**FIGURE 1-2: SINGLE SPEAKER APPLICATION USING BM64 MODULE**

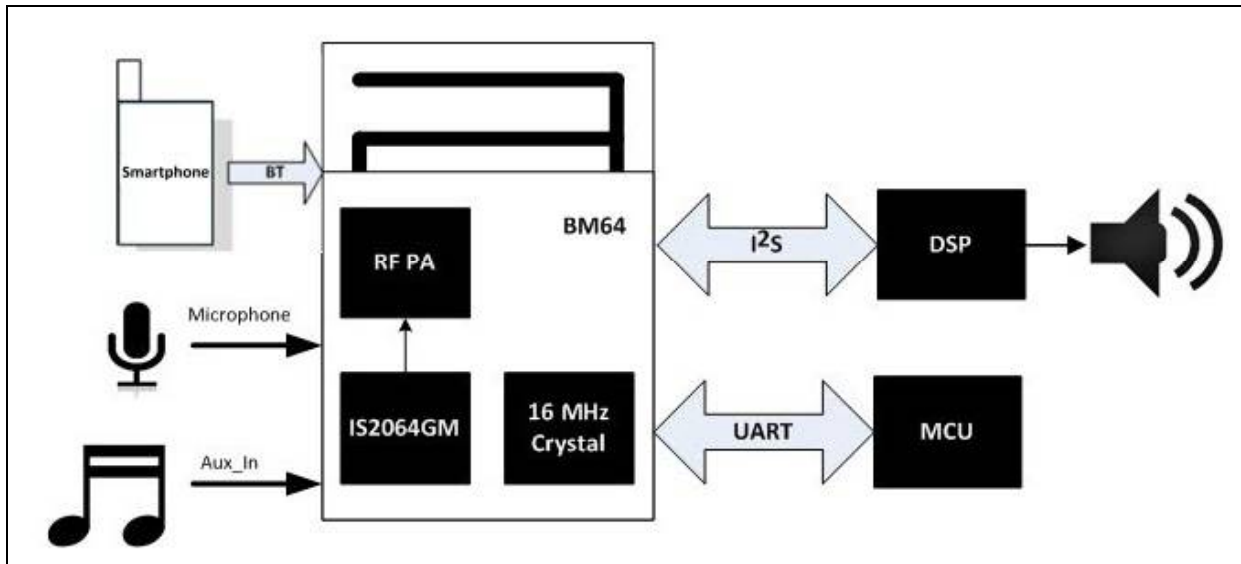
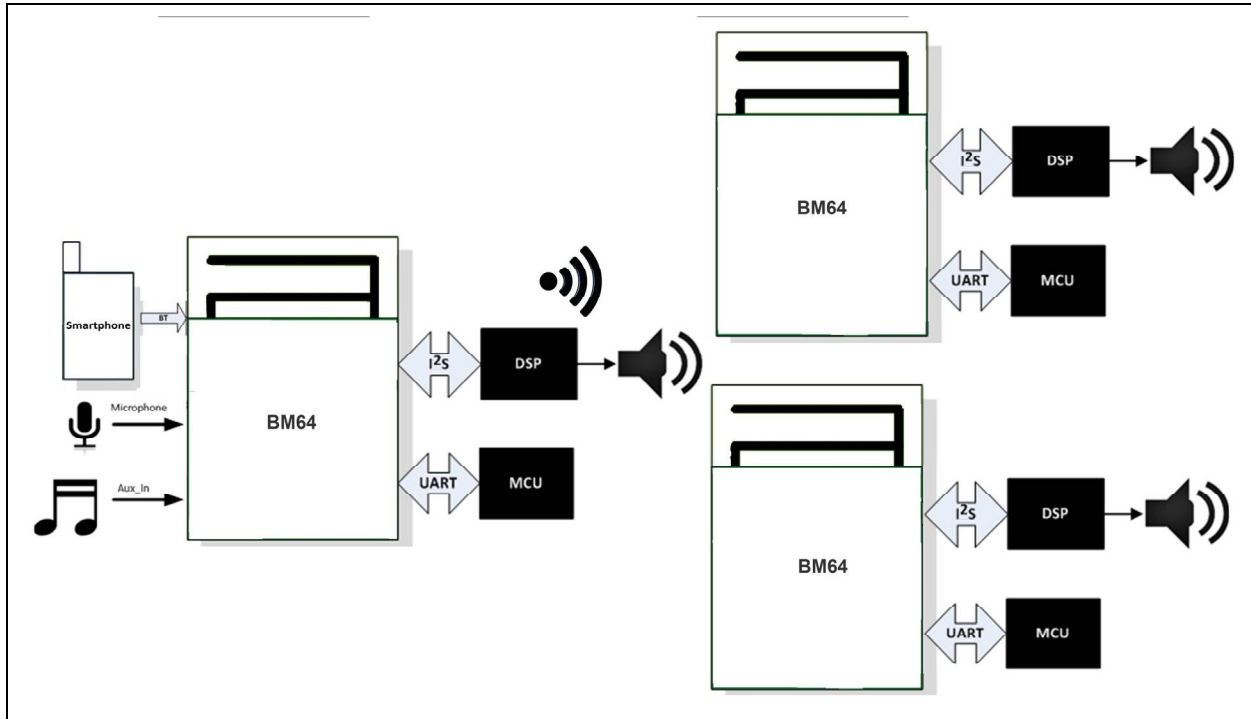

Figure 1-3 illustrates the multi-speaker application using the BM64 module.

**FIGURE 1-3: MULTI-SPEAKER APPLICATION USING BM64 MODULE**





# BM62/64

Table 1-1 provides the key features of the BM62/64 module.

**TABLE 1-1: BM62/64 KEY FEATURES**

Feature	BM62 CLASS 2	BM64 CLASS 2	BM64 CLASS 1
Application	Headset/Speaker	Multi-Speaker/Soundbar	
Stereo/mono	Stereo	Stereo	Stereo
Pin count	37	43	43
Dimensions (mm <sup>2</sup> )	15 x 29	15 x 32	15 x 32
PCB antenna	Yes	Yes	Yes
Tx power (typical)	2 dBm	2 dBm	15 dBm
Audio DAC output	2-channel	2-channel	2-channel
DAC (single-ended) SNR at 2.8V (dB)	-98	-98	-98
DAC (capless) SNR at 2.8V (dB)	-98	-98	-98
ADC SNR at 2.8V (dB)	-92	-92	-92
I <sup>2</sup> S digital output	No	Yes	Yes
Analog Auxiliary-Input	Yes	Yes	Yes
Mono microphone	1	1	1
External audio amplifier interface	Yes	Yes	Yes
UART	Yes	Yes	Yes
Full-speed USB 1.1	No	Yes	Yes
LED driver	2	2	2
Internal DC-DC step down regulator	Yes	Yes	Yes
DC 5V adapter input	Yes	Yes	Yes
Battery charger (350 mA max)	Yes	Yes	Yes
ADC for thermal charger protection	Yes	Yes	Yes
Under voltage protection (UVP)	Yes	Yes	Yes
GPIO	10	12	12
Button support	6	6	6
EEPROM	Yes	Yes	Yes
Customized voice prompt	8K Sampling Rate, Stored in EEPROM with approximately 800 bytes/second		
Multitone	Yes	Yes	Yes
DSP functions (audio playback and voice call)	Yes	Yes	Yes
BLE	Yes	Yes	Yes
<b>Bluetooth profiles</b>			
A2DP	1.3	1.3	1.3
AVRCP	1.6	1.6	1.6
HFP	1.7.2	1.7.2	1.7.2
HSP	1.2	1.2	1.2
SPP	1.2	1.2	1.2

Figure 1-4 illustrates the pin diagram of the BM62 module.

**FIGURE 1-4: BM62 MODULE PIN DIAGRAM**

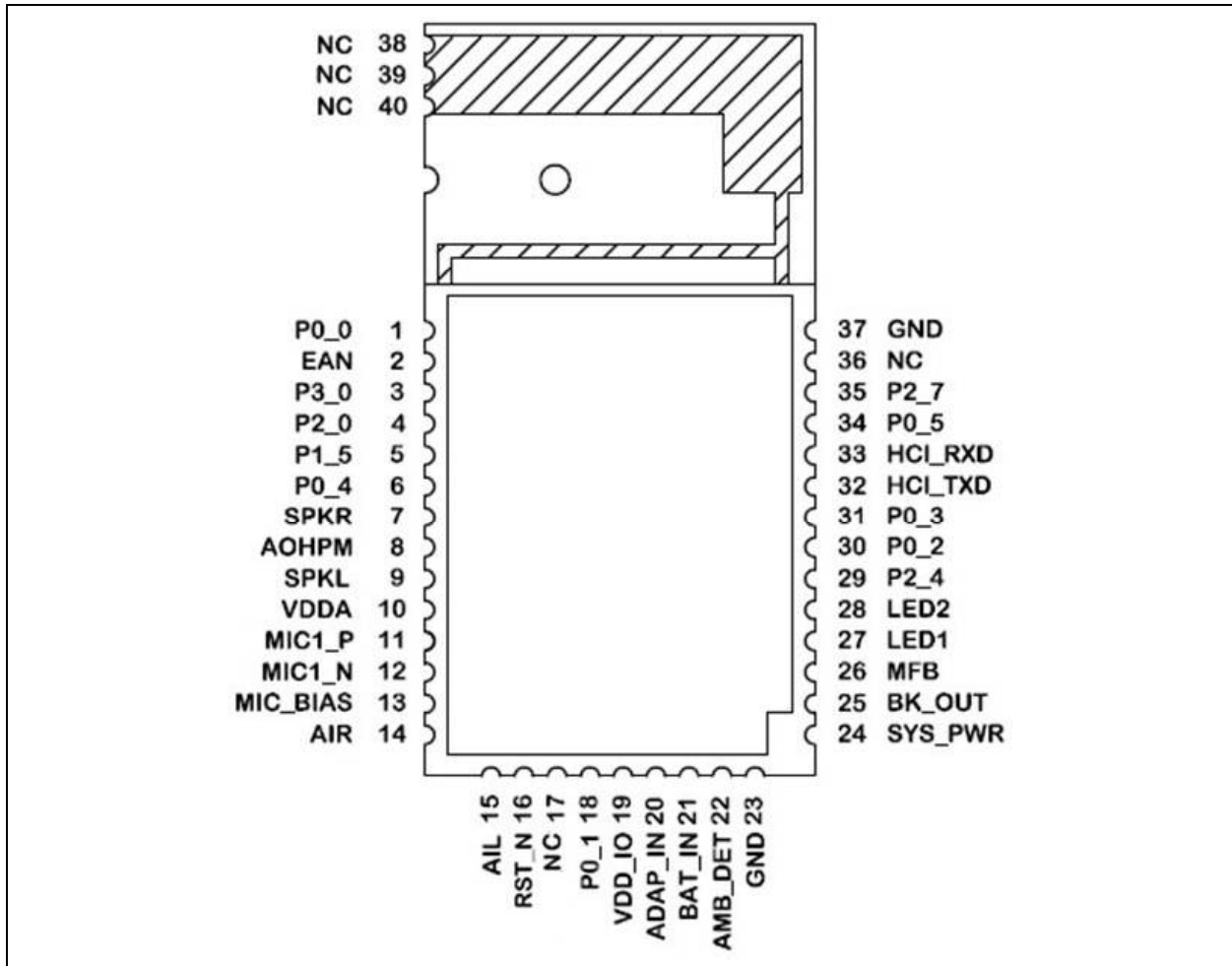

# BM62/64

Table 1-2 provides the pin description of the BM62 module.

**TABLE 1-2: BM62 MODULE PIN DESCRIPTION**

Pin No	Pin Type	Pin Name	Description
1	I/O	P0_0	Configurable control or indication pin (Internally pulled up, if configured as an input) <ul style="list-style-type: none"> <li>Slide switch detector, active-high</li> <li>UART TX_IND, active-low (used by Bluetooth system to wakeup the host MCU)</li> </ul>
2	I	EAN	External address bus negative System configuration pin along with the P2_0 and P2_4 pins, used to set the module in any one of the following three modes: <ul style="list-style-type: none"> <li>Application mode (for normal operation)</li> <li>Test mode (to change EEPROM values)</li> <li>Write Flash mode (to load a new firmware into the module), refer to Table 5-1</li> </ul> Flash type module already installed internal pull down resistor 4.7 kOhm to GND
3	I/O	P3_0	Configurable control or indication pin (Internally pulled up, if configured as an input) Auxiliary input detector, active-low
4	I/O	P2_0	System configuration pin along with P2_4 and EAN pins used to set the module in any one of the following three modes: <ul style="list-style-type: none"> <li>Application mode (for normal operation)</li> <li>Test mode (to change EEPROM values)</li> <li>Write Flash mode (to load a new firmware into the module), refer to Table 5-1</li> </ul>
5	I/O	P1_5	Configurable control or indication pin (Internally pulled up, if configured as an input) <ul style="list-style-type: none"> <li>NFC detection pin, active-low</li> <li>Out_Ind_1</li> <li>Slide switch detector, active-high</li> </ul>
6	I/O	P0_4	Configurable control or indication pin (Internally pulled up, if configured as an input) <ul style="list-style-type: none"> <li>NFC detection pin, active-low</li> <li>Out_Ind_1</li> </ul>
7	O	SPKR	Right-channel, analog headphone output
8	O	AOHPM	Headphone common mode output/sense input
9	O	SPKL	Left-channel, analog headphone output
10	P	VDDA	Analog reference voltage. Do not connect, for internal use only
11	I	MIC1_P	MIC1 mono differential analog positive input
12	I	MIC1_N	MIC1 mono differential analog negative input
13	P	MIC1_BIAS	Electric microphone biasing voltage
14	I	AIR	Right-channel, single-ended analog input
15	I	AIL	Left-channel, single-ended analog input

**Legend:** I= Input pin O= Output pin I/O= Input/Output pin P= Power pin

**Note:** All I/O pins can be configured using the UI tool, a Windows utility.

**TABLE 1-2: BM62 MODULE PIN DESCRIPTION (CONTINUED)**

Pin No	Pin Type	Pin Name	Description
16	I	RST_N	System Reset (active-low)
17	-	NC	No connection
18	I/O	P0_1	Configurable control or indication pin (Internally pulled up, if configured as an input) <ul style="list-style-type: none"> <li>FWD key when Class 2 RF (default), active-low</li> <li>Class 1 Tx control signal for external RF Tx/Rx switch, active-high</li> </ul>
19	P	VDD_IO	I/O positive supply. Do not connect, for internal use only
20	P	ADAP_IN	5V power adapter input, used to charge the battery in the Li-Ion battery power applications
21	P	BAT_IN	Power Supply input. Voltage range: 3.2V to 4.2V. Source can either be a Li-Ion battery or any other power rail on the host board
22	P	AMB_DET	Analog input for ambient temperature detection
23	P	GND	Ground reference
24	P	SYS_PWR	System power output derived from ADAP_IN or BAT_IN. Refer to reference schematic for external connection.
25	P	BK_OUT	1.8V buck regulator output. Do not connect to other devices. For internal use only
26	I	MFB	<ul style="list-style-type: none"> <li>Multi-Function Button and power-on key</li> <li>UART RX_IND, active-high (used by host MCU to wakeup the Bluetooth system)</li> </ul>
27	O	LED1	LED driver 1
28	O	LED2	LED driver 2
29	I/O	P2_4	System configuration pin along with P2_0 and EAN pins used to set the module in any one of the following three modes: <ul style="list-style-type: none"> <li>Application mode (for normal operation)</li> <li>Test mode (to change EEPROM values)</li> <li>Write Flash mode (to load a new firmware into the module), refer to <a href="#">Table 5-1</a></li> </ul>
30	I/O	P0_2	Configurable control or indication pin (Internally pulled up, if configured as an input) Play/Pause key (default), active-low
31	I/O	P0_3	Configurable control or indication pin (Internally pulled up, if configured as an input) <ul style="list-style-type: none"> <li>REV key (default), active-low</li> <li>Buzzer signal output</li> <li>Out_Ind_2</li> <li>Class 1 Rx Control signal of external RF Tx/Rx switch, active-high</li> </ul>
32	I/O	HCI_TXD	HCI UART data output
33	I/O	HCI_RXD	HCI UART data input

**Legend:** I= Input pin      O= Output pin      I/O= Input/Output pin      P= Power pin

**Note:** All I/O pins can be configured using the UI tool, a Windows utility.

# BM62/64

**TABLE 1-2: BM62 MODULE PIN DESCRIPTION (CONTINUED)**

Pin No	Pin Type	Pin Name	Description
34	I/O	P0_5	Configurable control or indication pin (Internally pulled up, if configured as an input) Volume-down key (default), active-low
35	I/O	P2_7	Configurable control or indication pin (Internally pulled up, if configured as an input) Volume-up key (default), active-low
36	-	NC	No connection
37	P	GND	Ground reference
38	-	NC	No connection
39	-	NC	No connection
40	-	NC	No connection

**Legend:** I= Input pin      O= Output pin      I/O= Input/Output pin      P= Power pin

**Note:** All I/O pins can be configured using the UI tool, a Windows utility.

Figure 1-5 illustrates the pin diagram of the BM64 module.

**FIGURE 1-5: BM64 MODULE PIN DIAGRAM**

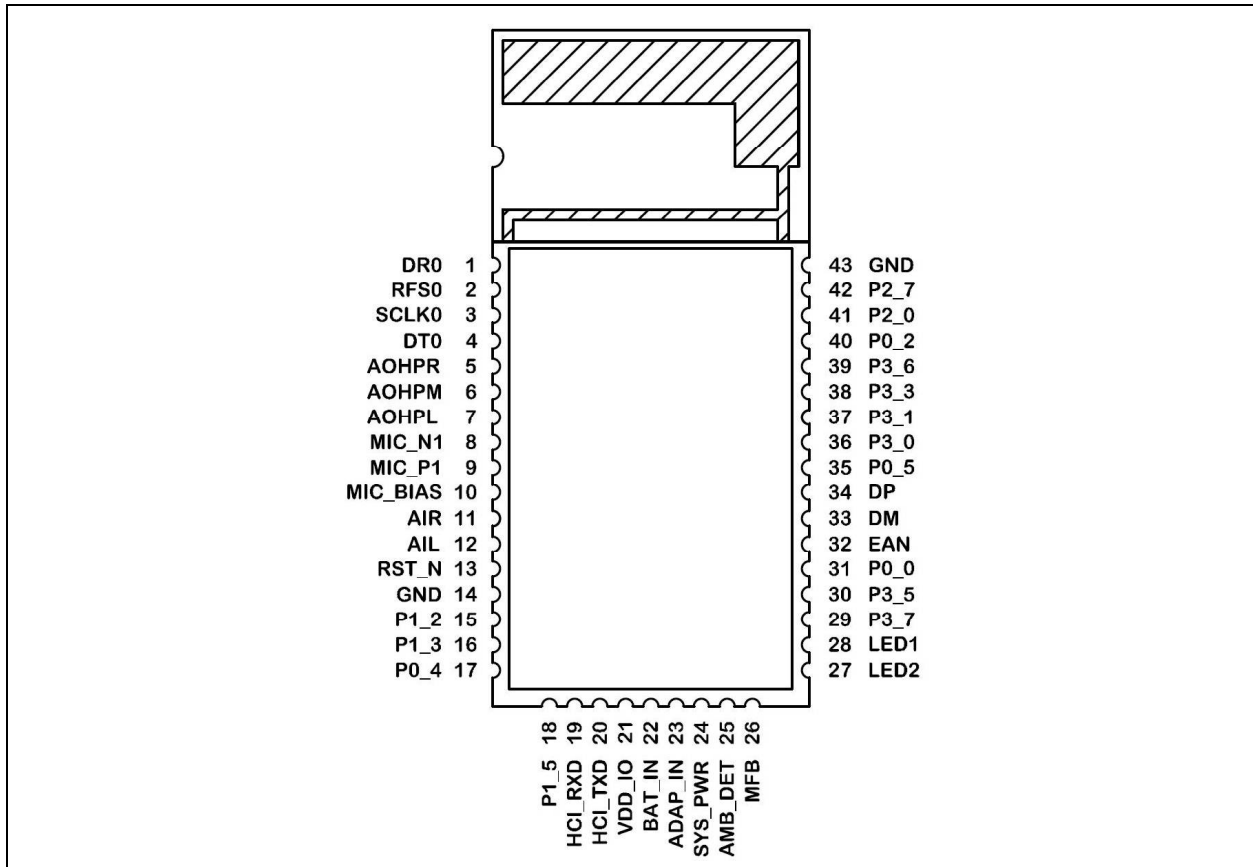

# BM62/64

Table 1-3 provides the pin description of the BM64 Module.

**TABLE 1-3: BM64 MODULE PIN DESCRIPTION**

Pin No	Pin Type	Pin Name	Description
1	I/O	DR0	I <sup>2</sup> S interface: digital left/right data
2	I/O	RFS0	I <sup>2</sup> S interface: left/right clock
3	I/O	SCLK0	I <sup>2</sup> S interface: bit clock
4	I/O	DT0	I <sup>2</sup> S interface: digital left/right data
5	O	AOHPR	Right-channel, analog headphone output
6	O	AOHPM	Headphone common mode output/sense input
7	O	AOHPL	Left-channel, analog headphone output
8	I	MIC_N1	MIC1 mono differential analog negative input
9	I	MIC_P1	MIC1 mono differential analog positive input
10	P	MIC_BIAS	Electric microphone biasing voltage
11	I	AIR	Right-channel, single-ended analog input
12	I	AIL	Left-channel, single-ended analog input
13	I	RST_N	System Reset (active-low)
14	P	GND	Ground reference
15	I/O	P1_2	EEPROM clock SCL
16	I/O	P1_3	EEPROM data SDA
17	I/O	P0_4	Configurable control or indication pin (Internally pulled up, if configured as an input) <ul style="list-style-type: none"> <li>NFC detection pin, active-low</li> <li>Out_Ind_1</li> </ul>
18	I/O	P1_5	Configurable control or indication pin (Internally pulled up, if configured as an input) <ul style="list-style-type: none"> <li>NFC detection pin, active-low</li> <li>Slide switch detector, active-high</li> <li>Out_Ind_1</li> <li>Multi-SPK Central/Peripheral mode control (firmware dependent)</li> </ul>
19	I	HCI_RXD	HCI-UART data input
20	O	HCI_TXD	HCI-UART data output
21	P	VDD_IO	I/O positive supply. Do not connect, for internal use only
22	P	BAT_IN	Power Supply input. Voltage range: 3.2V to 4.2V. Source can either be a Li-Ion battery or any other power rail on the host board
23	P	ADAP_IN	5V power adapter input, used to charge the battery in the Li-Ion battery power applications
24	P	SYS_PWR	System power output derived from ADAP_IN or BAT_IN. Refer to reference schematic for external connection.
25	P	AMB_DET	Analog input for ambient temperature detection
26	I	MFB	<ul style="list-style-type: none"> <li>Multi-Function Button and power-on key</li> <li>UART RX_IND, active-high (used by host MCU to wakeup the Bluetooth system)</li> </ul>
27	O	LED2	LED driver 2
28	O	LED1	LED driver 1

**Legend:** I= Input pin      O= Output pin      I/O= Input/Output pin      P= Power pin

**Note:** All I/O pins can be configured using the UI tool, a Windows utility.

**TABLE 1-3: BM64 MODULE PIN DESCRIPTION (CONTINUED)**

Pin No	Pin Type	Pin Name	Description
29	I/O	P3_7	Configurable control or indication pin (Internally pulled up, if configured as an input) UART TX_IND, active-low (used by Bluetooth system to wakeup the host MCU)
30	I/O	P3_5	Configurable control or indication pin (Internally pulled low, if configured as an input) • Slide switch detector, active-high
31	I/O	P0_0	Configurable control or indication pin (Internally pulled up, if configured as an input) • Slide switch detector, active-high, Out_Ind_0
32	I	EAN	External address bus negative System configuration pin along with the P2_0 pins used to set the module in any one of these modes: • Application mode (for normal operation) • Test mode (to change FW and EEPROM values) • Mode setting, refer to <a href="#">Table 5-1</a> Flash type module already installed internal pull down resistor 4.7 kOhm to GND
33	I/O	DM	Differential data-minus USB
34	I/O	DP	Differential data-plus USB
35	I/O	P0_5	Configurable control or indication pin (Internally pulled up, if configured as an input) Volume-down key (default), active-low
36	I/O	P3_0	Configurable control or indication pin (Internally pulled up, if configured as an input) Auxiliary input detector, active-low
37	I/O	P3_1	Configurable control or indication pin (Internally pulled up, if configured as an input) REV key (default), active-low
38	I/O	P3_3	Configurable control or indication pin (Internally pulled up, if configured as an input) FWD key (default), active-low
39	I/O	P3_6	Configurable control or indication pin (Internally pulled up, if configured as an input) Multi-SPK Central/Peripheral mode control (firmware dependent)
40	I/O	P0_2	Configurable control or indication pin (Internally pulled up, if configured as an input) Play/Pause key (default)
41	I/O	P2_0	System configuration pin along with EAN pins used to set the module in any one of the following modes: • Application mode (for normal operation) • Test mode (to change FW and EEPROM values) • Mode setting, refer to <a href="#">Table 5-1</a>
42	I/O	P2_7	Configurable control or indication pin (Internally pulled up, if configured as an input) Volume-up key (default), active-low
43	P	GND	Ground reference

**Legend:** I= Input pin      O= Output pin      I/O= Input/Output pin      P= Power pin

**Note:** All I/O pins can be configured using the UI tool, a Windows utility.



# BM62/64

---

---

NOTES:

## 2.0 AUDIO

The input and output audios have different stages and each stage can be programmed to vary the gain response characteristics. For microphone, both single-ended inputs and differential inputs are supported. To maintain a high quality signal, a stable bias voltage source to the condenser microphone's FET is provided. The DC blocking capacitors can be used at both positive and negative sides of an input. Internally, this analog signal is converted to 16-bit, 8/16 kHz linear PCM data.

### 2.1 Digital Signal Processor

A Digital Signal Processor (DSP) is used to perform speech and audio processing. The advanced speech features, such as acoustic echo cancellation and noise reduction are inbuilt. To reduce nonlinear distortion and to help echo cancellation, an outgoing signal level to

the speaker is monitored and adjusted to avoid saturation of speaker output or microphone input. Adaptive filtering is also applied to track the echo path impulse in response to provide echo free and full-duplex user experience.

The embedded noise reduction algorithm helps to extract clean speech signals from the noisy inputs captured by the microphones and improves mutual understanding in communication.

The advanced audio features, such as multi-band dynamic range control, parametric multi-band equalizer, audio widening and virtual bass are inbuilt. The audio effect algorithms improve the user's audio listening experience in terms of better audio quality after audio signal processing.

Figure 2-1 and Figure 2-2 illustrate the processing flow of speakerphone applications for speech and audio signal processing.

**FIGURE 2-1: SPEECH SIGNAL PROCESSING**

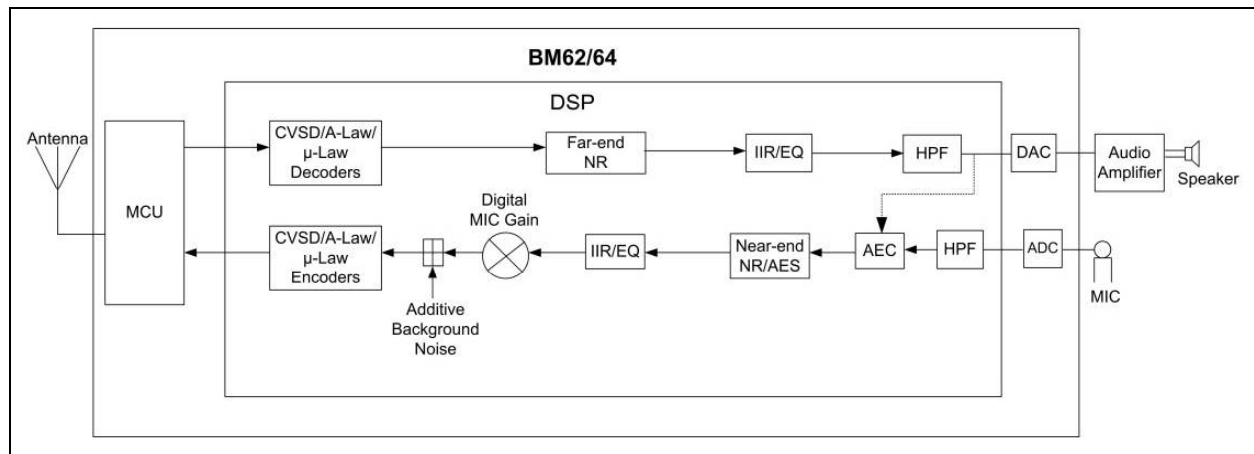

**FIGURE 2-2: AUDIO SIGNAL PROCESSING**

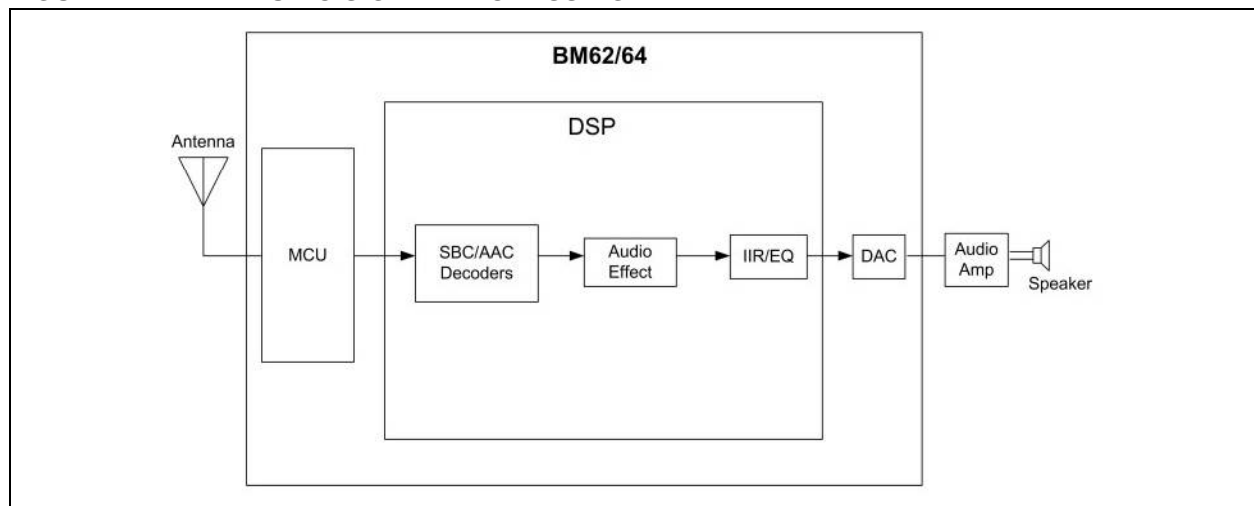

# BM62/64

The DSP parameters can be configured using the DSP tool. For additional information on the DSP tool, refer to the "IS206X DSP Application Note".

**Note:** The DSP tool and "IS206X DSP Application Note" document, are available for download from the Microchip website at: [www.microchip.com/BM62](http://www.microchip.com/BM62) and [www.microchip.com/BM64](http://www.microchip.com/BM64).

## 2.2 Codec

The built-in codec has a high signal-to-noise ratio (SNR) performance and it consists of an ADC, a DAC and an additional analog circuitry.

**Note:** The internal codec supports 16-bit resolution; by adding trailing zeros in LSBs 24-bit I<sup>2</sup>S port requirements can be met.

Figure 2-3 through Figure 2-6 illustrate the dynamic range and frequency response of the codec.

**FIGURE 2-3: CODEC DAC DYNAMIC RANGE**

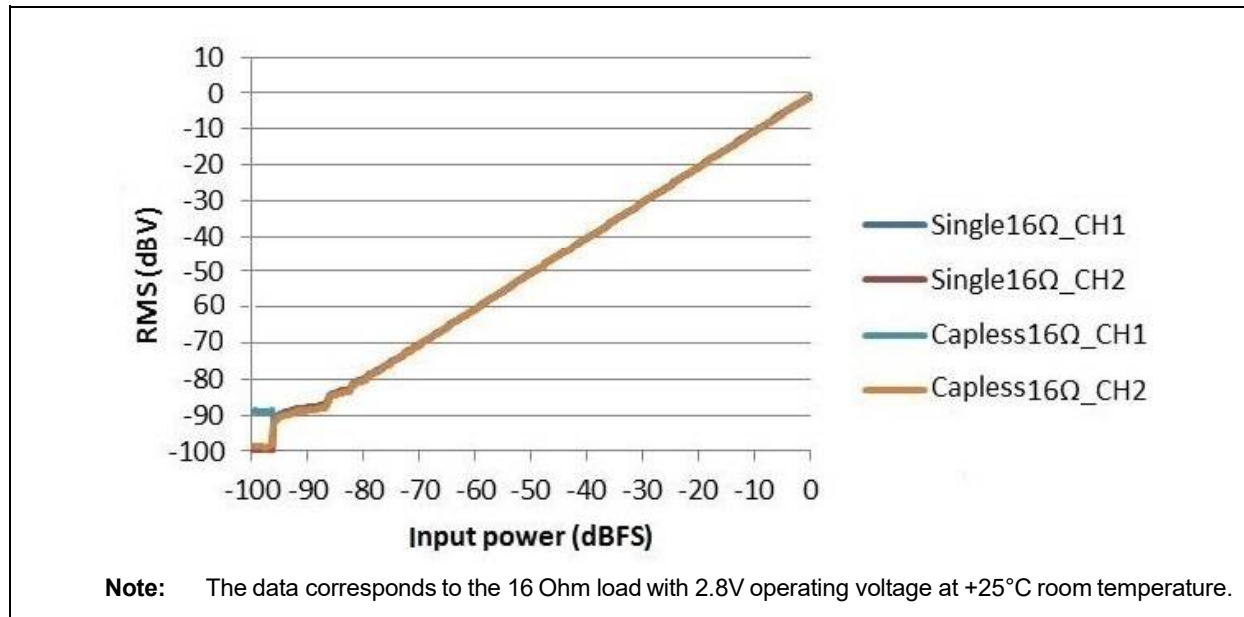

**FIGURE 2-4: CODEC DAC THD+N VERSUS INPUT POWER**

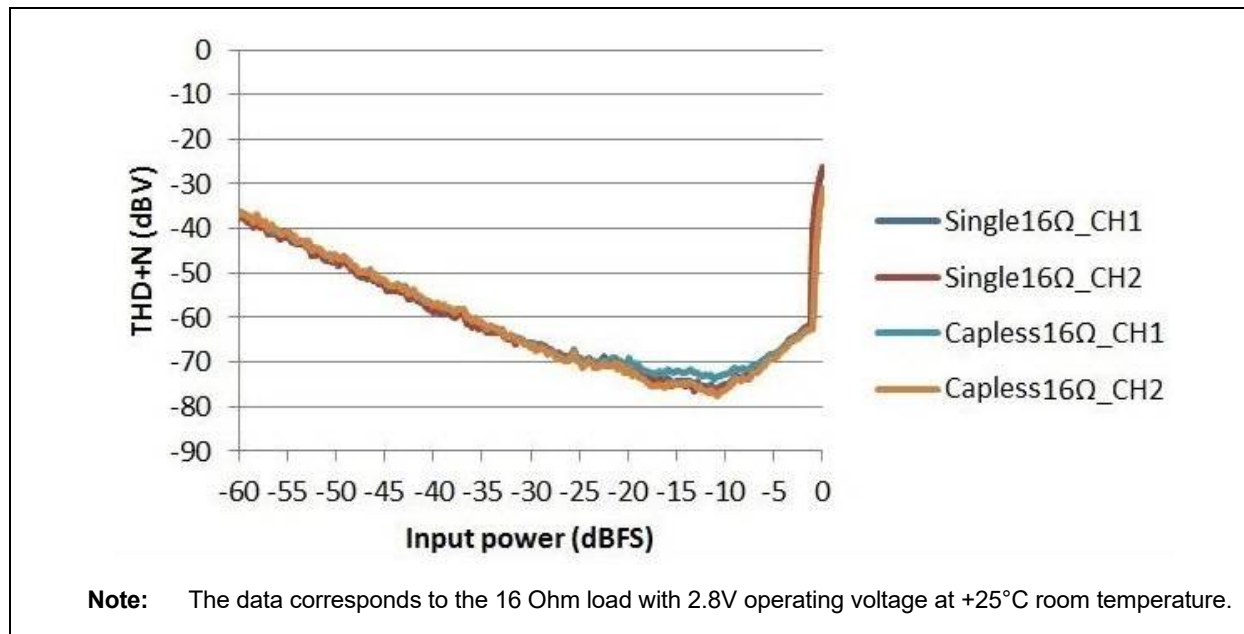

**FIGURE 2-5: CODEC DAC FREQUENCY RESPONSE (CAPLESS MODE)**

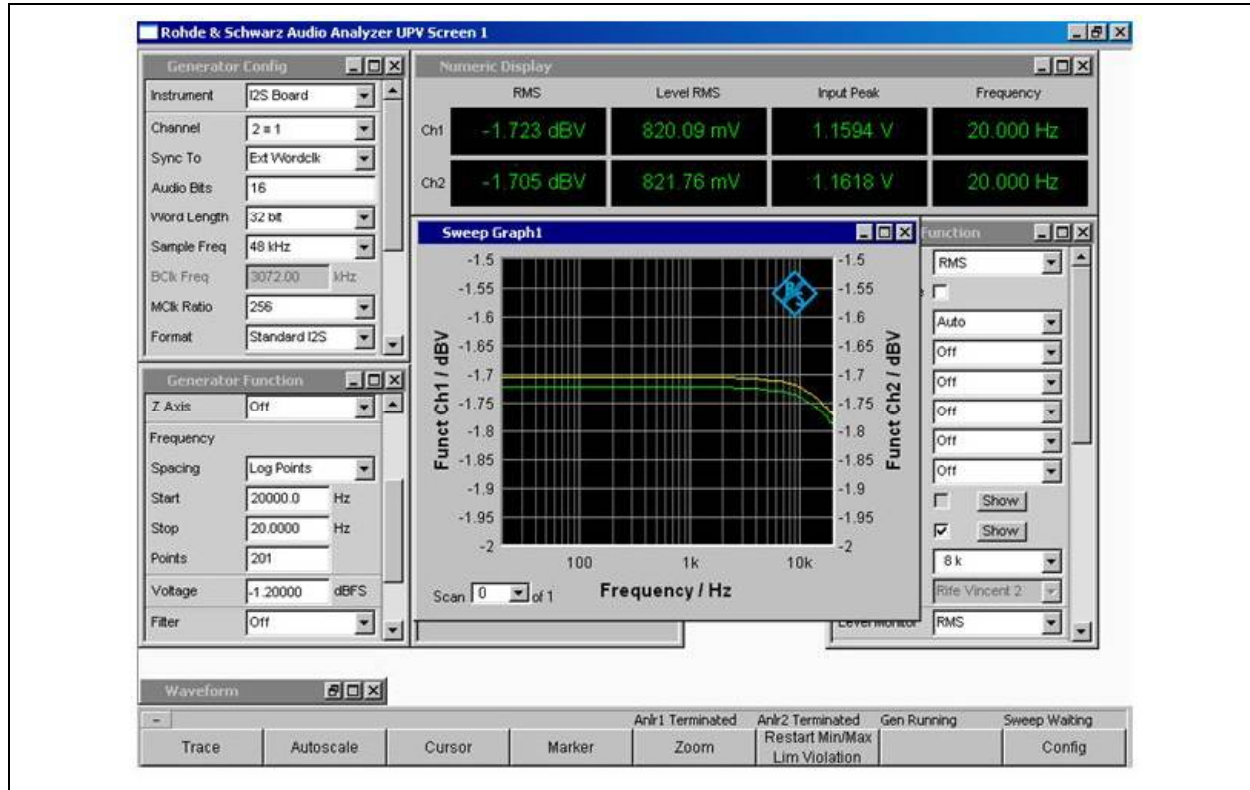

**FIGURE 2-6: CODEC DAC FREQUENCY RESPONSE (SINGLE-ENDED MODE)**

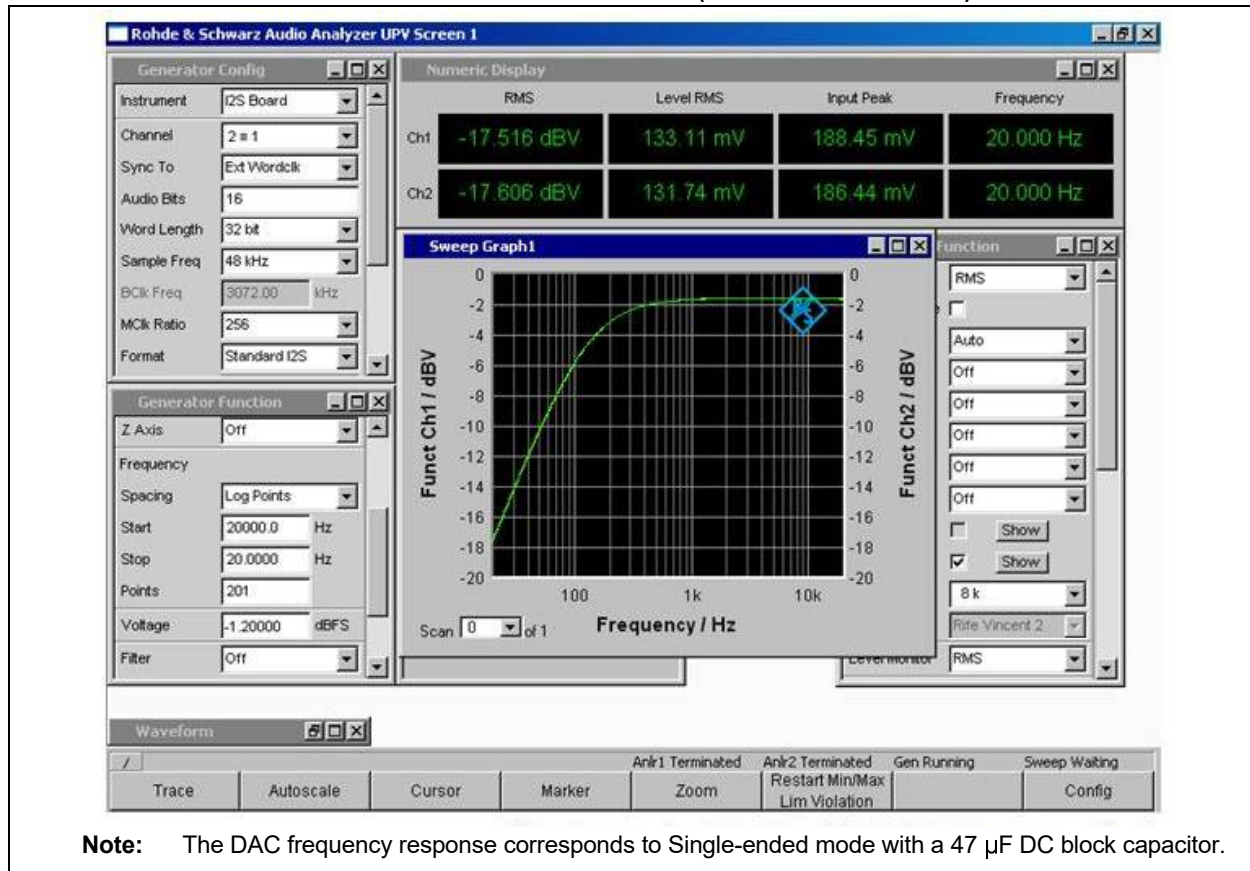

# BM62/64

## 2.3 Auxiliary Port

The BM62/64 module supports one analog (line-in) signal from the external audio source. The analog (line-in) signal can be processed by the DSP to generate different sound effects (multi-band dynamic range compression and audio widening), which can be configured by using the DSP tool.

## 2.4 Analog Speaker Output

The BM62/64 module supports the following analog speaker output modes:

- Capless mode — Recommended for headphone applications in which capless output connection helps to save the BOM cost by avoiding a large DC blocking capacitor. [Figure 2-7](#) illustrates the analog speaker output capless mode.
- Single-ended mode — Used for driving an external audio amplifier where a DC blocking capacitor is required. [Figure 2-8](#) illustrates the analog speaker output single-ended mode.

**FIGURE 2-7: ANALOG SPEAKER OUTPUT CAPLESS MODE**

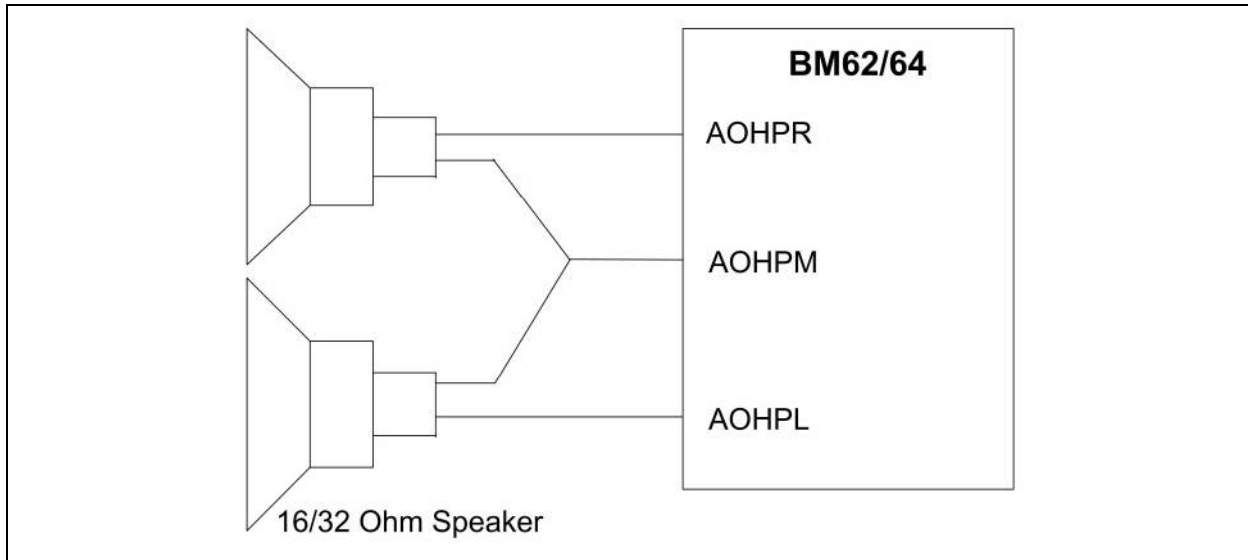

**FIGURE 2-8: ANALOG SPEAKER OUTPUT SINGLE-ENDED MODE**

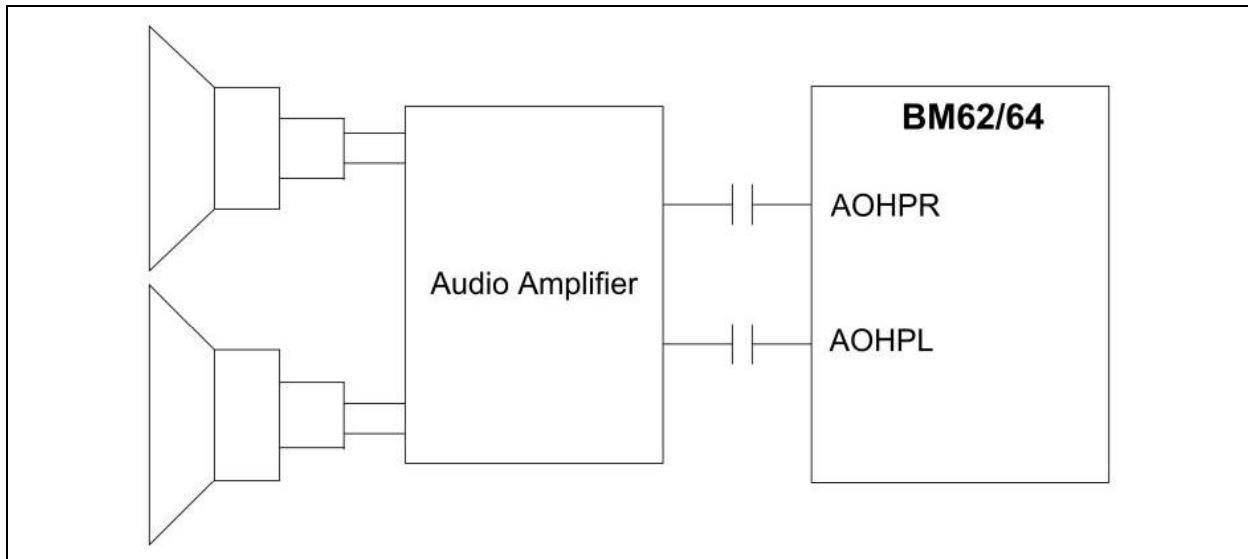

NOTES:

# BM62/64

---

---

## 3.0 TRANSCEIVER

The BM62/64 module is designed and optimized for the Bluetooth 2.4 GHz system. It contains a complete radio frequency transmitter/receiver section. An internal synthesizer generates a stable clock for synchronizing with another device.

### 3.1 Transmitter

The internal power amplifier (PA) has a maximum output power of +4 dBm. This is applied for Class 2 or Class 3 radios without an external RF PA.

The transmitter performs the IQ conversion to minimize the frequency drift.

### 3.2 Receiver

The Low-Noise Amplifier (LNA) operates with TR-combined mode for single port application. It can save a pin on the package without having an external Tx/Rx switch.

The ADC is used to sample the input analog signal and convert it into a digital signal for demodulator analysis. A channel filter has been integrated into the receiver channel before the ADC, which is used to reduce the external component count and increase the anti-interference capability.

The image rejection filter is used to reject the image frequency for low-IF architecture. This filter for low-IF architecture is intended to reduce external Band Pass Filter (BPF) component for a super heterodyne architecture.

The Received Signal Strength Indicator (RSSI) signal feedback to the processor is used to control the RF output power to make a good trade-off for effective distance and current consumption.

### 3.3 Synthesizer

A synthesizer generates a clock for radio transceiver operation. There is a VCO inside with a tunable internal LC tank that can reduce variation for components. A crystal oscillator with an internal digital trimming circuit provides a stable clock for the synthesizer.

### 3.4 Modem

For Bluetooth 1.2 specification and below, 1 Mbps was the standard data rate based on the Gaussian Frequency Shift Keying (GFSK) modulation scheme. This basic rate modem meets Basic Data Rate (BDR) requirements of Bluetooth 2.0 with Enhanced Data Rate (EDR) specifications.

For Bluetooth 2.0 and above specifications, EDR has been introduced to provide the data rates of 1/2/3 Mbps. For baseband, both BDR and EDR utilize the same 1 MHz symbol rate and 1.6 kHz slot rate. For

BDR, symbol 1 represents 1-bit. However, each symbol in the payload part of EDR packet represents 2/3 bits. This is achieved by using two different modulations,  $\pi/4$  DQPSK and 8 DPSK.

### 3.5 Adaptive Frequency Hopping (AFH)

The BM62/64 module has an AFH function to avoid RF interference. It has an algorithm to check the nearby interference and to choose clear channel for transceiver Bluetooth signal.

NOTES:



# BM62/64

## 4.0 POWER MANAGEMENT UNIT

The on-chip Power Management Unit (PMU) has two main features: lithium-ion and lithium-polymer battery charger, and voltage regulator. A power switch is used to switch over the power source between the battery and an adapter. Also, the PMU provides current to drive two LEDs.

## 4.1 Charging a Battery

The BM62/64 module has a built-in battery charger, which is optimized for lithium-ion and lithium-polymer batteries.

The battery charger includes a current sensor for charging control, user-programmable current regulation, and high accuracy voltage regulation.

The charging current parameters are configured by the UI tool. Reviving, pre-charging, constant current and constant voltage modes, and re-charging functions are included. The maximum charging current is 350 mA. [Figure 4-1](#) illustrates the charging curve of a battery.

**FIGURE 4-1: BATTERY CHARGING CURVE**

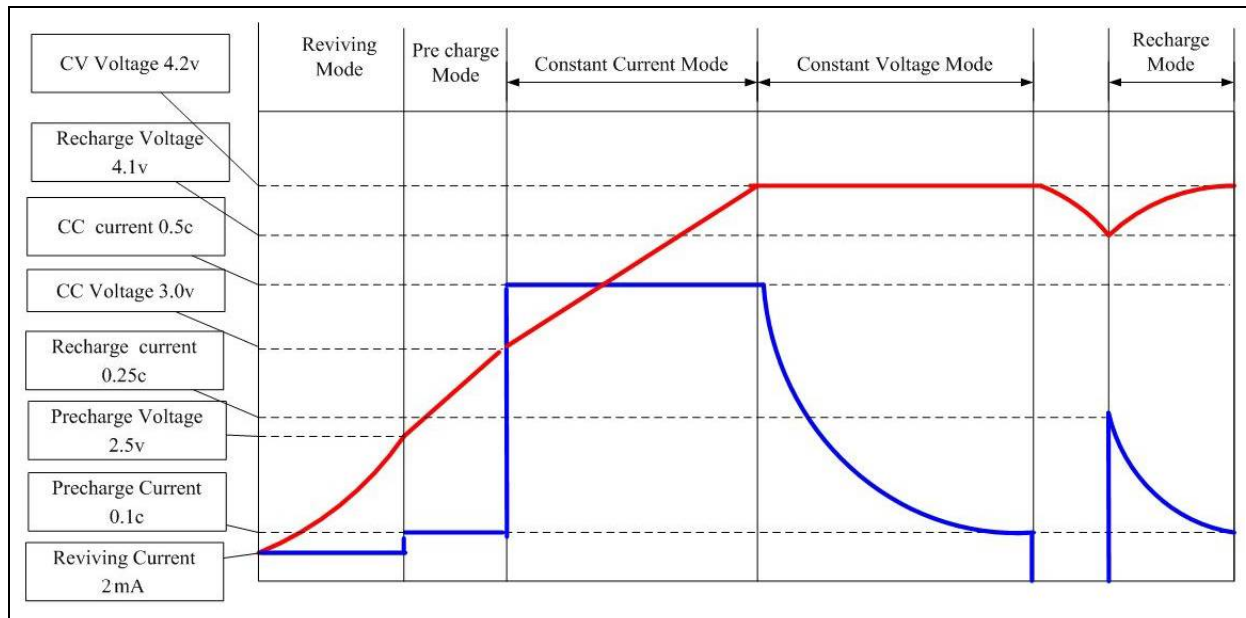

## 4.2 Voltage Monitoring

A 10-bit, successive approximation register ADC (SAR ADC) provides a dedicated channel for battery voltage level detection. The warning level can be programmed by using the UI tool. The ADC provides a granular resolution to enable the external MCU to take control over the charging process.

## 4.3 LED Drivers

Two dedicated LED drivers control the LEDs. They provide enough sink current (16 step control and 0.35 mA for each step), thus LEDs can be connected directly with the BM62/64 module. The LED settings can be configured using the UI tool.

Figure 4-2 illustrates the LED drivers in the BM62/64 module.

**FIGURE 4-2: LED DRIVERS**

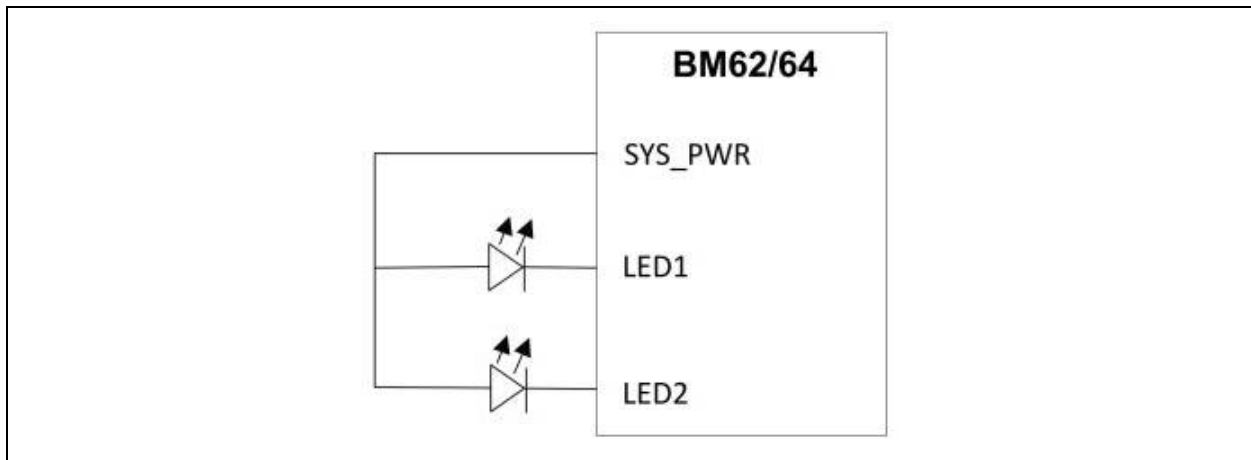

#### 4.4 Under Voltage Protection (Software Dependent UVP)

When the input voltage of the BAT\_IN is below 2.9V, the system will not be able to start up, in order to protect the system.

#### 4.5 Ambient Detection

The BM62/64 module has a built-in ADC for charger thermal protection. Figure 4-3 illustrates the suggested circuit and thermistor, Murata NCP15WF104F. The charger thermal protection can avoid battery charge in restricted temperature range. The upper and lower limits for temperature values can be configured by using the UI tool.

**Note:** Thermistor must be placed close to the battery in the user application for accurate temperature measurements and to enable the thermal shutdown feature.

# BM62/64

FIGURE 4-3: AMBIENT DETECTION

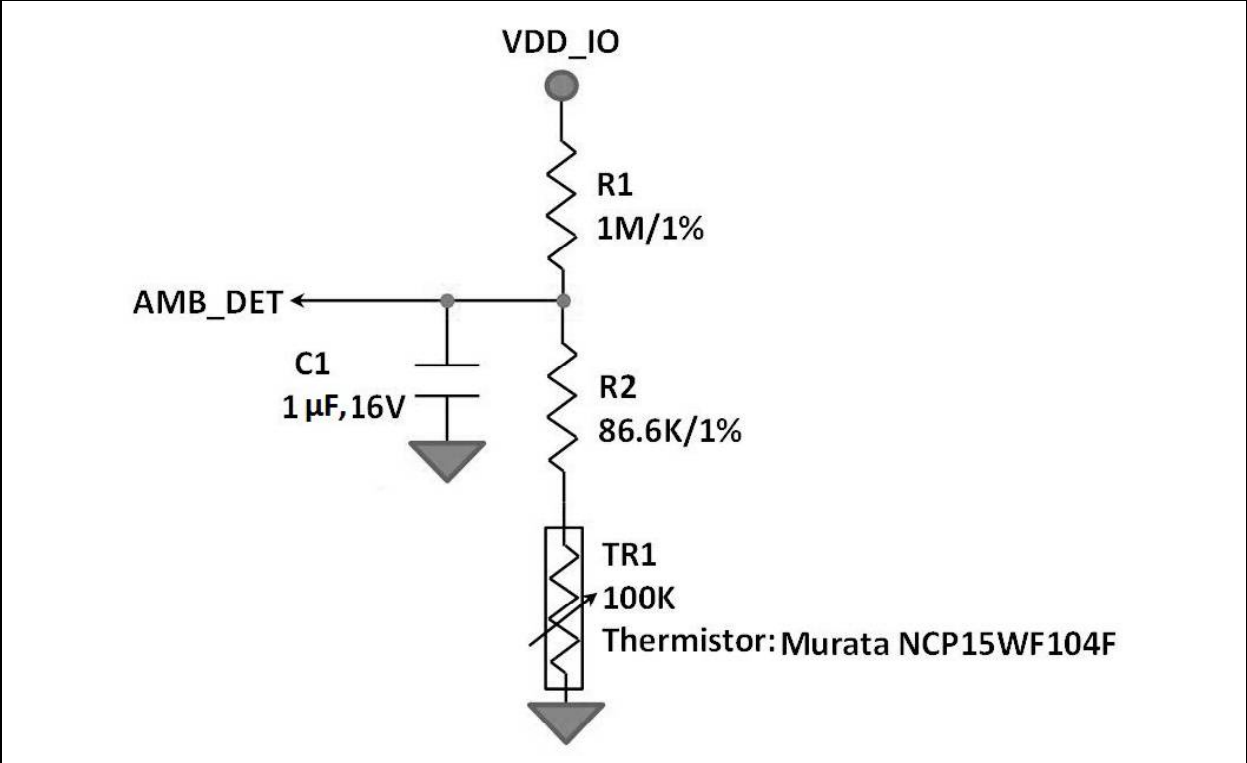

## 5.0 APPLICATION INFORMATION

The IS2062/64 SoC is powered through the BAT\_IN input pin. The external 5V power adapter can be connected to ADAP\_IN in order to charge the battery.

### 5.1 Power Supply

The following figure illustrates the connection from the BAT\_IN pin to various other voltage supply pins of the IS2062/64 SoC.

**FIGURE 5-1: POWER TREE DIAGRAM**

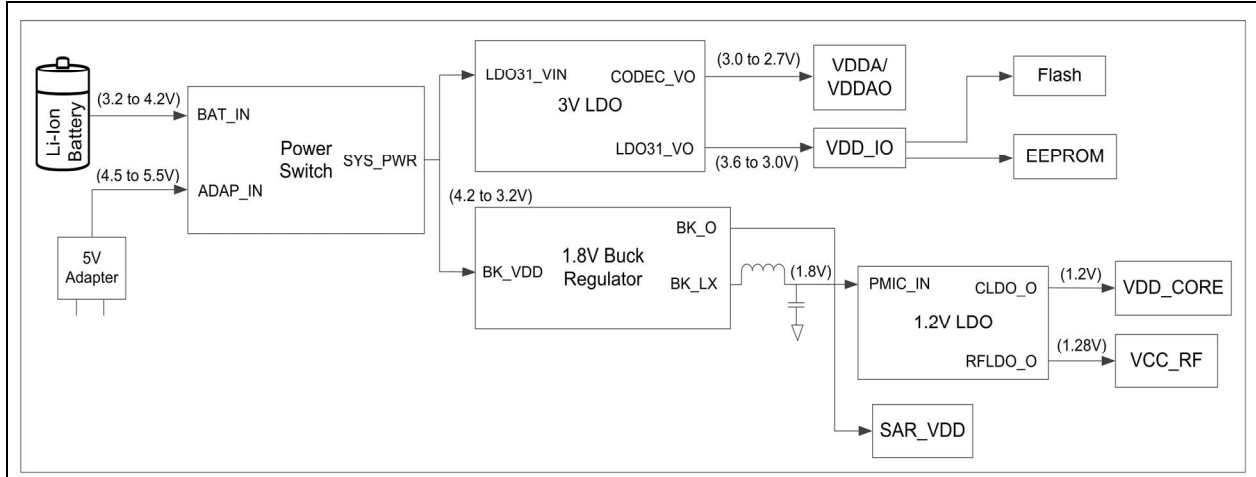

### 5.2 Host MCU Interface

The BM62/64 module supports UART commands. The UART commands enable an external MCU to control the BM62/64 module. Figure 5-2 illustrates the UART interface between the BM62/64 module and an external MCU.

**FIGURE 5-2: HOST MCU INTERFACE OVER UART**

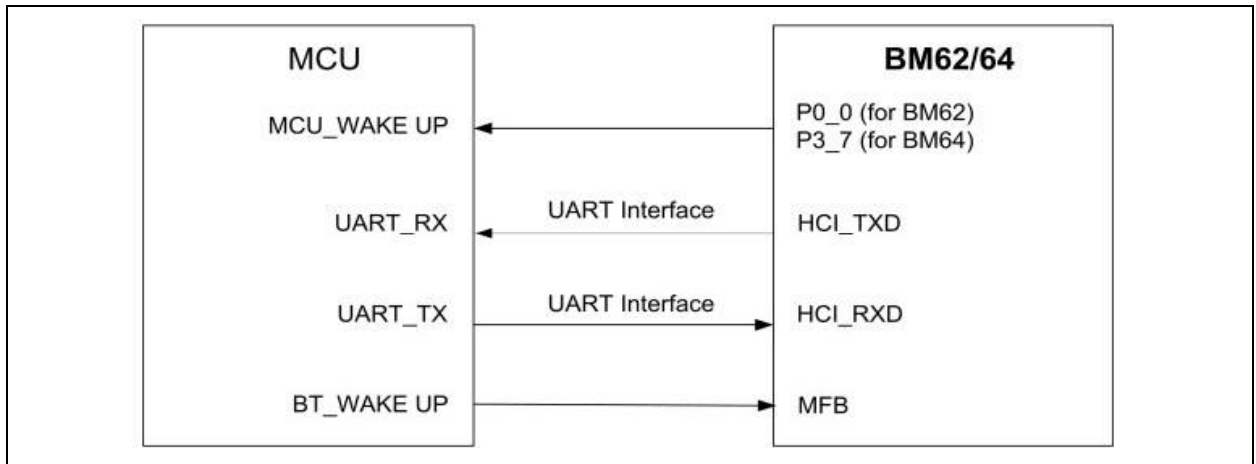

An external MCU can control the BM62/64 module over the UART interface and wake-up the module with the MFB, P0\_0 (BM62) and P3\_7 (BM64) pins.

# BM62/64

---

Refer to the "*UART\_CommandSet*" document for a list of functions the BM62/64 module supports and how to use the UI tool to configure the UART and UART Command Set tool.

**Note:** The UART Command set tool (SPKCommandSetTool v160.xx) and "*UART\_CommandSet*" document are available for download from the Microchip website at:  
[www.microchip.com/BM62](http://www.microchip.com/BM62) and  
[www.microchip.com/BM64](http://www.microchip.com/BM64).

Figure 5-3 through Figure 5-8 illustrate the timing sequences of various UART control signals.

**FIGURE 5-3: POWER-ON/OFF SEQUENCE**

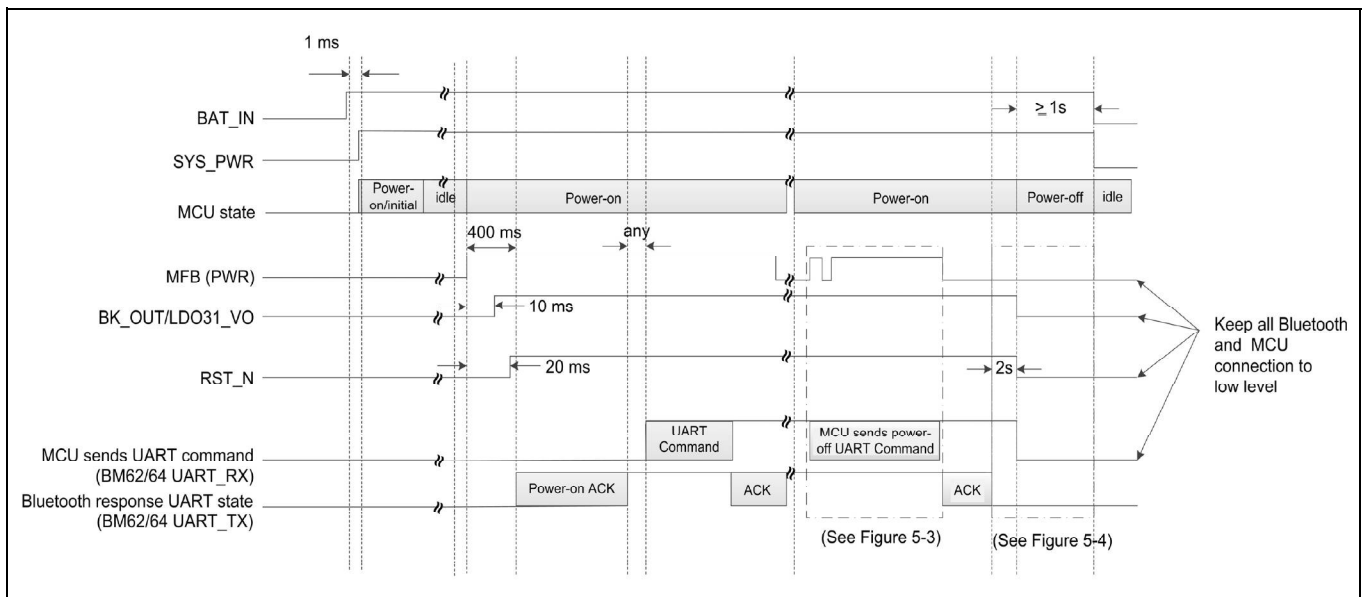

# BM62/64

**FIGURE 5-4: TIMING SEQUENCE OF RX INDICATION AFTER POWER-ON STATE**

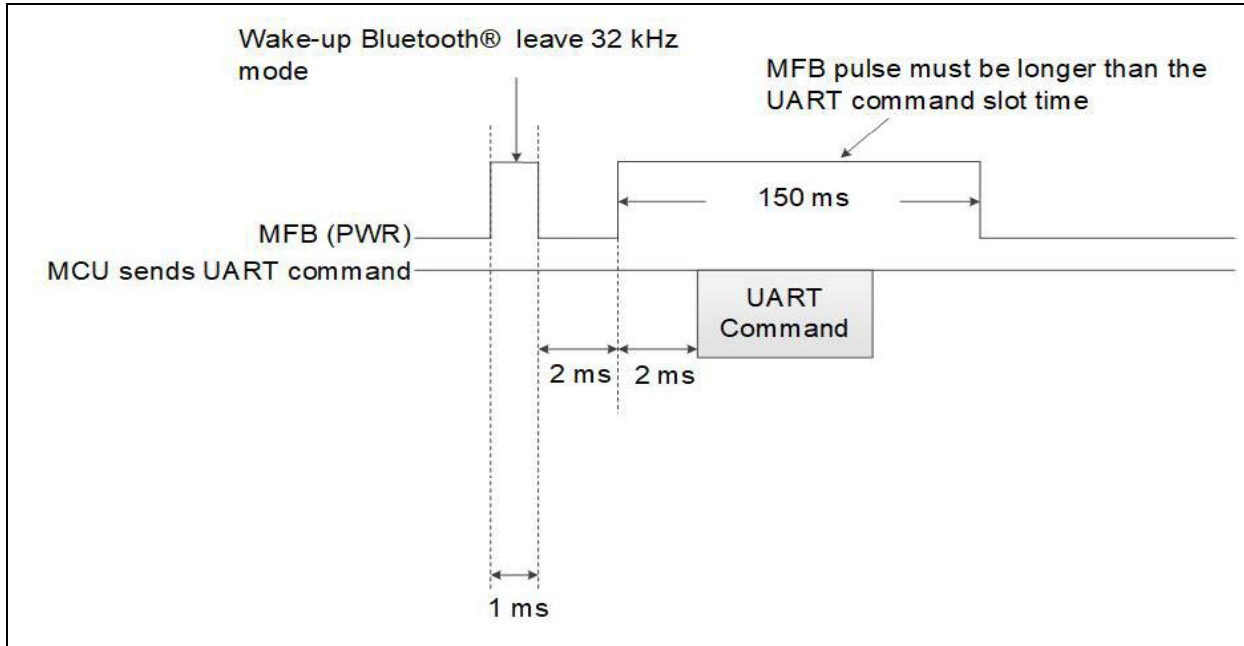

**FIGURE 5-5: TIMING SEQUENCE OF POWER-OFF STATE**

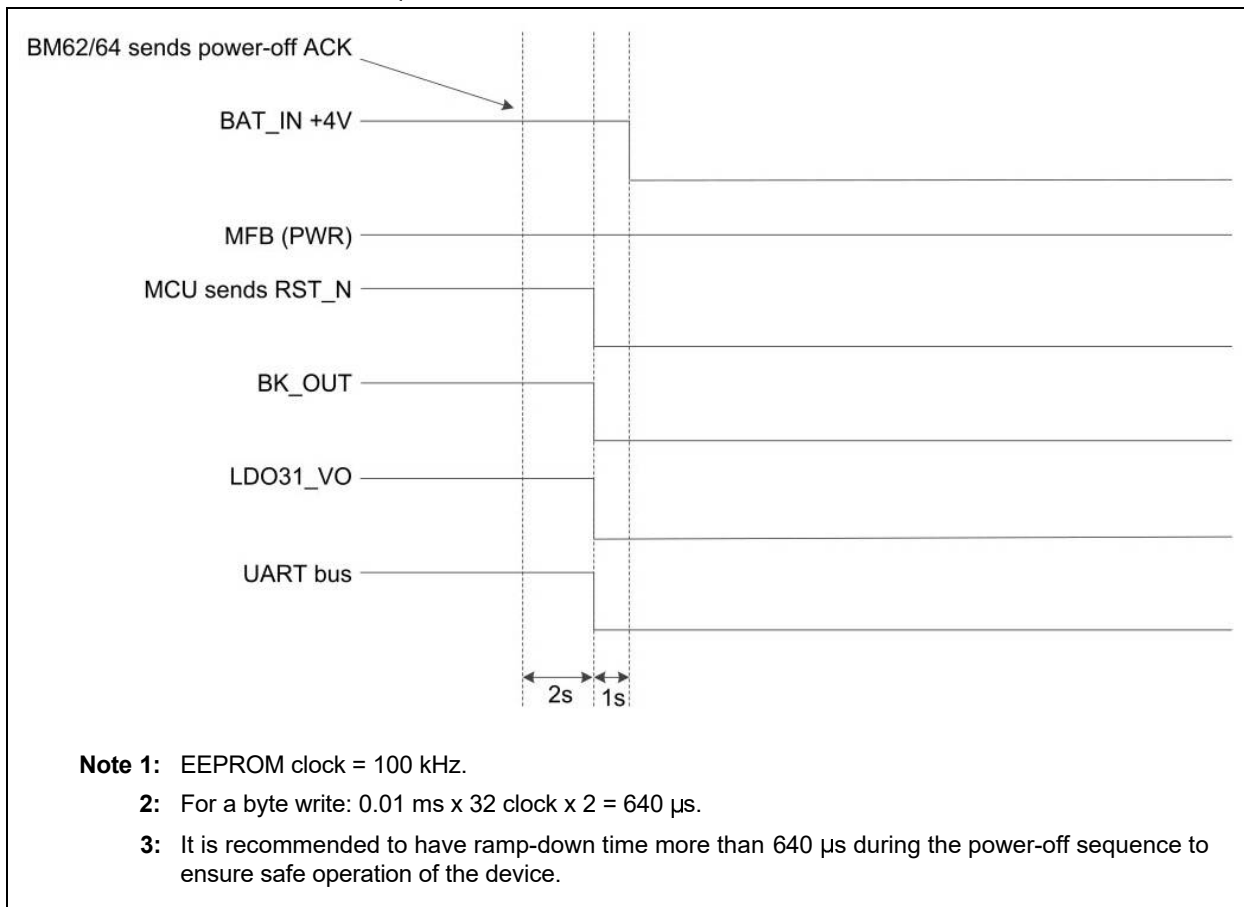

**FIGURE 5-6: TIMING SEQUENCE OF POWER-ON (NACK)**

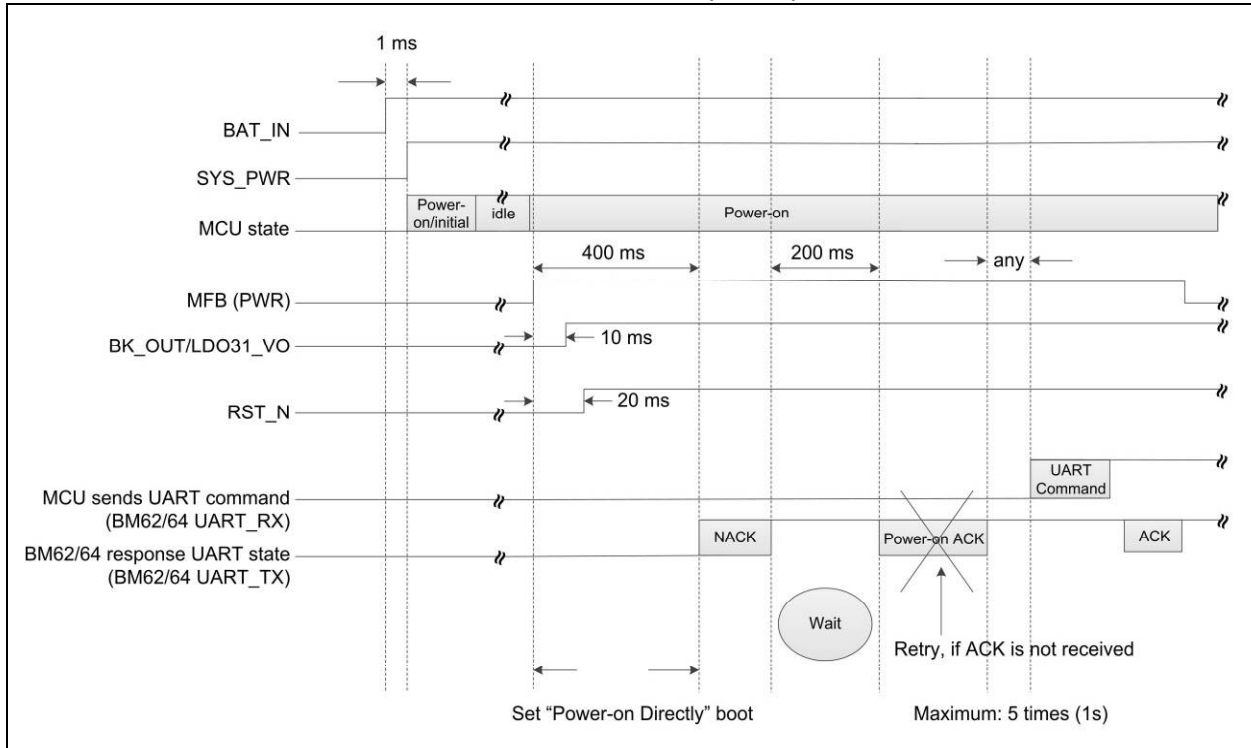

**FIGURE 5-7: RESET TIMING SEQUENCE IN NO RESPONSE FROM MODULE TO HOST MCU**

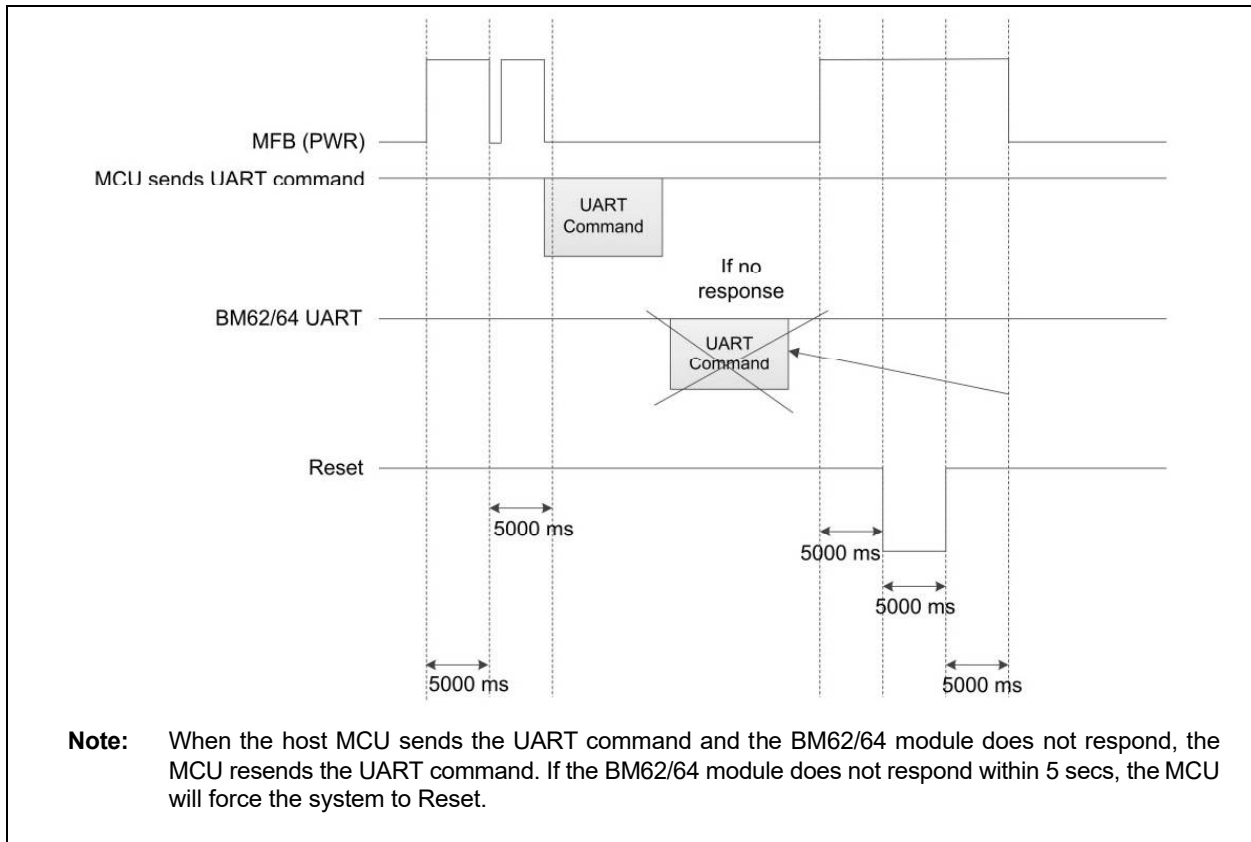



# BM62/64

**FIGURE 5-8: TIMING SEQUENCE OF POWER DROP PROTECTION**

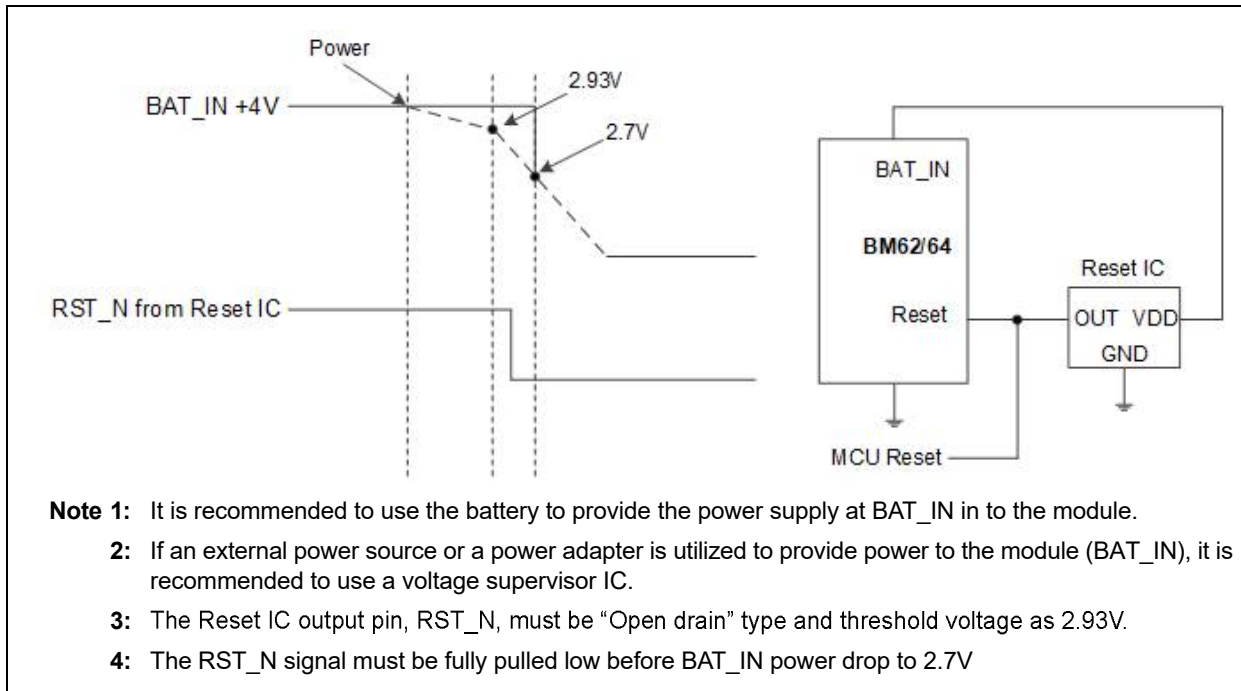

## 5.2.1 DEVICE FW UPGRADE (DFU)

After receiving all the images and storing in local memory, such as SPI flash/USB thumb drive, the MCU conducts the DFU for BT Module.

### 5.2.1.1 Enter BT Module/MCU DFU mode

To upgrade the flash through UART, first select the module in “ROM TEST” mode.

The timing for BM64 to enter “ROM TEST” mode is illustrated in following figure (P20 low and EAN high).

**FIGURE 5-9: Timing Diagram of Application Mode to DFU Mode**

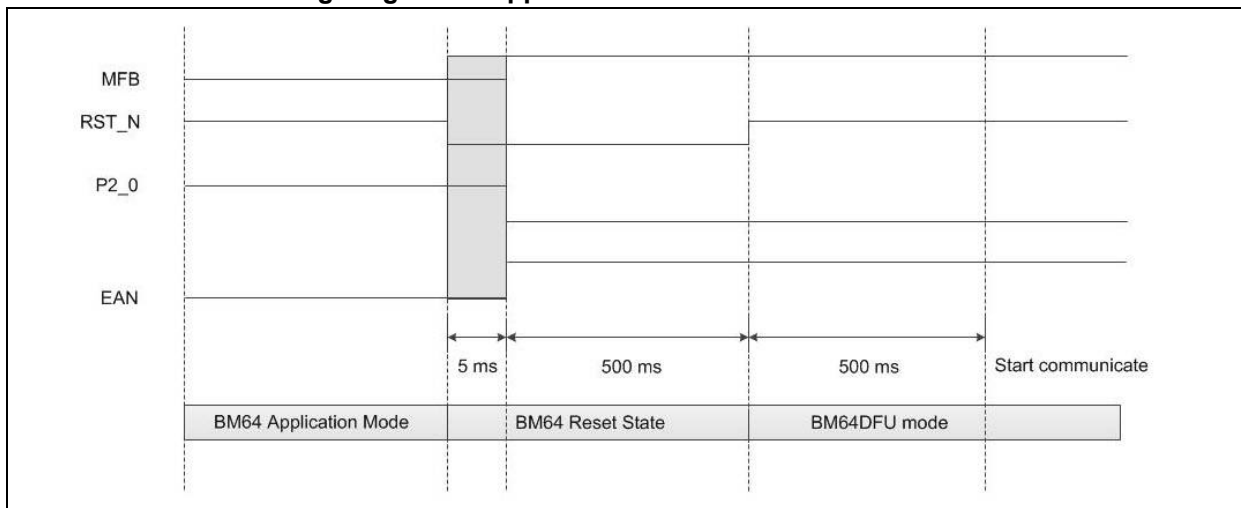

Be sure to switch back from “ROM TEST/DFU” mode to Application mode, after the DFU, as illustrated in following figure.

**FIGURE 5-10: Timing Diagram of DFU Mode to Application Mode**

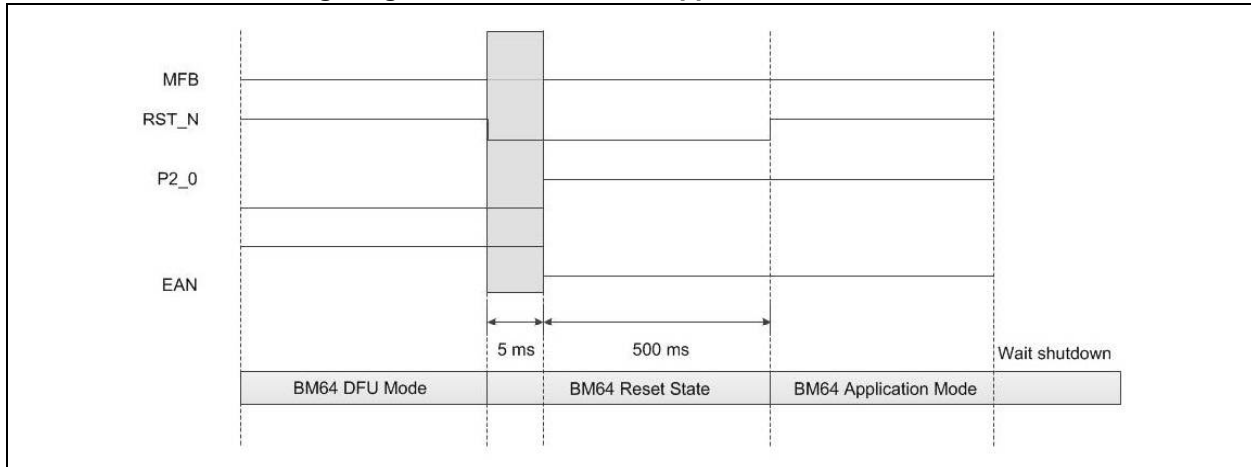

### 5.3 I<sup>2</sup>S Mode Application

The BM64 module provides an I<sup>2</sup>S digital audio output interface to connect with an external codec/DSP. It provides 8, 16, 44.1, 48, 88.2, and 96 kHz sampling rates for 16-bit and 24-bit data formats. The I<sup>2</sup>S setting can be configured by using the UI and DSP tools.

Figure 5-11 and Figure 5-12 illustrate the I<sup>2</sup>S signal connection between the BM64 module and an external DSP. Use the DSP tool to configure the BM64 module as a host/client.

For additional information on timing specifications, refer to [8.1 “Timing Specifications”](#).

**FIGURE 5-11: BM64 MODULE IN I<sup>2</sup>S HOST MODE**

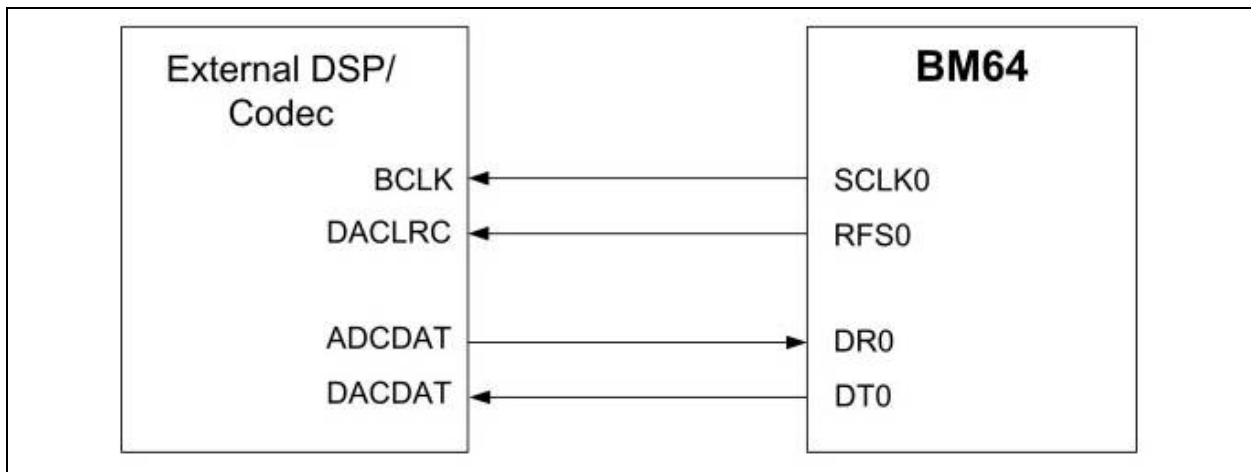

# BM62/64

FIGURE 5-12: BM64 MODULE IN I<sup>2</sup>S CLIENT MODE

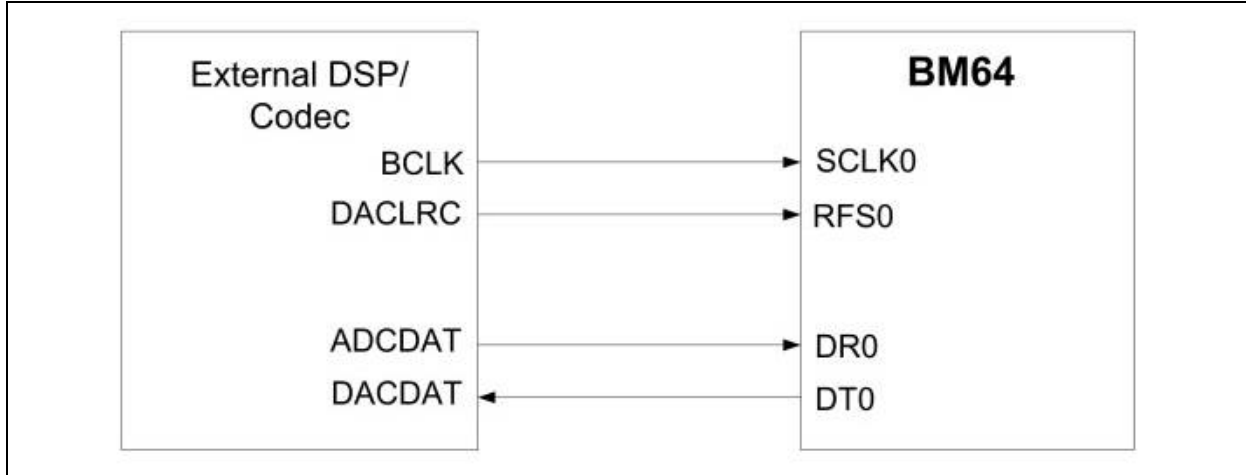

## 5.4 Reset

The BM62/64 module provides a Watchdog Timer (WDT) to reset the chip. It has an integrated Power-on Reset (POR) circuit that resets all circuits to a known power-on state. This action can be driven by an external reset signal, which is used to control the device externally by forcing it into a POR state. The RST\_N signal input is active-low and no connection is required in most applications.

## 5.5 External Configuration and Programming

The BM62/64 module can be configured by using an external configuration tool (EEPROM tool) and the firmware is programmed by using a programming tool (Flash tool).

**Note:** The EEPROM and Flash tools are available for download from the Microchip web site at: [www.microchip.com/BM62](http://www.microchip.com/BM62) and [www.microchip.com/BM64](http://www.microchip.com/BM64).

Figure 5-13 illustrates the configuration and firmware programming interface on the BM62 module. It is recommended to include a header pin on the main PCB for development.

**FIGURE 5-13: EXTERNAL PROGRAMMING HEADER CONNECTIONS**

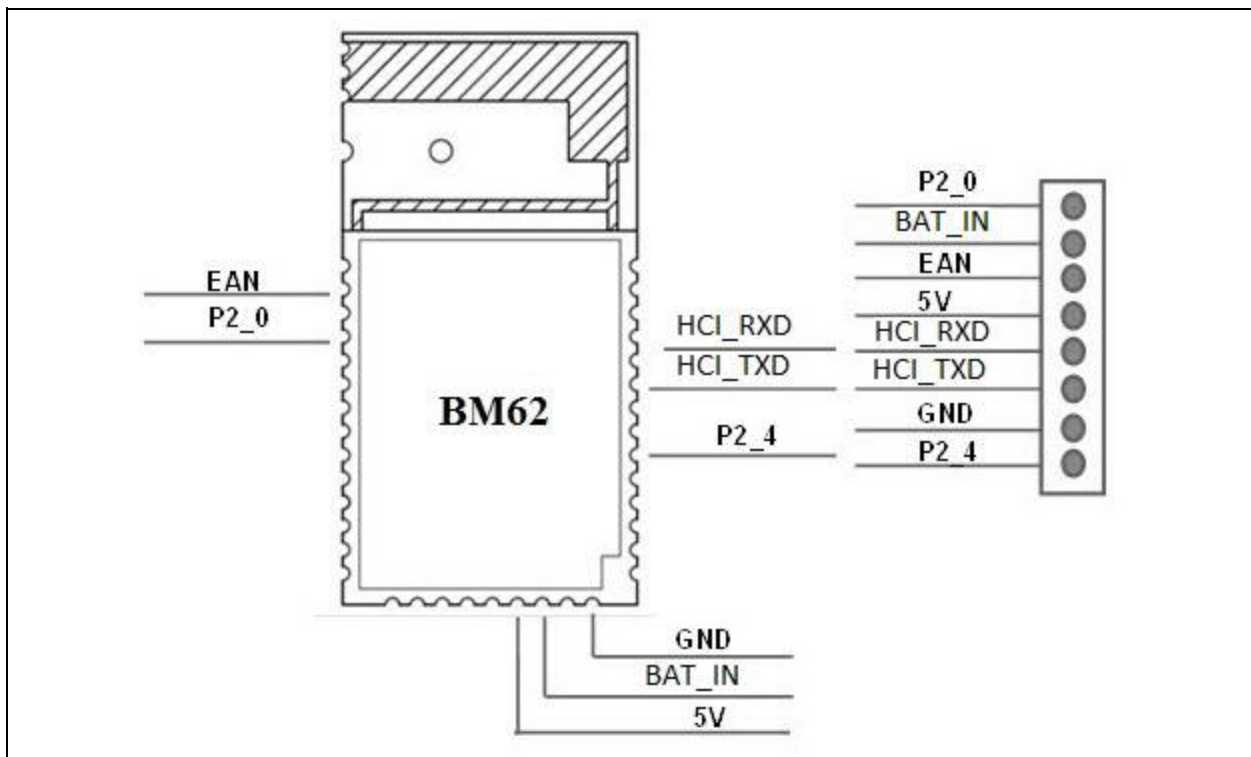

# BM62/64

---

---

The Configuration and Firmware programming modes are entered according to the system configuration I/O pins. [Table 5-1](#) provides the system configuration settings.

**TABLE 5-1: SYSTEM CONFIGURATION I/O PIN SETTINGS**

Pins			Bluetooth Mode
P2_0	EAN	P2_4	
High	Low	High	Flash Application
High	High	High	ROM Application
Low	Low	High	Flash IBDK
Low	High	High	ROM IBDK
Low	High	Low	Boot

**Note 1:** The P2\_0, P2\_4 and EAN pins have internal pull high.

**2:** Boot mode is not supported in the BM64 module, as the P2\_4 pin does not exist on the module.

### 5.6 Reference Circuit

Figure 5-14 through Figure 5-17 illustrate the BM62 module reference circuit for a stereo headset applications.

FIGURE 5-14: BM62 REFERENCE CIRCUIT FOR STEREO HEADSET APPLICATION

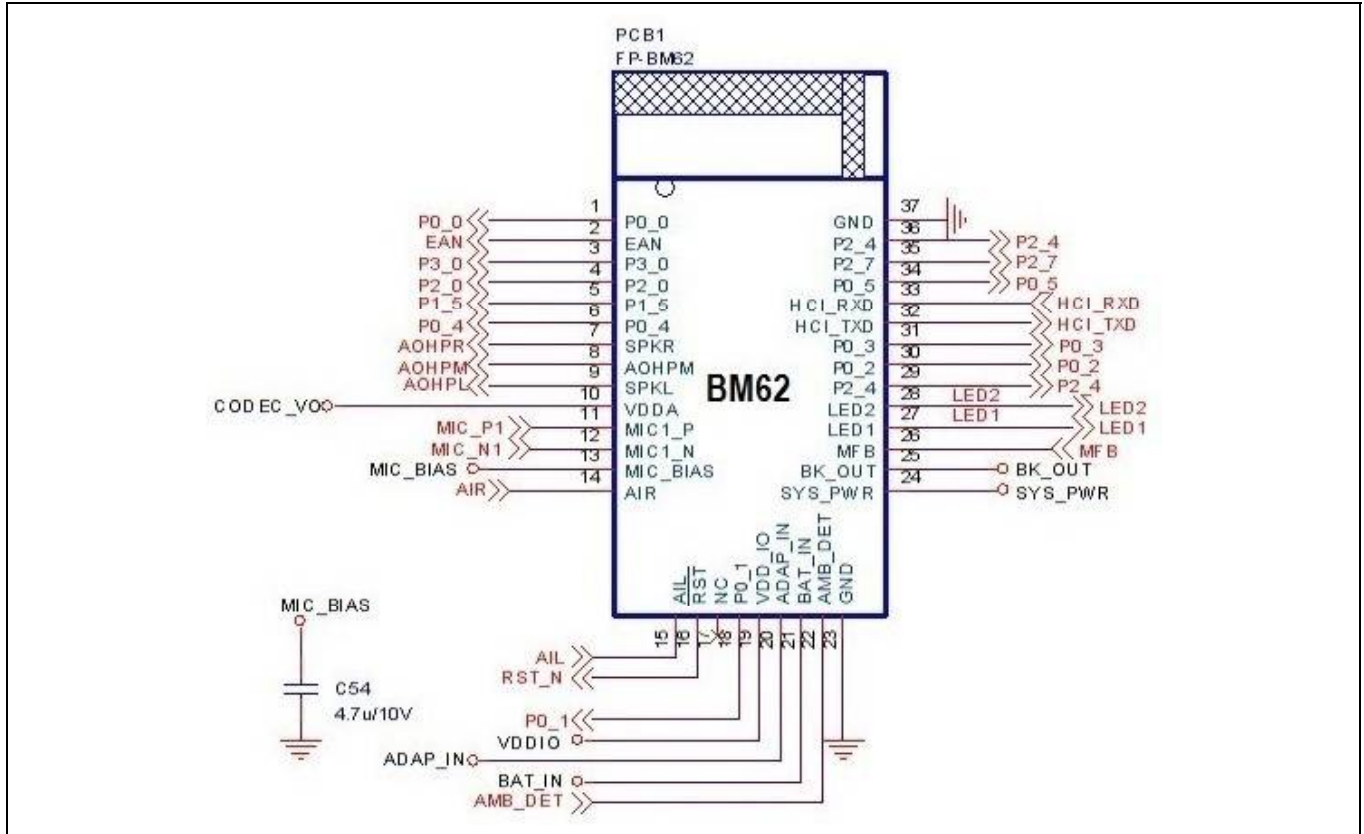
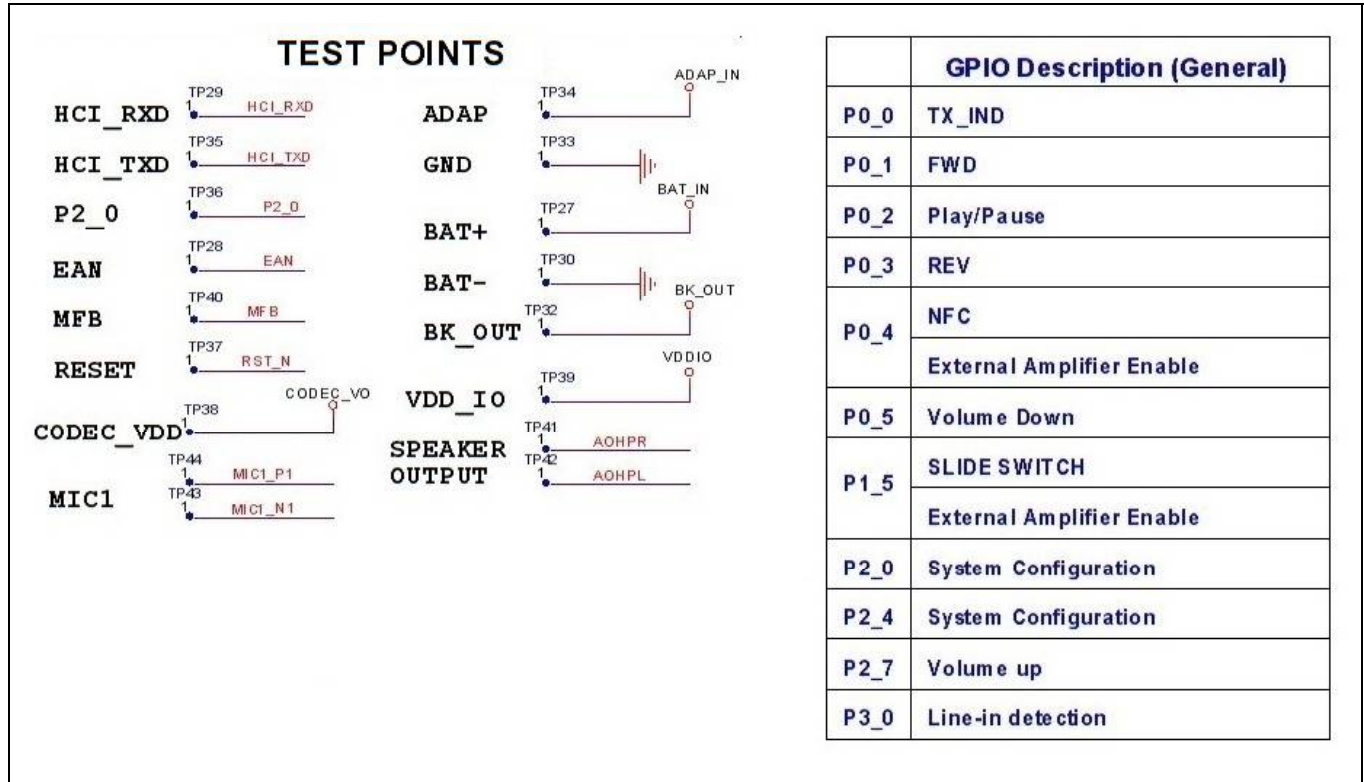
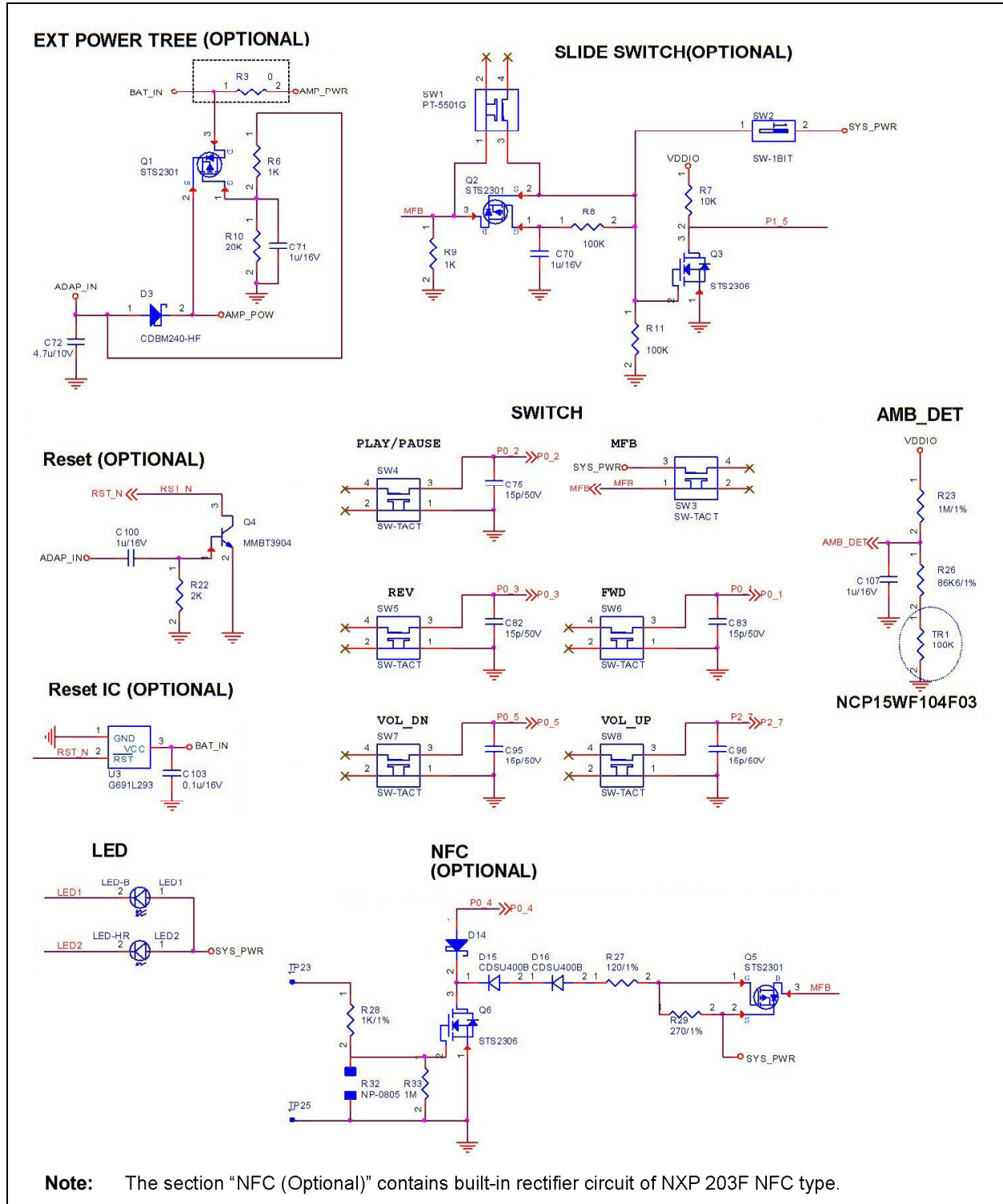

FIGURE 5-15: BM62 REFERENCE CIRCUIT FOR STEREO HEADSET APPLICATION



**FIGURE 5-16: BM62 REFERENCE CIRCUIT FOR STEREO HEADSET APPLICATION**





**FIGURE 5-17: BM62 REFERENCE CIRCUIT FOR STEREO HEADSET APPLICATION**

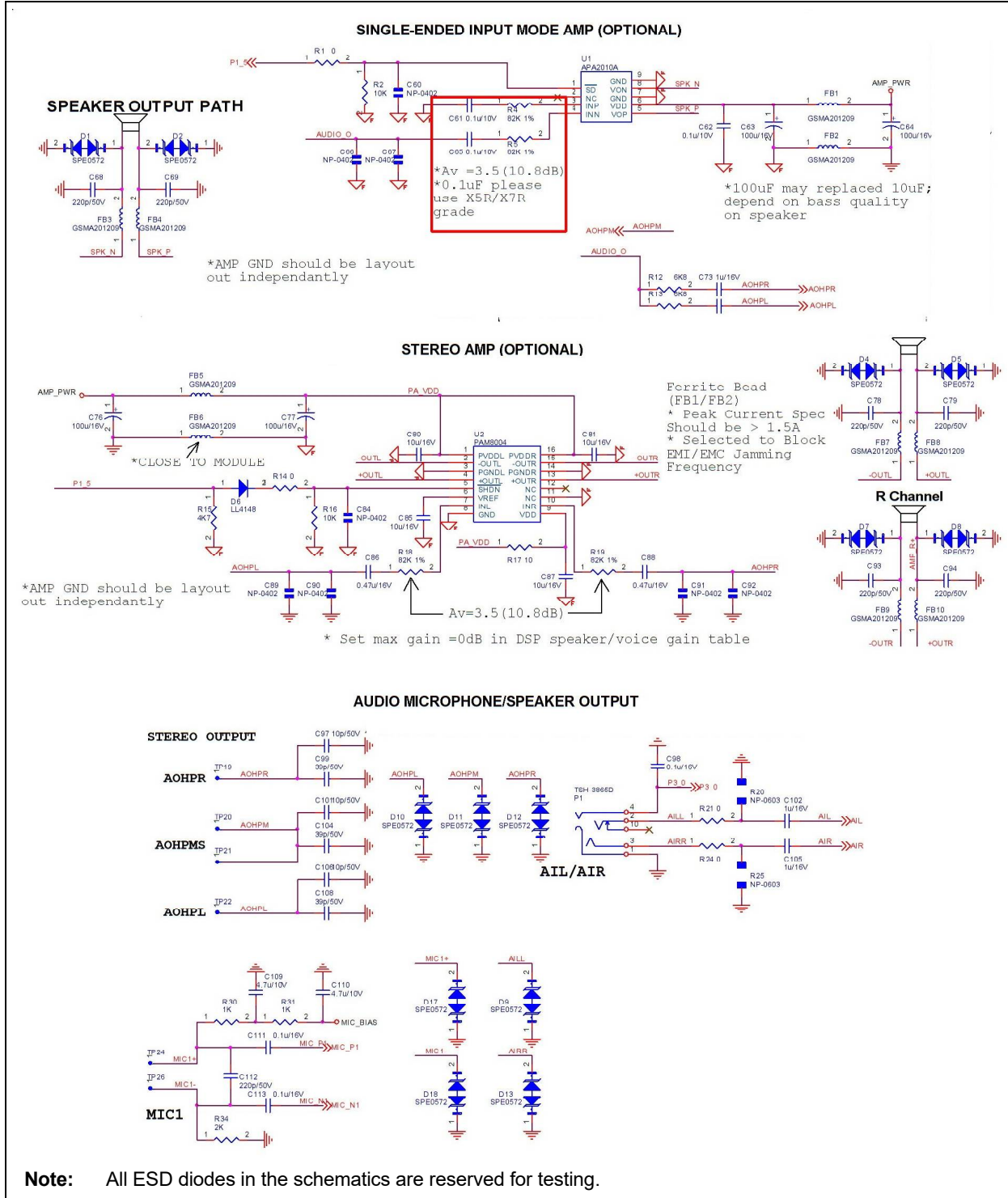

Figure 5-18 through Figure 5-21 illustrate the BM64 reference circuit for a stereo headset applications.

**FIGURE 5-18: BM64 REFERENCE CIRCUIT FOR STEREO HEADSET APPLICATION**

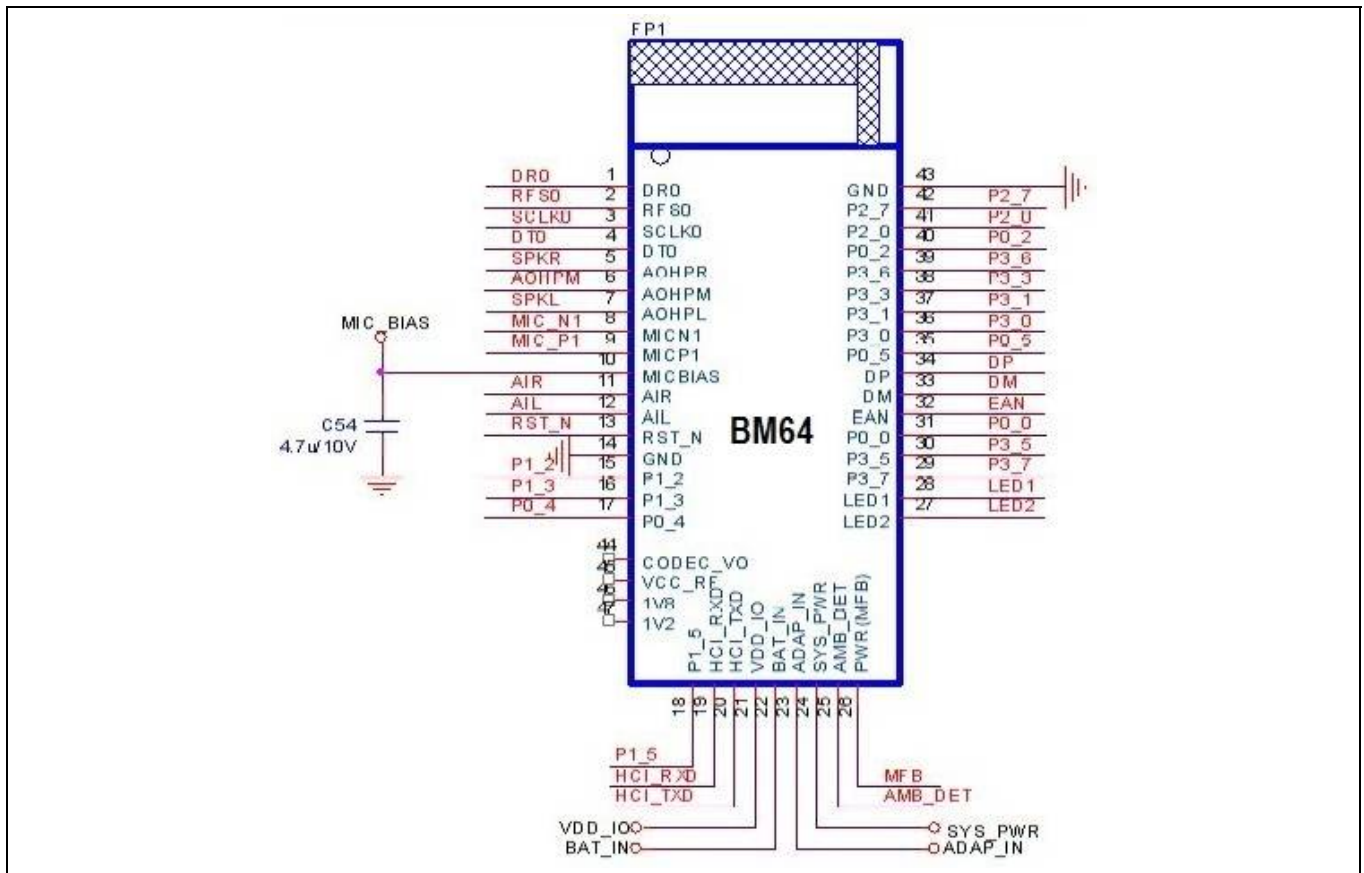
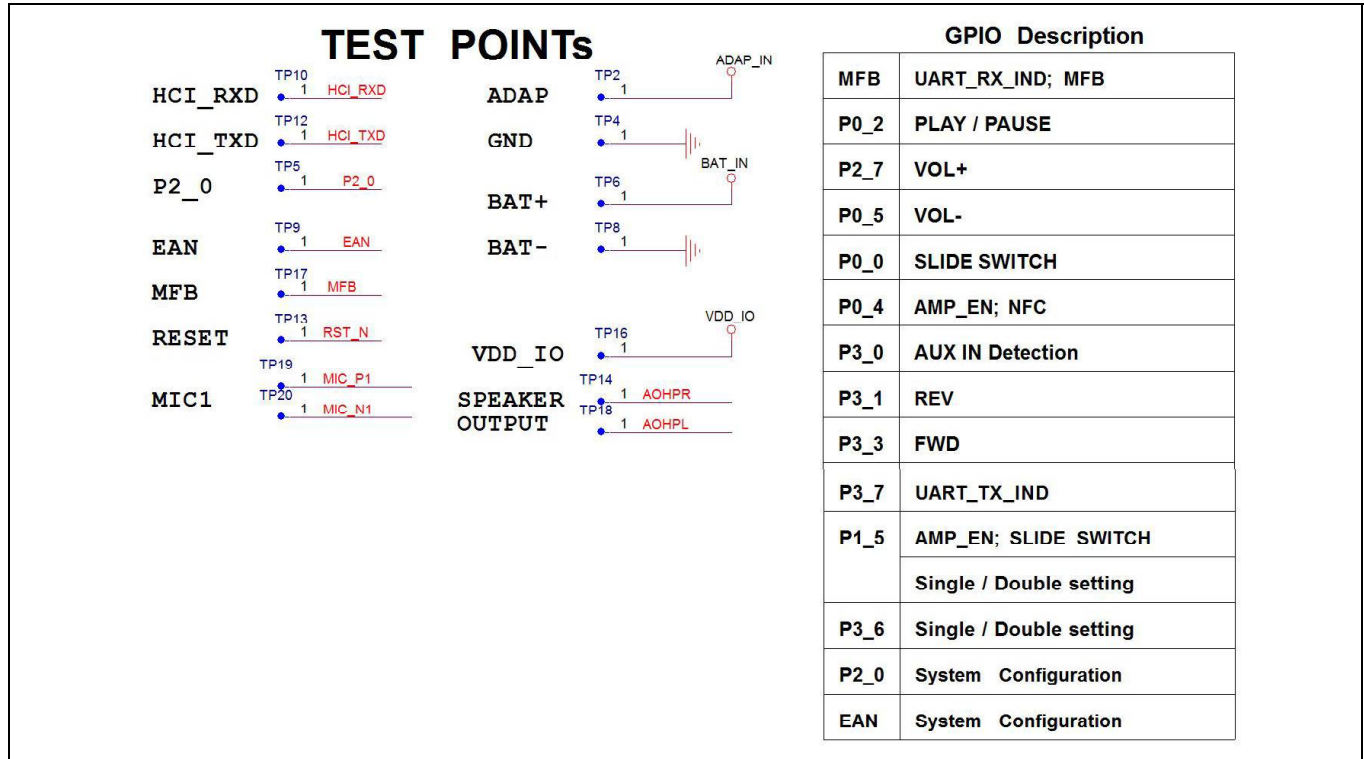
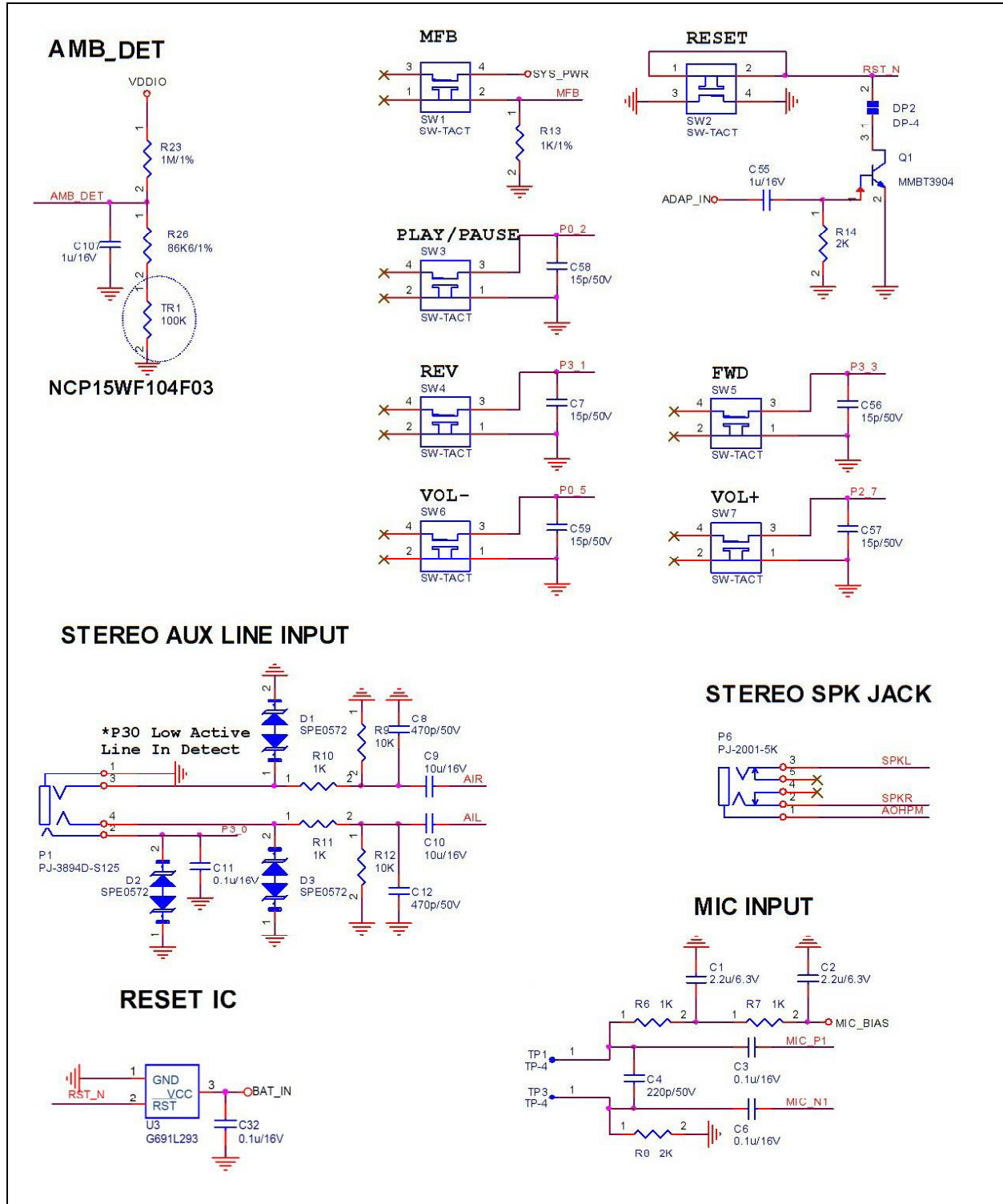

FIGURE 5-19: BM64 REFERENCE CIRCUIT FOR STEREO HEADSET APPLICATION

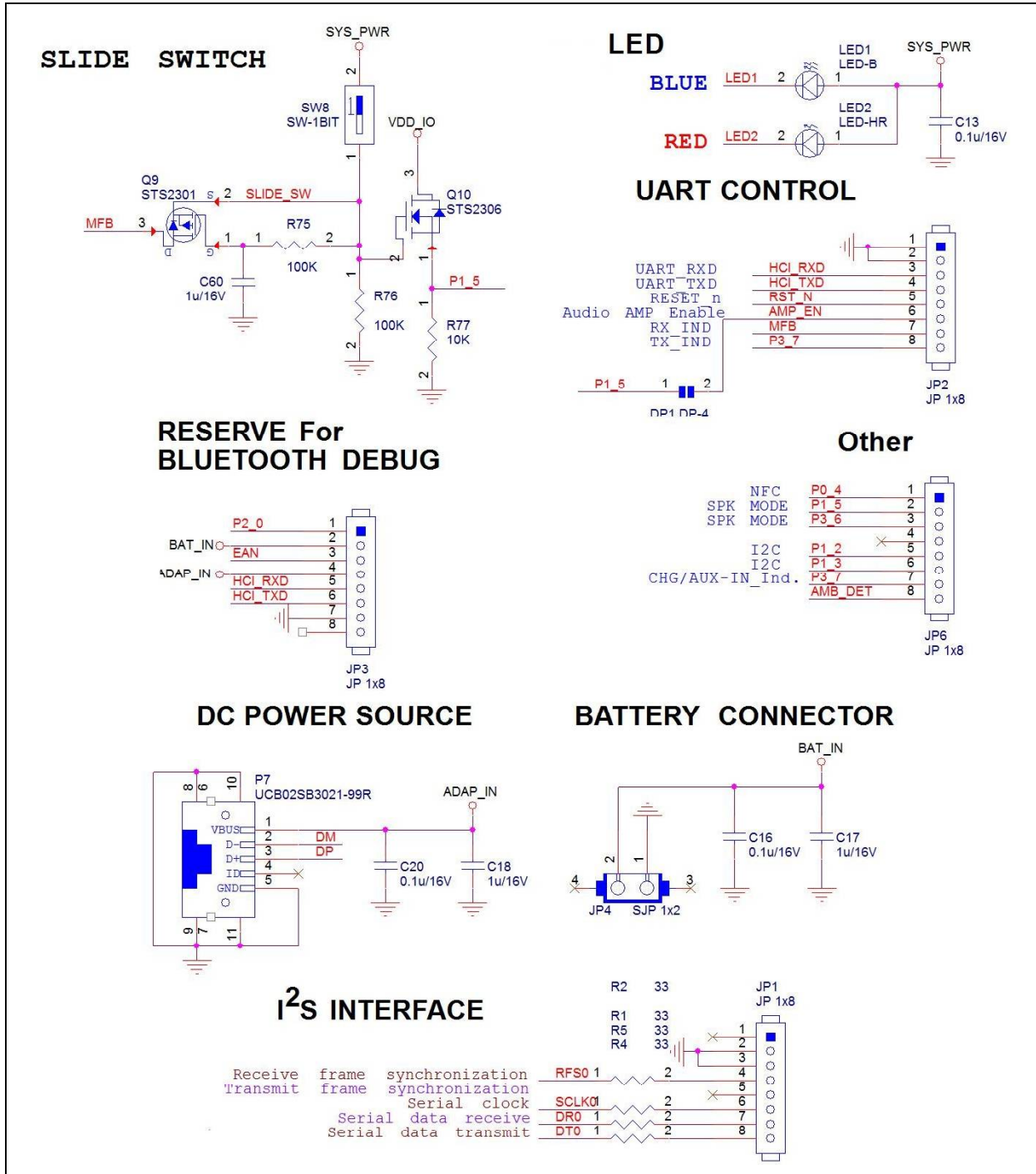

**FIGURE 5-20: BM64 REFERENCE CIRCUIT FOR STEREO HEADSET APPLICATION**



# BM62/64

FIGURE 5-21: BM64 REFERENCE CIRCUIT FOR STEREO HEADSET APPLICATION



## 6.0 PRINTED ANTENNA INFORMATION

### 6.1 Antenna Radiation Pattern

The BM62/64 module is integrated with one PCB printed antenna, see [Figure 6-1](#).

**FIGURE 6-1: RECOMMENDED KEEPOUT AREA FOR PCB ANTENNA**

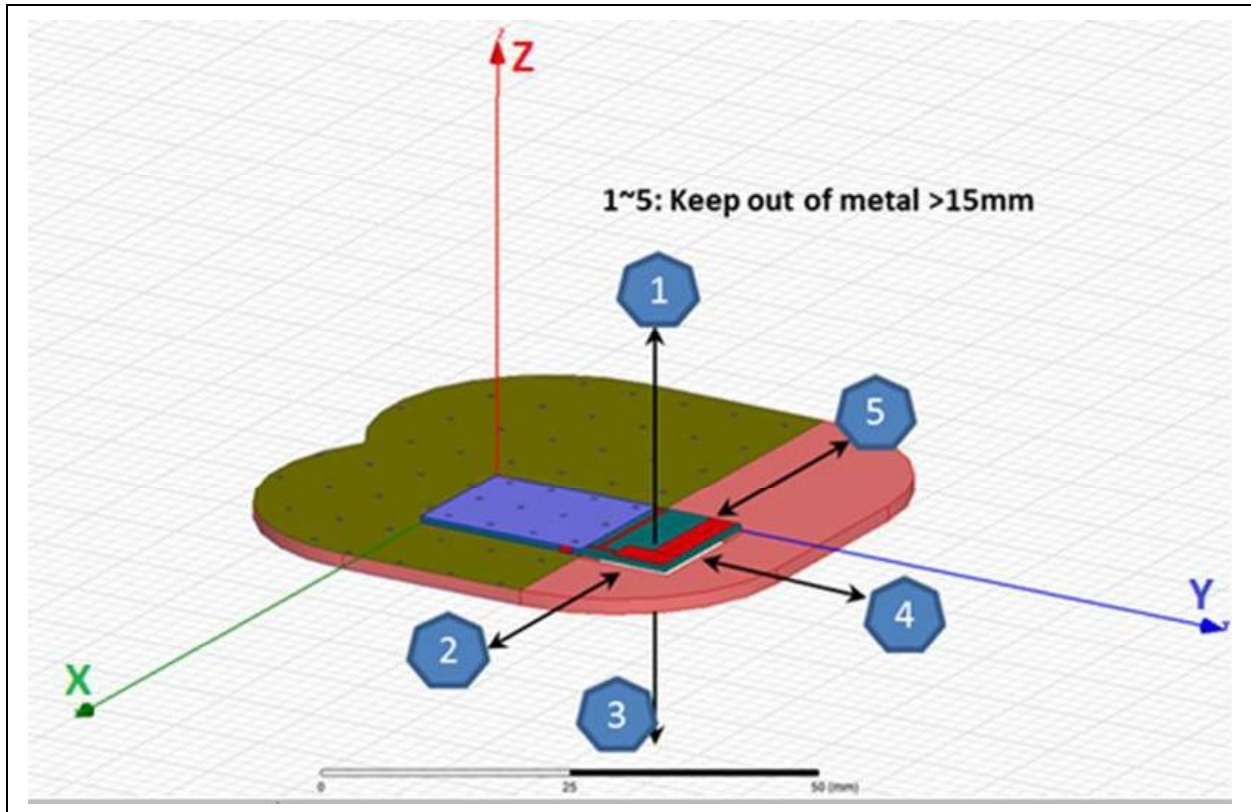

# BM62/64

Figure 6-2 illustrates the 3D radiation pattern of the PCB printed antenna at 2441 MHz.

**FIGURE 6-2: PCB ANTENNA 3D RADIATION PATTERN AT 2441 MHz**

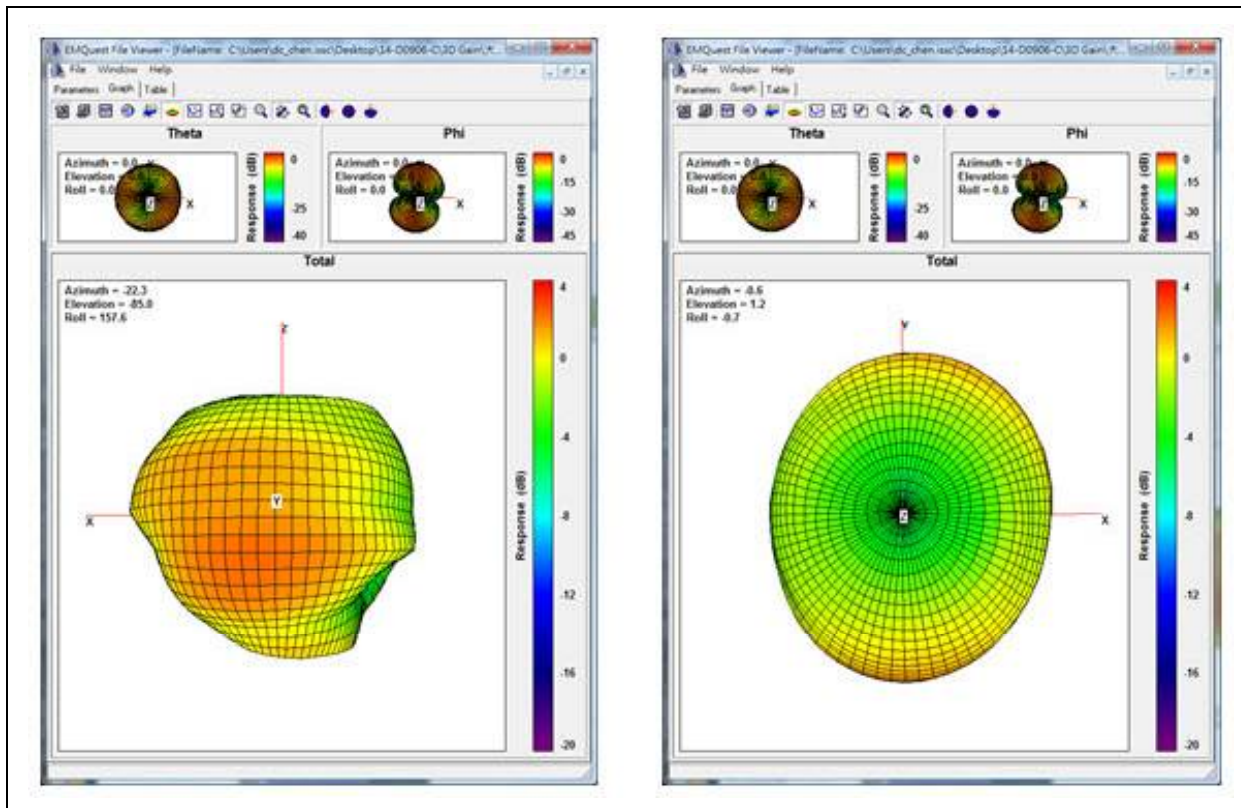

Table 6-1 provides the PCB Antenna characteristics of the BM62/64 module.

noise reduction. For the best range performance, keep all external metal at least 15 mm away from the on-board PCB trace antenna.

**TABLE 6-1: BM62/64 PCB ANTENNA CHARACTERISTICS**

Parameter	Values
Frequency	2400 MHz to 2480 MHz
Peak Gain	1.927 dBi
Efficiency	73.41%

## 6.2 Module Placement Guidelines

For a Bluetooth-enabled product, the antenna placement affects the overall performance of the system. The antenna requires free space to radiate RF signals and it must not be surrounded by the ground plane. Microchip recommends that the areas underneath the antenna on the host PCB must not contain copper on the top, inner, or bottom layers, as illustrated in Figure 6-1.

A low-impedance ground plane will ensure the best radio performance (best range, lowest noise). The ground plane can be extended beyond the minimum recommendation, as required for the main PCB EMC

Figure 6-3 and Figure 6-4 illustrate the examples of good and poor placement of the BM62/64 module on a host board with GND plane.

**FIGURE 6-3: MODULE PLACEMENT GUIDELINES**

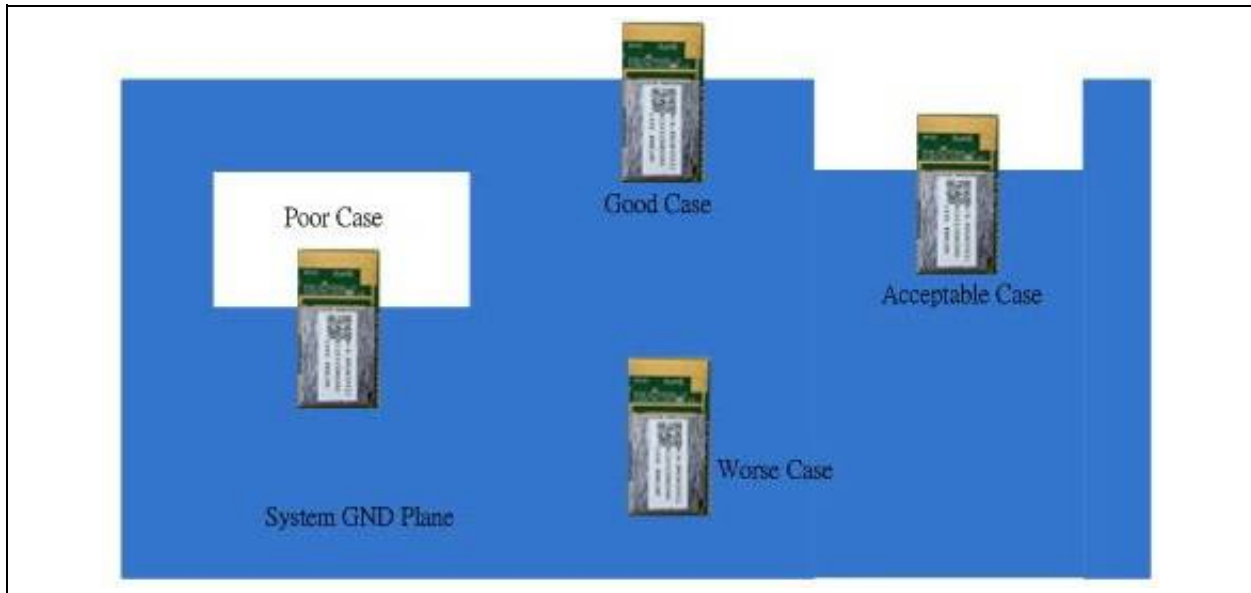

**FIGURE 6-4: GND PLANE ON MAIN APPLICATION BOARD**

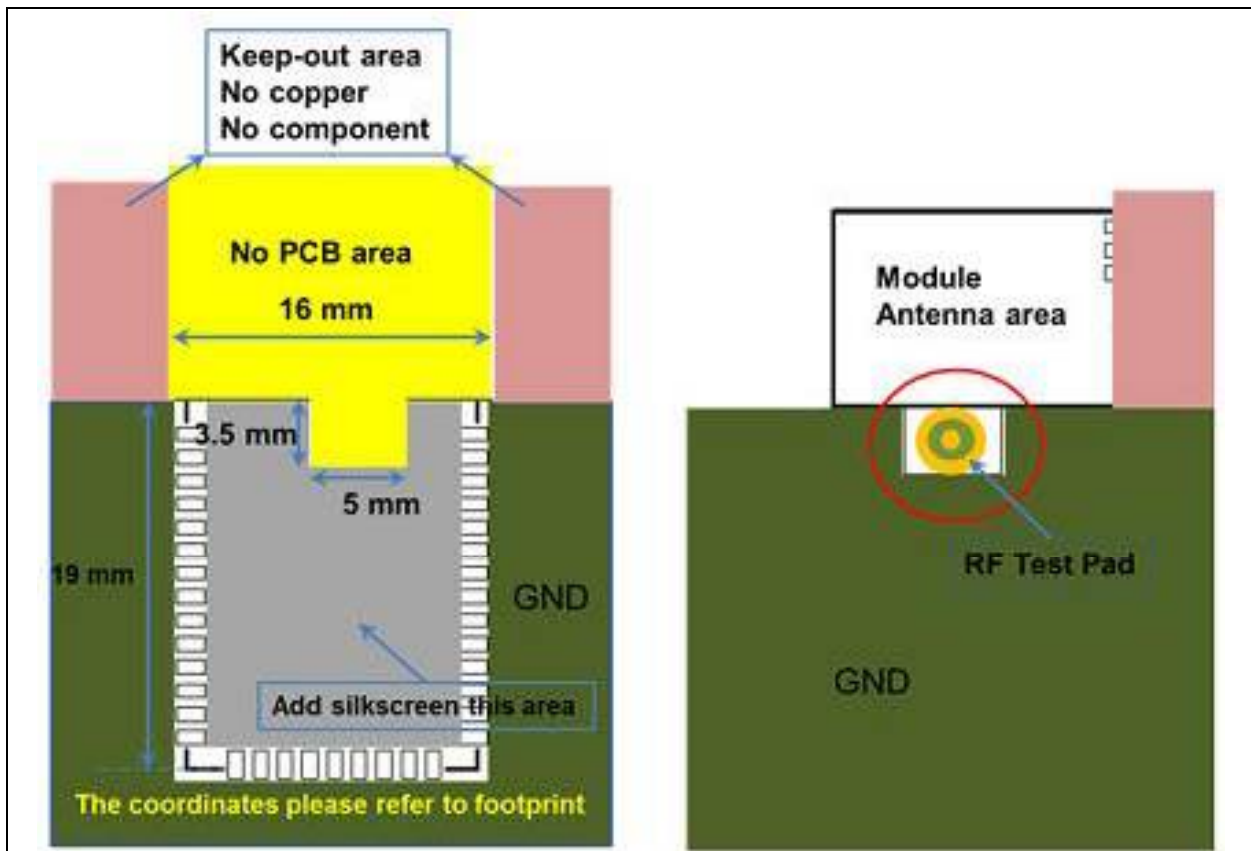



# BM62/64

## 7.0 PHYSICAL DIMENSIONS

Figure 7-1 illustrates the PCB dimension of the BM62 module.

FIGURE 7-1: BM62 MODULE PCB DIMENSION

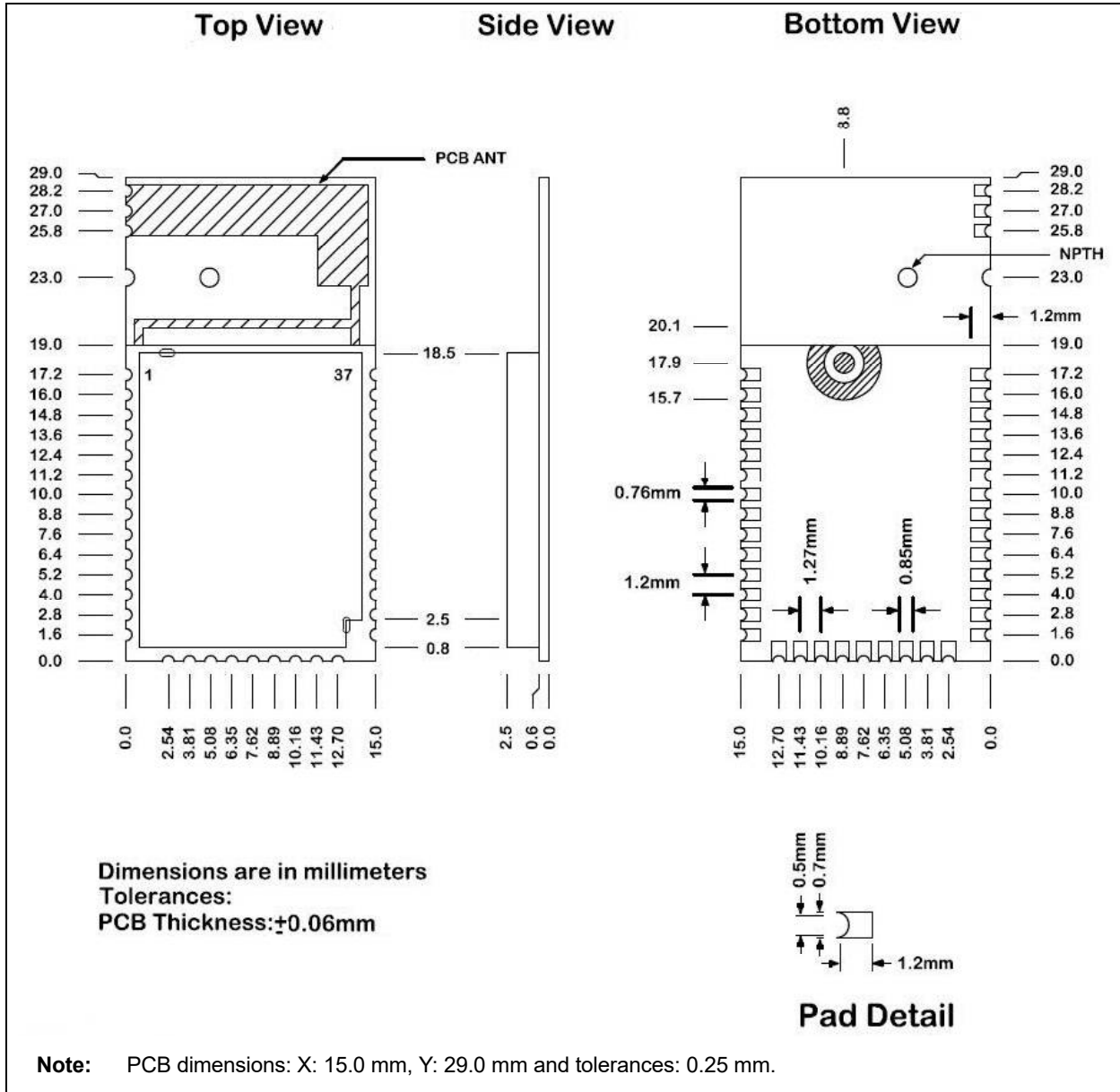
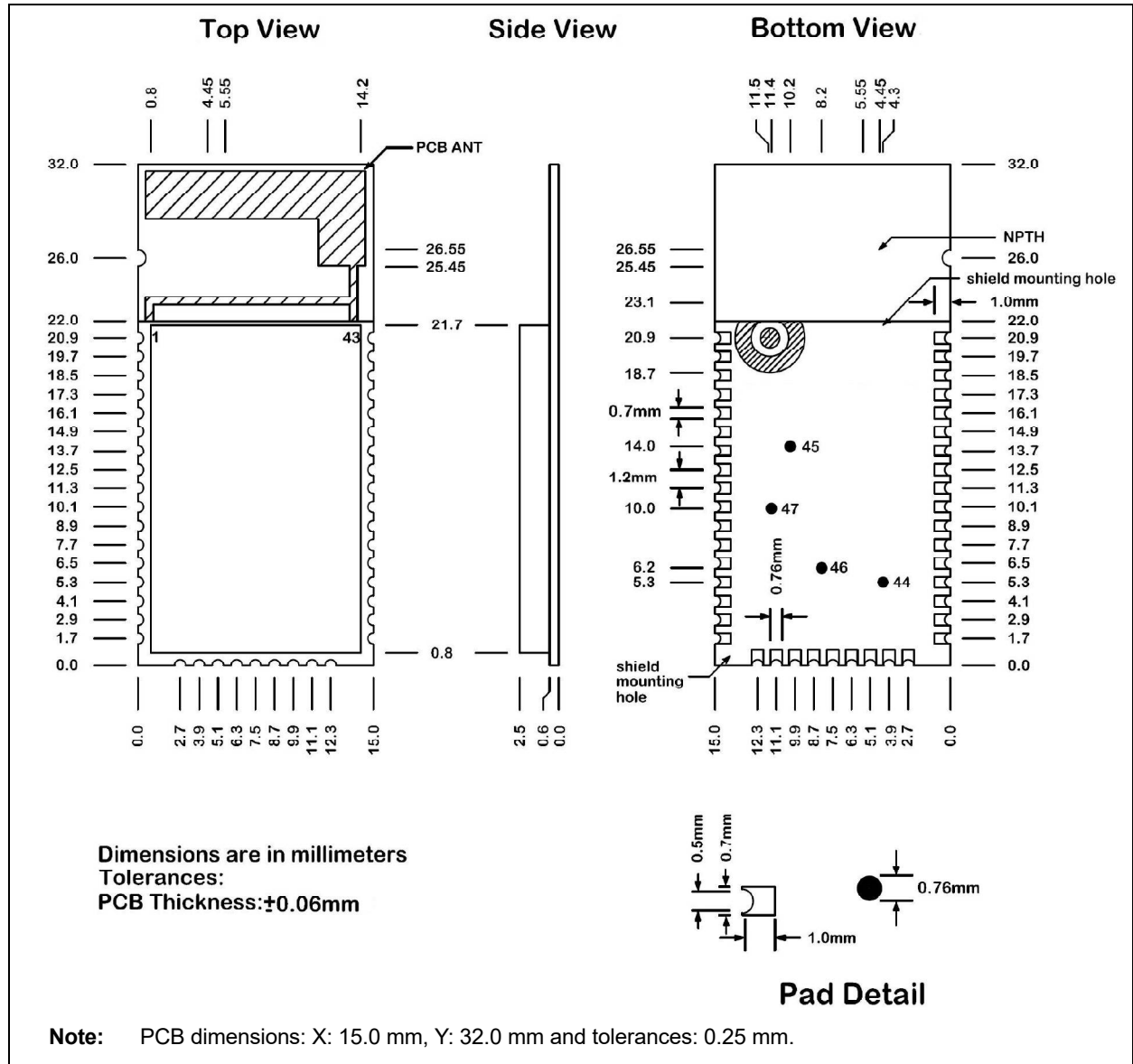

Figure 7-2 illustrates the PCB dimension of the BM64 module.

**FIGURE 7-2: BM64 MODULE PCB DIMENSION**



# BM62/64

Figure 7-3 illustrates the recommended PCB footprint of the BM62 module.

FIGURE 7-3: RECOMMENDED BM62 MODULE PCB FOOTPRINT

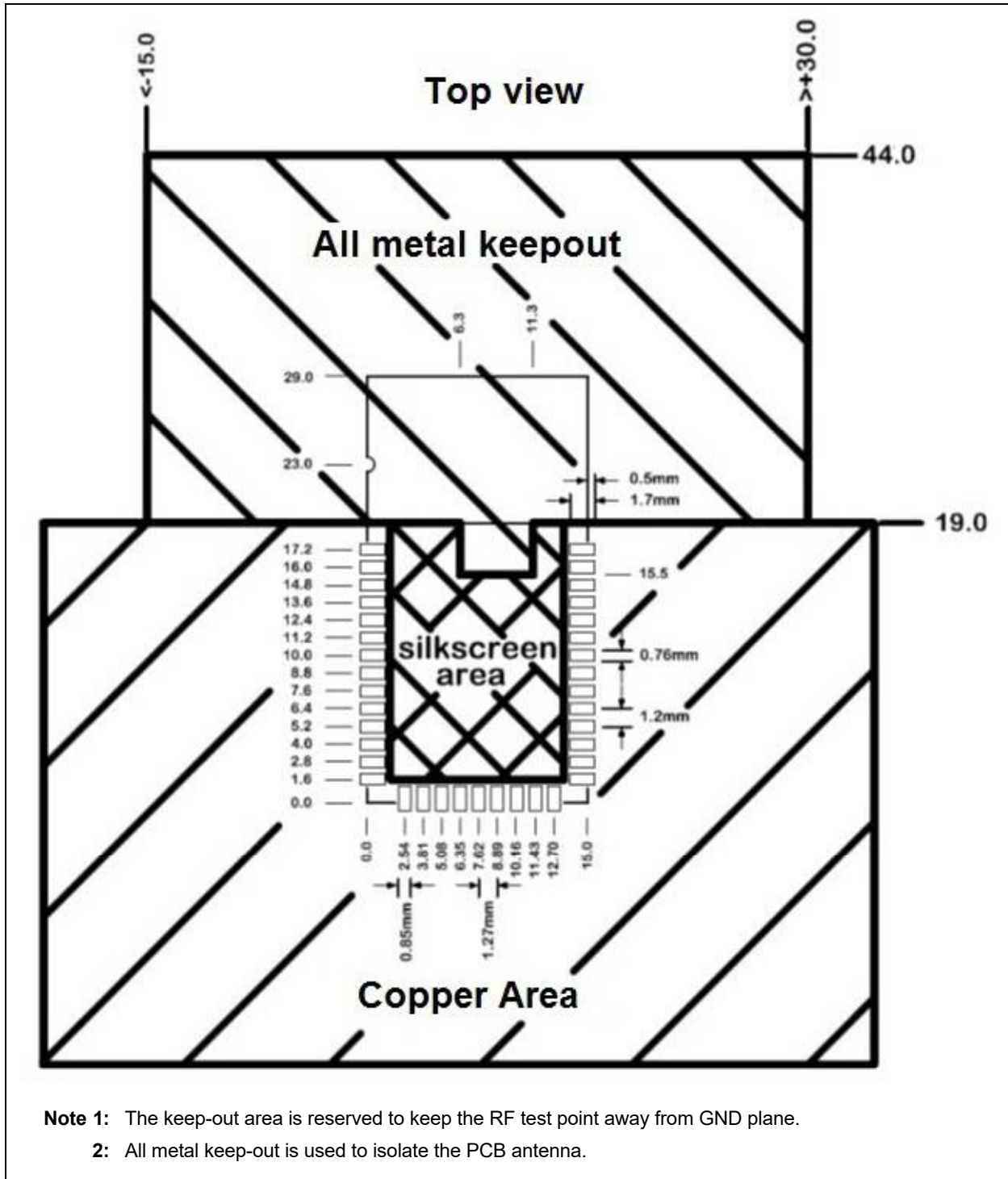
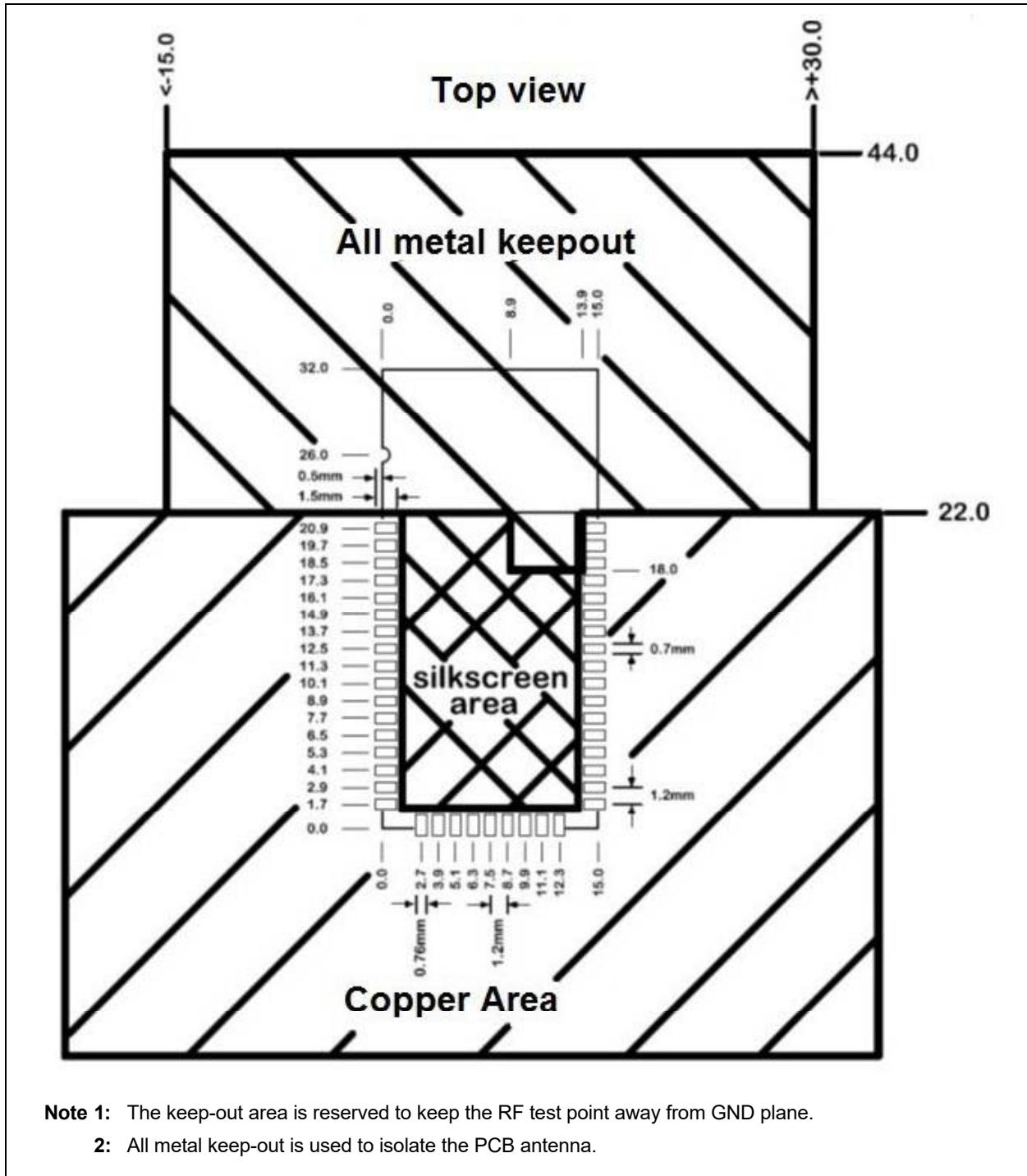

Figure 7-4 illustrates the recommended PCB footprint of the BM64 module.

**FIGURE 7-4: RECOMMENDED BM64 MODULE PCB FOOTPRINT**



# BM62/64

---

---

## 8.0 ELECTRICAL CHARACTERISTICS

This section provides an overview of the BM62/64 Stereo Audio module electrical characteristics. Additional information will be provided in future revisions of this document, as it becomes available.

Absolute maximum ratings for the BM62/64 module are listed below.

### Absolute Maximum Ratings

Ambient temperature under bias .....	-20°C to +70°C
Storage temperature .....	-40°C to +125°C
Voltage on VDD with respect to Vss .....	-0.3V to +3.6V
Maximum output current sink by any I/O pin.....	12 mA
Maximum output current sourced by any I/O pin.....	12 mA

<p><b>Note:</b> Stresses listed under “<b>Absolute Maximum Ratings</b>” may cause permanent damage to the device. This is a stress rating only. The functional operation of the device at those or any other conditions and those indicated in the operation listings of this specification, is not implied. Exposure to maximum rating conditions for extended periods may affect device reliability.</p>
--

Table 8-1 through Table 8-9 provide the recommended operating conditions and the electrical specifications of the BM62/64 module.

**TABLE 8-1: RECOMMENDED OPERATING CONDITION**

Symbol	Parameter	Min.	Typ.	Max.	Unit
BAT_IN	Input voltage for battery	3.2	3.8	4.2	V
ADAP_IN	Input voltage for adapter	4.5	5	5.5	V
TOPERATION	Operation temperature	-20	+25	+70	°C

**Note:** The absolute and recommended operating condition tables reflect a typical voltage usage for the device.

**TABLE 8-2: I/O AND RESET LEVEL**

Parameter		Min.	Typ.	Max.	Unit
I/O Supply Voltage (VDD_IO)		3.0	3.3	3.6	V
I/O Voltage Levels					
V <sub>IL</sub> input logic levels low		0	—	0.8	V
V <sub>IH</sub> input logic levels high		2.0	—	3.6	V
V <sub>OL</sub> output logic levels low		—	—	0.4	V
V <sub>OH</sub> output logic levels high		2.4	—	—	V
RST_N	Input Low to High Threshold Point	—	—	1.87	V
	Input High to Low Threshold Point	1.25	—	—	V
Threshold voltage		—	1.6	—	V

**Note:** These parameters are characterized, but not tested in manufacturing.

**TABLE 8-3: BATTERY CHARGER**

Parameter		Min.	Typ.	Max.	Unit
ADAP_IN Input Voltage		4.5	5.0	5.5	V
Supply current to charger only		—	3	4.5	mA
Maximum Battery Fast Charge Current	Headroom > 0.7V (ADAP_IN = 5V)	—	350	—	mA
	Headroom = 0.3V to 0.7V (ADAP_IN = 4.5V)	—	175 <sup>(2)</sup>	—	mA
Trickle Charge Voltage Threshold		—	3	—	V
Battery Charge Termination Current, (% of Fast Charge Current)		—	10	—	%

**Note 1:** Headroom = VADAP\_IN – VBAT

**2:** When VADAP\_IN – VBAT > 2V, the maximum fast charge current is 175 mA for thermal protection.

**3:** These parameters are characterized, but not tested in manufacturing.

# BM62/64

**TABLE 8-4: LED DRIVER**

Parameter	Min.	Typ.	Max.	Unit
Open-drain Voltage	—	—	3.6	V
Programmable Current Range	0	—	5.25	mA
Intensity Control	—	16	—	step
Current Step	—	0.35	—	mA
Power-Down Open-drain Current	—	—	1	μA
Shutdown Current	—	—	1	μA

**Note 1:** Test condition: BK\_OUT = 1.8V with +25°C temperature.

**2:** These parameters are characterized, but not tested in manufacturing.

**TABLE 8-5: AUDIO CODEC ANALOG TO DIGITAL CONVERTER**

T = 25°C, VDD = 2.8V, 1 kHz sine wave input, Bandwidth = 20 Hz to 20 kHz

Parameter (Condition)	Min.	Typ.	Max.	Unit
Resolution	—	—	16	Bit
Output Sample Rate	8	—	48	kHz
Signal-to-Noise Ratio ( <b>Note 1</b> ) (SNR at MIC or Line-in mode)	—	92	—	dB
Digital Gain	-54	—	4.85	dB
Digital Gain Resolution	—	2 to 6	—	dB
MIC Boost Gain	—	20	—	dB
Analog Gain	—	—	60	dB
Analog Gain Resolution	—	2.0	—	dB
Input full-scale at maximum gain (differential)	—	4	—	mV/rms
Input full-scale at minimum gain (differential)	—	800	—	mV/rms
3 dB bandwidth	—	20	—	kHz
Microphone mode (input impedance)	—	24	—	kOhm
THD+N (microphone input) at 30 mV/rms input	—	0.02	—	%

**Note 1:**  $f_{in} = 1$  kHz, B/W = 20 Hz to 20 kHz, A-weighted, THD+N < 1%, 150 mV<sub>PP</sub> input.

**2:** These parameters are characterized, but not tested in manufacturing.

**TABLE 8-6: AUDIO CODEC DIGITAL TO ANALOG CONVERTER**

T = 25°C, VDD = 2.8V, 1 kHz sine wave input, Bandwidth = 20 Hz to 20 kHz					
Parameter (Condition)		Min.	Typ.	Max.	Unit
Over-sampling rate		—	128	—	$f_s$
Resolution		16	—	20	Bit
Output Sample Rate		8	—	48	kHz
Signal-to-Noise Ratio ( <b>Note 1</b> ) (SNR at capless mode) for 48 kHz		—	98	—	dB
Signal-to-Noise Ratio ( <b>Note 1</b> ) (SNR at single-ended mode) for 48 kHz		—	98	—	dB
Digital Gain		-54	—	4.85	dB
Digital Gain Resolution		—	2 to 6	—	dB
Analog Gain		-28	—	3	dB
Analog Gain Resolution		—	1	—	dB
Output Voltage Full-scale Swing (AVDD = 2.8V)		495	742.5	—	mV/rms
Maximum Output Power (16 Ohm load)		—	34.5	—	mW
Maximum Output Power (32 Ohm load)		—	17.2	—	mW
Allowed Load	Resistive	—	16	O.C.	Ohm
	Capacitive	—	—	500	pF
THD+N (16 Ohm load) ( <b>Note 2</b> )		—	0.05	—	%
Signal-to-Noise Ratio (SNR at 16 Ohm load) ( <b>Note 3</b> )		—	98	—	dB

**Note 1:**  $f_{in} = 1$  kHz, B/W = 20 Hz to 20 kHz, A-weighted, THD+N < 0.01%, 0 dBFS signal, Load = 100 kOhm

**2:**  $f_{in} = 1$  kHz, B/W = 20 Hz to 20 kHz, A-weighted, -1 dBFS signal, Load = 16 Ohm

**3:**  $f_{in} = 1$  kHz, B/W = 20 Hz to 20 kHz, A-weighted, THD+N < 0.05%, 0 dBFS signal, Load = 16 Ohm

**4:** These parameters are characterized, but not tested in manufacturing.

**TABLE 8-7: TRANSMITTER SECTION FOR BDR AND EDR**

Parameter		Min.	Typ.	Max.	Bluetooth specification	Unit
RF transmit power	Class 1	—	15.0 <sup>(3)</sup>	—	< 20	dBm
	Class 2	—	2 <sup>(3)</sup>	—	-6 to 4	dBm
EDR/BDR Relative transmit power		-4	-1.8	1	-4 to 1	dB

**Note 1:** The RF Tx power is modulation value.

**2:** The RF Transmit power is calibrated during the production by using the MP tool software and MT8852 Bluetooth test equipment.

**3:** Test condition: VCC\_RF = 1.28V, temperature +25°C.



# BM62/64

**TABLE 8-8: RECEIVER SECTION FOR BDR AND EDR**

	Modulation	Min.	Typ.	Max.	Bluetooth specification	Unit
Sensitivity at 0.1% BER	GFSK	—	-89	—	≤-70	dBm
Sensitivity at 0.01% BER	π/4 DQPSK	—	-90	—	≤-70	dBm
	8 DPSK	—	-83	—	≤-70	dBm

**Note 1:** Test condition: VCC\_RF = 1.28V with temperature +25°C.

**2:** These parameters are characterized, but not tested in manufacturing.

**TABLE 8-9: BM62 SYSTEM CURRENT CONSUMPTION**

System Status	Typ. <sup>(1)</sup>	Max.	Unit
System-Off mode	—	10	μA
Stop advertising (Samsung S5 (SM-G900I)/Android™ 4.4.2)			
Standby mode	0.57	—	mA
Link mode	0.5	—	mA
ESCO link	15.1	—	mA
A2DP link	14.3	—	mA
Stop advertising (iPhone® 6/iOS 8.4)			
Standby mode	0.6	—	mA
Link mode	0.6	—	mA
SCO link	15.3	—	mA
A2DP link	15.4	—	mA

**Note 1:** The measurement data corresponds to Firmware v1.0.

**2:** Mode definition:

Standby mode: Power-on without Bluetooth link;

Link mode: With Bluetooth link in Low-power mode.

**3:** The current consumption values are measured with the BM62 EVB as test platform, with BAT\_IN = 3.8V. The distance between the smartphone and BM62 EVB is 30 cm, and the speaker is without loading.

**TABLE 8-10: BM64SPKS1MC2 EMBEDDED MODE (WITHOUT EXTERNAL MCU) SYSTEM CURRENT CONSUMPTION**

Mode/System Status	Typ. <sup>(1)</sup>	Max.	Unit
System-Off mode	1.61	—	μA
Standby mode	0.6	—	mA
Pairing mode	1.2	—	mA
Link mode	0.5	—	mA
SCO link	15.8	—	mA
A2DP link	14.5	—	mA

**Note 1:** The current consumption values are measured with the BM64 EVB (in standalone mode without MCU) as test platform, with BAT\_IN = 3.8V. The distance between the smartphone and BM64 EVB is 30 cm, and the speaker is without loading.

**2:** The measurement data corresponds to Firmware package: BM64 Software & Tools (DSPK v2.1), which is available in <https://www.microchip.com/wwwproducts/en/BM64>.

**3:** LED and Bluetooth Low Energy advertising is turned off in UI setting.

**4:** iPhone6+, iOS 11.4.

**TABLE 8-11: BM64SPKS1MC2 HOST MCU MODE SYSTEM CURRENT CONSUMPTION**

Mode/System Status	Typ. <sup>(1)</sup>	Max.	Unit
System-Off mode	15.23	—	μA
Standby mode	1.6	—	mA
Pairing mode	3.2	—	mA
Link mode	1.5	—	mA
SCO link	18.8	—	mA
A2DP link	17.5	—	mA

**Note 1:** The current consumption values are measured with the BM64 EVB (with MCU: PIC18F85J10) as test platform, with BAT\_IN = 3.3V. The distance between the smartphone and BM64 EVB is 30 cm, and the speaker is without loading.

**2:** Audio: I2S Digital Audio output to External Codec Yamaha YDA174.

**3:** The measurement data corresponds to Firmware package: BM64 Software & Tools (DSPK v2.1), which is available in <https://www.microchip.com/wwwproducts/en/BM64>.

**4:** Bluetooth Low Energy advertising is turned off.

## 8.1 Timing Specifications

Figure 8-1 and Figure 8-2 illustrate the timing diagram of the BM62/64 module in I<sup>2</sup>S and PCM modes.

**FIGURE 8-1: TIMING DIAGRAM FOR I<sup>2</sup>S MODES (HOST/CLIENT)**

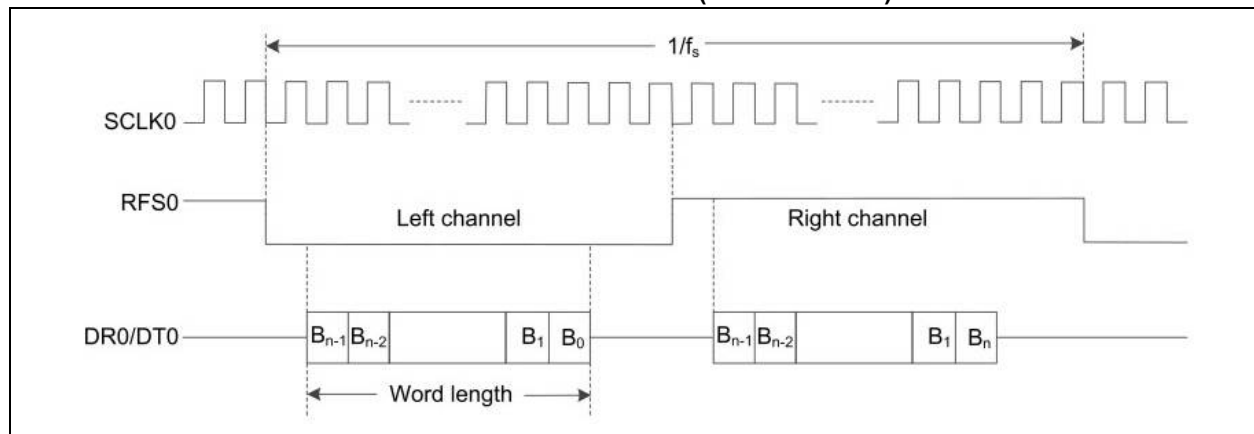

# BM62/64

**FIGURE 8-2: TIMING DIAGRAM FOR PCM MODES (HOST/CLIENT)**

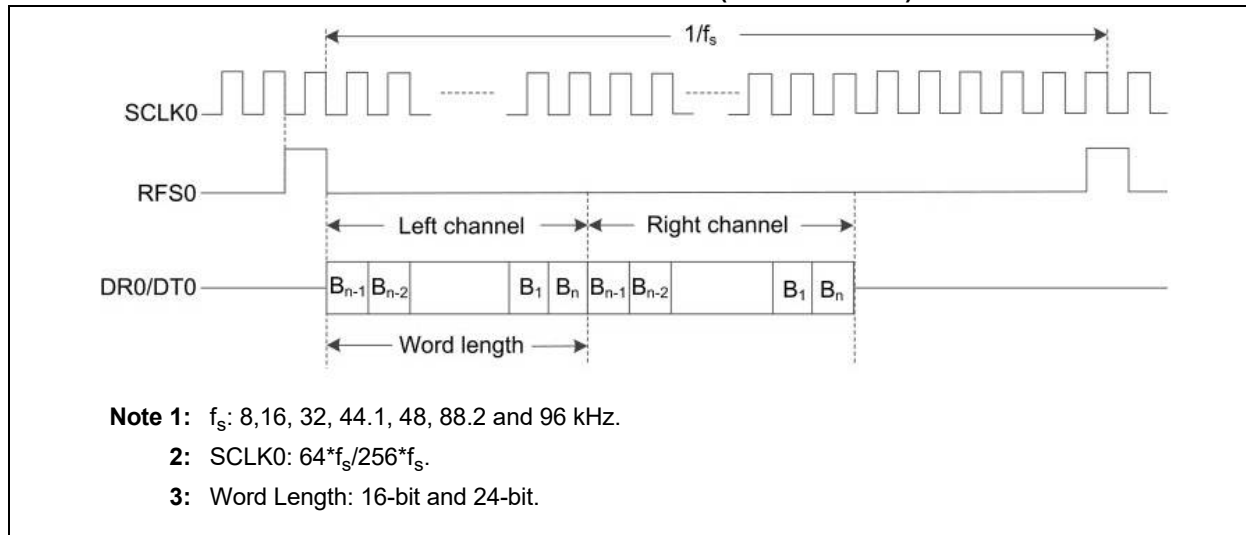

Figure 8-3 illustrates the timing diagram of the audio interface.

**FIGURE 8-3: AUDIO INTERFACE TIMING DIAGRAM**

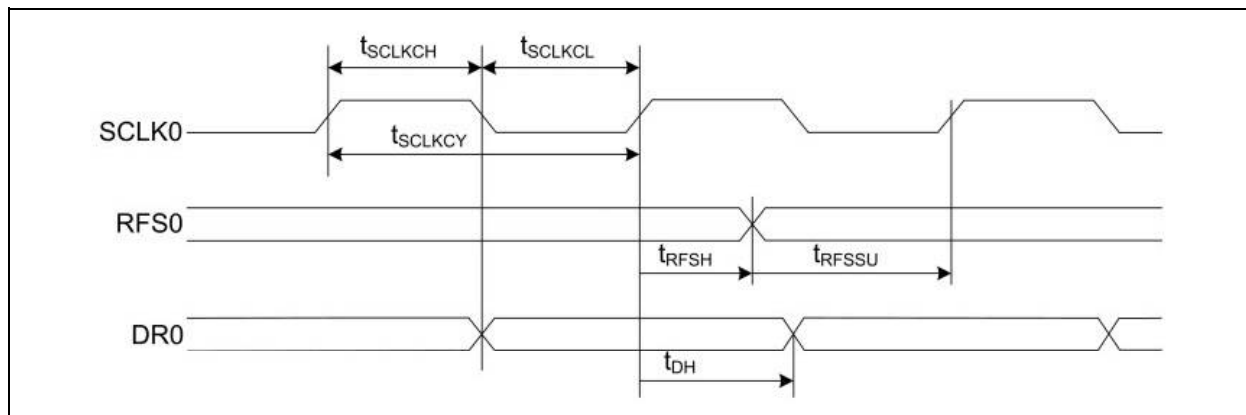

Table 8-12 provides the timing specifications of the audio interface.

**TABLE 8-12: AUDIO INTERFACE TIMING SPECIFICATIONS**

PARAMETER	SYMBOL	MIN	TYP	MAX	UNIT
SCLK0 duty ratio	$d_{SCLK}$	—	50	—	%
SCLK0 cycle time	$t_{SCLKCY}$	50	—	—	ns
SCLK0 pulse width high	$t_{SCLKCH}$	20	—	—	ns
SCLK0 pulse width low	$t_{SCLKCL}$	20	—	—	ns
RFS0 setup time to SCLK0 rising edge	$t_{RFSSU}$	10	—	—	ns
RFS0 hold time from SCLK0 rising edge	$t_{RFSH}$	10	—	—	ns
DR0 hold time from SCLK0 rising edge	$t_{DH}$	10	—	—	ns

**Note:** Test Conditions: Client mode,  $f_s = 48$  kHz, 24-bit data and SLK0 period =  $256 f_s$ .

NOTES:

# BM62/64

## 9.0 SOLDERING RECOMMENDATIONS

The BM62/64 module is assembled using a standard lead-free reflow profile, IPC/JEDEC J-STD-020. The BM62/64 module can be soldered to the main PCB using standard leaded and lead-free solder reflow profiles.

To avoid the damage to the module, follow these recommendations:

- Refer to Microchip Technology Application Note "AN233 Solder Reflow Recommendation" (DS00233) for the soldering reflow recommendations.

- Do not exceed peak temperature ( $T_P$ ) of +260°C.
- Refer to the "Solder Paste" data sheet for specific reflow profile recommendations.
- Use no-clean flux solder paste.
- Do not wash the module, as moisture can be trapped under the shield.
- Use only one flow. If the PCB requires multiple flows, apply the module on the final flow.

Figure 9-1 illustrates the reflow profile of the BM62/64 module.

FIGURE 9-1: REFLOW PROFILE

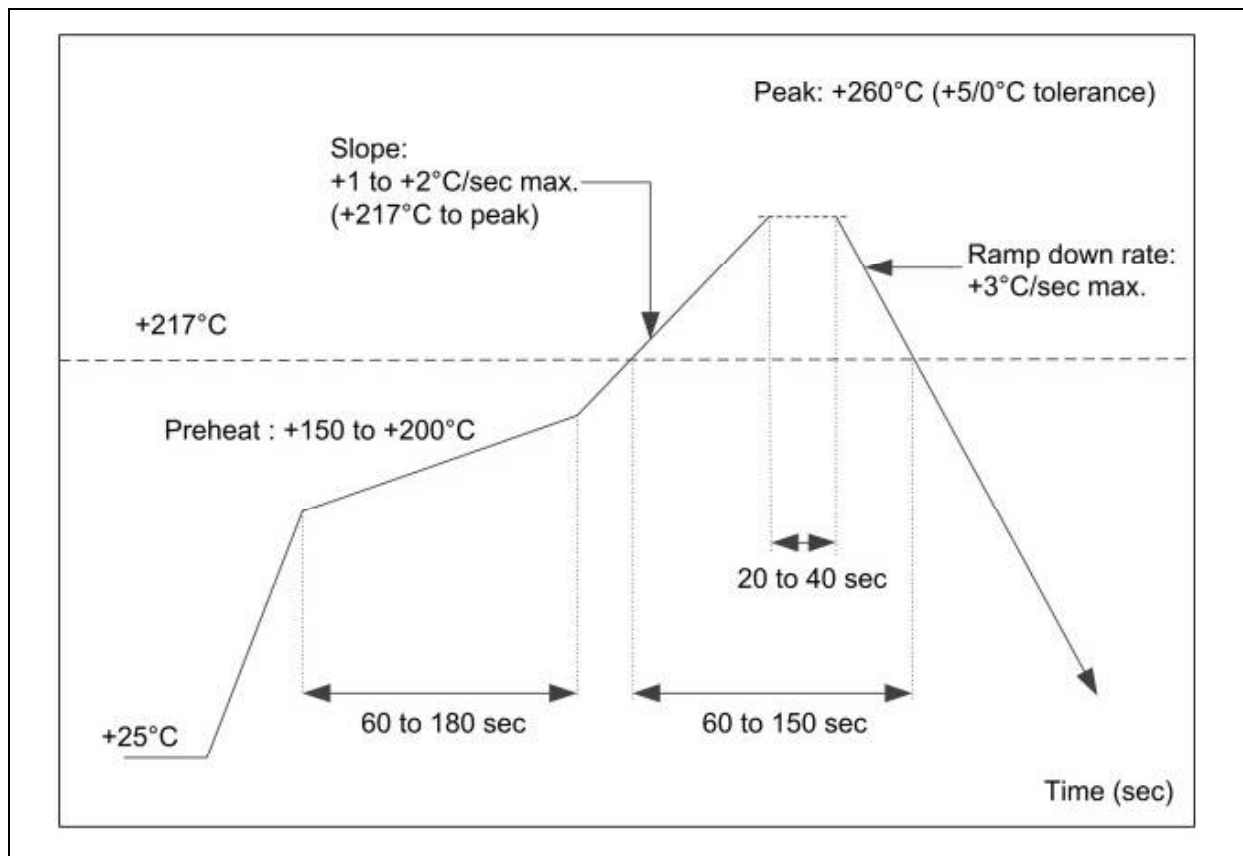

## 10.0 ORDERING INFORMATION

Table 10-1 provides ordering information for the BM62/64 module.

**TABLE 10-1: BM62/64 MODULE ORDERING INFORMATION**

Module	Microchip IC	Description	Shield	Regulatory Certification	Part No.
BM62	IS2062GM	Bluetooth 5.0 Stereo Audio module, Class 2 with RF shield	Yes	FCC, ISED, CE, MIC, KCC, NCC, SRRC	BM62SPKS1MC2
BM62	IS2062GM	Bluetooth 5.0 Stereo Audio module, Class 2 without RF shield	No	CE	BM62SPKA1MC2
BM64	IS2064GM	Bluetooth 5.0 Stereo Audio module, Class 2 with RF shield	Yes	FCC, ISED, CE, MIC, KCC, NCC, SRRC, ANATEL	BM64SPKS1MC2
BM64	IS2064GM	Bluetooth 5.0 Stereo Audio module, Class 2 without RF shield	No	CE	BM64SPKA1MC2
BM64	IS2064GM	Bluetooth 5.0 Stereo Audio module, Class 1 with RF shield	Yes	FCC, ISED, CE, MIC, KCC, NCC, SRRC, ANATEL	BM64SPKS1MC1
BM64	IS2064GM	Bluetooth 5.0 Stereo Audio module, Class 1 without RF shield	No	CE	BM64SPKA1MC1

**Note:** The BM62/64 module can be purchased through a Microchip representative. Visit [www.microchip.com](http://www.microchip.com) for the current pricing and a list of distributors for the product.

## APPENDIX A: CERTIFICATION NOTICES

The **BM62** module (BM62SPKS1MC2) has received regulatory approval for the following countries:

- BT SIG/QDID: 110148
- United States/FCC ID: A8TBM62S2
- Canada/ISED
  - IC: 12246A-BM62S2
  - HVIN: BM62SPKS1MC2
- Europe/CE
- Japan/MIC: 005-101204
- Korea/KCC: MSIP-CRM-mcp-BM62SPKS1MC2
- Taiwan/NCC No: CCAN16LP0270T5
- China/SRRC: CMIIT ID: 2016DJ2656

The **BM64C1 (Class 1)** module (BM64SPKS1MC1) has received regulatory approval for the following countries:

- BT SIG/QDID: 110159
- United States/FCC ID: A8TBM64S1
- Canada/ISED
  - IC: 12246A-BM64S1
  - HVIN: BM64SPKS1MC1
- Europe/CE
- Japan/MIC: 005-101206
- Korea/KCC: MSIP-CRM-mcp-BM64SPKS1MC1
- Taiwan/NCC No: CCAN16LP0300T1
- China/SRRC: CMIIT ID: 2016DJ2453
- Brazil/ANATEL: 05784-19-08759

The **BM64C2 (Class 2)** module (BM64SPKS1MC2) has received regulatory approval for the following countries:

- BT SIG/QDID: 110148
- United States/FCC ID: A8TBM64S2
- Canada/ISED
  - IC: 12246A-BM64S2
  - HVIN: BM64SPKS1MC2
- Europe/CE
- Japan/MIC: 005-101205
- Korea/KCC: MSIP-CRM-mcp-BM64SPKS1MC2
- Taiwan/NCC No: CCAN16LP0280T8
- China/SRRC: CMIIT ID: 2016DJ2356
- Brazil/ANATEL: 03822-18-08759

### A.1 REGULATORY APPROVAL

This section outlines the regulatory information of the BM62/BM64C1/BM64C2 Stereo Audio modules for the following countries:

- United States
- Canada
- Europe

- Japan
- Korea
- Taiwan
- China
- Brazil
- Other Regulatory Jurisdictions

#### A.1.1 UNITED STATES

The BM62/BM64C1/BM64C2 Stereo Audio module has received Federal Communications Commission (FCC) CFR47 Telecommunications, Part 15 Subpart C “Intentional Radiators” single-modular approval in accordance with Part 15.212 Modular Transmitter approval. Single-modular transmitter approval is defined as a complete RF transmission sub-assembly, designed to be incorporated into another device, that must demonstrate compliance with FCC rules and policies independent of any host. A transmitter with a modular grant can be installed in different end-use products (referred to as a host, host product, or host device) by the grantee or other equipment manufacturer, then the host product may not require additional testing or equipment authorization for the transmitter function provided by that specific module or limited module device.

The user must comply with all of the instructions provided by the Grantee, which indicate installation and/or operating conditions necessary for compliance.

The host product itself is required to comply with all other applicable FCC equipment authorizations regulations, requirements and equipment functions that are not associated with the transmitter module portion. For example, compliance must be demonstrated: to regulations for other transmitter components within a host product; to requirements for unintentional radiators (Part 15 Subpart B), such as digital devices, computer peripherals, radio receivers, etc.; and to additional authorization requirements for the non-transmitter functions on the transmitter module (i.e., Verification, or Declaration of Conformity) as appropriate (e.g., Bluetooth and Wi-Fi transmitter modules may also contain digital logic functions).

#### A.1.2 LABELING AND USER INFORMATION REQUIREMENTS

The BM62/BM64C1/BM64C2 Stereo Audio module has been labeled with its own FCC ID number, and if the FCC ID is not visible when the module is installed inside another device, then the outside of the finished product into which the module is installed must also display a label referring to the enclosed module. This exterior label can use wording as follows:

For the BM62:

Contains Transmitter Module FCC ID: A8TBM62S2

or

Contains FCC ID: A8TBM62S2

**This device complies with Part 15 of the FCC Rules. Operation is subject to the following two conditions: (1) this device may not cause harmful interference, and (2) this device must accept any interference received, including interference that may cause undesired operation**

For the BM64C1:

Contains Transmitter Module FCC ID: A8TBM64S1

or

Contains FCC ID: A8TBM64S1

**This device complies with Part 15 of the FCC Rules. Operation is subject to the following two conditions: (1) this device may not cause harmful interference, and (2) this device must accept any interference received, including interference that may cause undesired operation**

For the BM64C2:

Contains Transmitter Module FCC ID: A8TBM64S2

or

Contains FCC ID: A8TBM64S2

**This device complies with Part 15 of the FCC Rules. Operation is subject to the following two conditions: (1) this device may not cause harmful interference, and (2) this device must accept any interference received, including interference that may cause undesired operation**

A user's manual for the product must include the following statement:

This equipment has been tested and found to comply with the limits for a Class B digital device, pursuant to part 15 of the FCC Rules. These limits are designed to provide reasonable protection against harmful interference in a residential installation. This equipment generates, uses and can radiate radio frequency energy, and if not installed and used in accordance with the instructions, may cause harmful interference to radio communications. However, there is no guarantee that interference will not occur in a particular installation. If this equipment does cause harmful interference to radio or television reception, which can be determined by turning the equipment off and on, the user is encouraged to try to correct the interference by one or more of the following measures:

- Reorient or relocate the receiving antenna
- Increase the separation between the equipment and receiver
- Connect the equipment into an outlet on a circuit different from that to which the receiver is connected
- Consult the dealer or an experienced radio/TV technician for help

Additional information on labeling and user information requirements for Part 15 devices can be found in KDB Publication 784748, which is available at the FCC Office of Engineering and Technology (OET) Laboratory Division Knowledge Database (KDB) <https://apps.fcc.gov/oetcf/kdb/index.cfm>

### A.1.3 RF EXPOSURE

All transmitters regulated by FCC must comply with RF exposure requirements. KDB 447498 General RF Exposure Guidance provides guidance in determining whether proposed or existing transmitting facilities, operations or devices comply with limits for human exposure to Radio Frequency (RF) fields adopted by the Federal Communications Commission (FCC).

From the FCC Grant: Output power listed is conducted. This grant is valid only when the module is sold to OEM integrators and must be installed by the OEM or OEM integrators. This transmitter is restricted for use with the specific antenna(s) tested in this application for Certification and must not be co-located or operating in conjunction with any other antenna or transmitters within a host device, except in accordance with FCC multi-transmitter product procedures.

BM62 and BM64C2: These modules are approved for installation into mobile or/and portable host platforms.

BM64C1: The installation of the transmitter must ensure that the antenna has a separation distance of at least 30 mm from all persons or compliance, and it must be demonstrated according to the FCC SAR procedures.



# BM62/64

## A.1.4 APPROVED ANTENNAS

To maintain modular approval in the United States, only the antenna types that have been tested shall be used. It is permissible to use different antenna, provided the same antenna type, antenna gain (equal to or less than), with similar in-band and out-of band characteristics (refer to specification sheet for cutoff frequencies).

For BM62/BM64C1/BM64C2, the approval is received using the antenna listed in [Table 6-1](#).

## A.1.5 HELPFUL WEB SITES

Federal Communications Commission (FCC):  
<https://www.fcc.gov/>

FCC Office of Engineering and Technology (OET) Laboratory Division Knowledge Database (KDB):  
<https://apps.fcc.gov/oetcf/kdb/index.cfm>

## A.2 Canada

The BM62/BM64C1/BM64C2 Stereo Audio module has been certified for use in Canada under Innovation, Science and Economic Development Canada (ISED, formerly Industry Canada) Radio Standards Procedure (RSP) RSP-100, Radio Standards Specification (RSS) RSS-Gen and RSS-247. Modular approval permits the installation of a module in a host device without the need to rectify the device.

### A.2.1 LABELING AND USER INFORMATION REQUIREMENTS

Labeling Requirements (from RSP-100, Issue 12, Section 5): The host product shall be properly labeled to identify the module within the host device.

The Innovation, Science and Economic Development Canada certification label of a module shall be clearly visible at all times when installed in the host product, otherwise the host device must be labeled to display the Innovation, Science and Economic Development Canada certification number of the module, preceded by the word "Contains", or similar word expressing the same meaning, as follows:

For the BM62:

Contains IC: 12246A-BM62S2

For the BM64C1:

Contains IC: 12246A-BM64S1

For the BM64C2:

Contains IC: 12246A-BM64S2

User Manual Notice for License-Exempt Radio Apparatus (from Section 8.4 RSS-Gen, Issue 5, March 2019): User manuals for license-exempt radio apparatus shall

contain the following or equivalent notice in a conspicuous location in the user manual or alternatively on the device or both:

**This device contains license-exempt transmitters/receiver(s) that comply with Innovation, Science and Economic Development Canada's license-exempt RSS (s). Operation is subject to the following two conditions:**

- This device may not cause interference;
- This device must accept any interference, including interference that may cause undesired operation of the device.

**L'émetteur/récepteur exempt de licence contenu dans le présent appareil est conforme aux CNR d'Innovation, Sciences et Développement**

**économique Canada applicables aux appareils radio exempts de licence. L'exploitation est autorisée aux deux conditions suivantes:**

- L'appareil ne doit pas produire de brouillage;
- L'appareil doit accepter tout brouillage radioélectrique subi, même si le brouillage est susceptible d'en compromettre le fonctionnement.

Transmitter Antenna (From Section 6.8 RSS-GEN, Issue 5, March 2019): User manuals, for transmitters shall display the following notice in a conspicuous location:

**This radio transmitter [IC: 12246A-BM62S2, IC: 12246A-BM64S1 and IC: 12246A-BM64S2] has been approved by Innovation, Science and Economic Development Canada to operate with the antenna types listed below, with the maximum permissible gain indicated. Antenna types not included in this list that have a gain greater than the maximum gain indicated for any type listed are strictly prohibited for use with this device.**

**Le présent émetteur radio**

**[IC: 12246A-BM62S2, IC: 12246A-BM64S1 and IC: 12246A-BM64S2] a été approuvé par Innovation, Sciences et Développement économique Canada pour fonctionner avec les types**

**d'antenne énumérés cidessous et ayant un gain admissible maximal. Les types d'antenne non inclus dans cette liste, et dont le gain est supérieur au gain maximal indiqué pour tout type figurant sur la liste, sont strictement interdits pour l'exploitation de l'émetteur.**

Immediately following the above notice, the manufacturer shall provide a list of all antenna types approved for use with the transmitter, indicating the maximum permissible antenna gain (in dBi) and required impedance for each.

## A.2.2 RF EXPOSURE

All transmitters regulated by the Innovation, Science and Economic Development Canada (ISED) must comply with RF exposure requirements listed in RSS-102 - Radio Frequency (RF) Exposure Compliance of Radio communication Apparatus (All Frequency Bands).

This transmitter is restricted for use with a specific antenna tested in this application for certification, and must not be co-located or operating in conjunction with any other antenna or transmitters, except in accordance with Innovation, Science and Economic Development Canada multi-transmitter guidelines.

BM62 and BM64C2: The device operates at an output power level which is within the ISED SAR test exemption limits at any user distance.

BM64C1: The installation of the transmitter must ensure that the antenna has a separation distance of at least 30 mm from all persons or compliance must be demonstrated according to the ISED SAR procedures.

## A.2.3 APPROVED ANTENNAS

For BM62/BM64C1/BM64C2, the approval is received using the antenna listed in [Table 6-1](#).

## A.2.4 HELPFUL WEBSITES

Innovation, Science and Economic Development Canada (ISED): <http://www.ic.gc.ca/>

## A.3 Europe

The BM62/BM64C1/BM64C2 module is Radio Equipment Directive (RED) assessed, CE marked, and have been manufactured and tested with the intention of being integrated into a final product.

The BM62/BM64C1/BM64C2 module has been tested to RED 2014/53/EU Essential Requirements mentioned in the following European Compliance table.

**TABLE A-1: EUROPEAN COMPLIANCE**

Certification	Standards	Article
Safety	EN 62368	3.1a
Health	EN 62311	
Electro Magnetic Compatibility (EMC)	EN 301 489-1	3.1b
	EN 301 489-17	
Radio	EN 300 328	3.2

The ETSI provides guidance on modular devices in "Guide to the application of harmonized standards covering Article 3.1(b) and Article 3.2 of the Directive 2014/53/EU RED to multi-radio and combined radio and non-radio equipment" document available at [http://www.etsi.org/deliver/etsi\\_eg/203300\\_203399/203367/01.01.01\\_60/eg\\_203367v010101p.pdf](http://www.etsi.org/deliver/etsi_eg/203300_203399/203367/01.01.01_60/eg_203367v010101p.pdf)

**Note:** To maintain conformance to the testing listed in [Table A-1](#), the module shall be installed in accordance with the installation instructions in this data sheet and shall not be modified. When integrating a radio module into a completed product the integrator becomes the manufacturer of the final product and is therefore responsible for demonstrating compliance of the final product with the essential requirements against RED.

## A.3.1 LABELING AND USER INFORMATION REQUIREMENTS

The label on the final product which contains the BM62/BM64C1/BM64C2 module must follow CE marking requirements

## A.3.2 CONFORMITY ASSESSMENT

From ETSI Guidance Note EG 203367, section 6.1 Non-radio products are combined with a radio product:

If the manufacturer of the combined equipment installs the radio product in a host non-radio product in equivalent assessment conditions (host equivalent to the one used for the assessment of the radio product) and according to the installation instructions for the radio product, then no additional assessment of the combined equipment against article 3.2 of the RED is required.

### A.3.2.1 SIMPLIFIED EU DECLARATION OF CONFORMITY

Hereby, Microchip Technology Inc. declares that the radio equipment type BM62/BM64C1/BM64C2 is in compliance with Directive 2014/53/EU.

The full text of the EU declaration of conformity, for this product, is available at

<https://www.microchip.com/wwwproducts/en/bm70>

<https://www.microchip.com/wwwproducts/en/BM71>

(available under Documents > Certifications).

## A.3.3 APPROVED ANTENNAS

For BM62/BM64C1/BM64C2, the approval is received using the integral PCB antenna listed in [Table 6-1](#).

## A.3.4 HELPFUL WEB SITES

A document that can be used as a starting point in understanding the use of Short Range Devices (SRD) in Europe is the European Radio Communications Committee (ERC) Recommendation 70-03 E, which can be downloaded from the European Radio Communications Office (ERO) at: <http://www.ero.dk/>.

Additional helpful web sites are:

# BM62/64

- Radio Equipment Directive (2014/53/EU): <https://ec.europa.eu/growth/single-market/euro>
- European Conference of Postal and Telecommunications Administrations (CEPT): <http://www.cept.org/>
- European Telecommunications Standards Institute (ETSI): <http://www.etsi.org>

The Radio Equipment Directive Compliance Association (REDCA): <http://www.redca.eu/>

## A.4 Japan

The BM62/BM64C1/BM64C2 Stereo Audio module has received type certification and is labeled with its own technical conformity mark and certification number as required to conform to the technical standards regulated by the Ministry of Internal Affairs and Communications (MIC) of Japan pursuant to the Radio Act of Japan.

Integration of this module into a final product does not require additional radio certification provided installation instructions are followed and no modifications of the module are allowed. Additional testing may be required:

- If the host product is subject to electrical appliance safety (for example, powered from an AC mains), the host product may require Product Safety Electrical Appliance and Material (PSE) testing. The integrator must contact their conformance laboratory to determine if this testing is required
- There is an voluntary Electromagnetic Compatibility (EMC) test for the host product administered by VCCI: [http://www.vcci.jp/vcci\\_e/index.html](http://www.vcci.jp/vcci_e/index.html)

### A.4.1 LABELING AND USER INFORMATION REQUIREMENTS

The label on the final product which contains the BM62/BM64C1/BM64C2 Stereo Audio module must follow Japan marking requirements. The integrator of the module must refer to the labeling requirements for Japan available at the Ministry of Internal Affairs and Communications (MIC) website.

For the BM62 Stereo Audio module, due to a limited module size, the technical conformity logo and ID is displayed in the data sheet and/or packaging and cannot be displayed on the module label. The final product in which this module is being used must have a label referring to the type certified module inside:



For the BM64C1 Stereo Audio module, due to limited module size, the technical conformity logo and ID is displayed in the data sheet and/or packaging and cannot be displayed on the module label. The final product in which this module is being used must have a label referring to the type certified module inside:

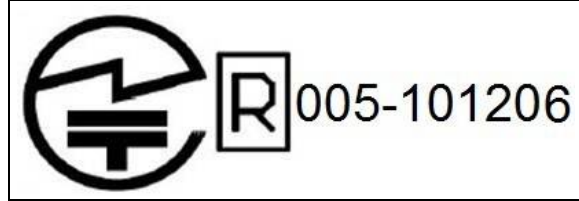

For the BM64C2 Stereo Audio module, due to limited module size, the technical conformity logo and ID is displayed in the data sheet and/or packaging and cannot be displayed on the module label. The final product in which this module is being used must have a label referring to the type certified module inside:

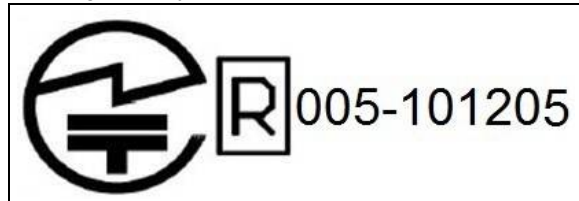

### A.4.2 HELPFUL WEB SITES

Ministry of Internal Affairs and Communications (MIC): <http://www.tele.soumu.go.jp/e/index.htm>

Association of Radio Industries and Businesses (ARIB): <http://www.arib.or.jp/english/>

## A.5 Korea

The BM62/BM64C1/BM64C2 Stereo Audio module has received certification of conformity in accordance with the Radio Waves Act. Integration of this module into a final product does not require additional radio certification provided installation instructions are followed and no modifications of the module are allowed.

### A.5.1 LABELING AND USER INFORMATION REQUIREMENTS

The label on the final product which contains the BM62/BM64C1/BM64C2 Stereo Audio module must follow KC marking requirements. The integrator of the module must refer to the labeling requirements for Korea available on the Korea Communications Commission (KCC) website.

The BM62 Stereo Audio module is labeled with its own KC mark. The final product requires the KC mark and certificate number of the module:

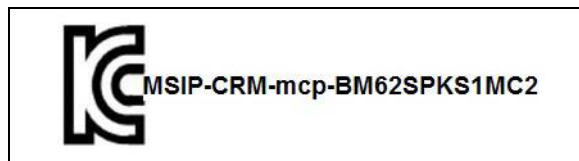

The BM64C1 Stereo Audio module is labeled with its own KC mark. The final product requires the KC mark and certificate number of the module:

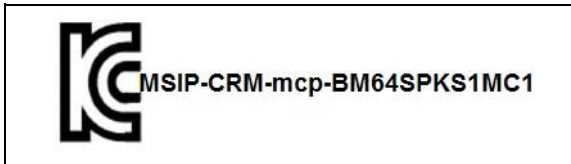

The BM64C2 Stereo Audio module is labeled with its own KC mark. The final product requires the KC mark and certificate number of the module:

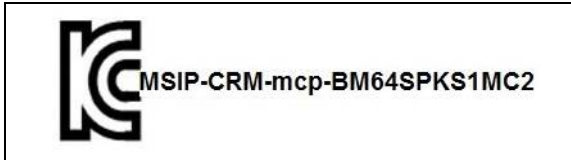

## A.5.2 HELPFUL WEB SITES

Korea Communications Commission (KCC):  
<http://www.kcc.go.kr>

National Radio Research Agency (RRA):  
<http://rra.go.kr>

## A.6 Taiwan

The BM62/BM64C1/BM64C2 Stereo Audio module has received compliance approval in accordance with the Telecommunications Act. Customers seeking to use the compliance approval in their product must contact Microchip Technology sales or distribution partners to obtain a Letter of Authority.

Integration of this module into a final product does not require additional radio certification provided installation instructions are followed and no modifications of the module are allowed.

### A.6.1 LABELING AND USER INFORMATION REQUIREMENTS

For the BM62 Stereo Audio module, due to limited module size, the NCC mark and ID are displayed in the data sheet and/or packaging and cannot be displayed on the module label.



For the BM64C1 Stereo Audio module, due to limited module size, the NCC Mark and ID are displayed in the data sheet and/or packaging and cannot be displayed on the module label.



For the BM64C2 Stereo Audio module, due to limited module size, the NCC Mark and ID is displayed in the data sheet and/or packaging and cannot be displayed on the module label.



The user's manual must contain below warning (for RF device) in traditional Chinese:

注意！

依據 低功率電波輻射性電機管理？法

第十二條 經型式認證合格之低功率射頻電機，非經許可，

公司、商號或使用者均不得擅自變更頻率、加大功率或變更原設計

之特性及功能。

第十四條 低功率射頻電機之使用不得影響飛航安全及干擾合法通信；

經發現有干擾現象時，應立即停用，並改善至無干擾時方得繼續使用。

前項合法通信，指依電信規定作業之無線電信。

低功率射頻電機須忍受合法通信或工業、科學及醫療用電波輻射性

電機設備之干擾。

### A.6.2 HELPFUL WEB SITES

National Communications Commission (NCC):  
<http://www.ncc.gov.tw>

## A.7 China

The BM62/BM64C1/BM64C2 Stereo Audio module has received certification of conformity in accordance with the China MIIT Notice 2014-01 of State Radio Regulation Committee (SRRC) certification scheme. Integration of this module into a final product does not require additional radio certification, provided installation instructions are followed and no modifications of the module are allowed. Refer to SRRC certificate available in the BM62/BM64C1/BM64C2 product page for expiry date.

## A.7.1 LABELING AND USER INFORMATION REQUIREMENTS

The BM62 Stereo Audio module is labeled with its own CMIIT ID as follows:

**CMIIT ID: 2016DJ2656**

When Host system is using an approved Full Modular Approval (FMA) radio: The host must bear a label containing the statement "This device contains SRRC approved Radio module CMIIT ID 2016DJ2656".

The BM64C1 Stereo Audio module is labeled with its own CMIIT ID as follows:

**CMIIT ID: 2016DJ2453**

When Host system is using an approved Full Modular Approval (FMA) radio: The host must bear a label containing the statement "This device contains SRRC approved Radio module CMIIT ID 2016DJ2453".

The BM64C2 Stereo Audio module is labeled with its own CMIIT ID as follows:

**CMIIT ID: 2016DJ2356**

When Host system is using an approved Full Modular Approval (FMA) radio: The host must bear a label containing the statement "This device contains SRRC approved Radio module CMIIT ID 2016DJ2356".

## A.8 Brazil

The BM64SPKS1MC1/BM64SPKS1MC2 Stereo Audio module has received compliance approval in accordance with the Telecommunications Act of the

Federal Republic of Brazil National Telecommunications Agency (ANATEL). Customers seeking to use the compliance approval in their product must contact Microchip Technology sales or distribution partners to obtain a Letter of Authority.

Integration of this module into a final product does not require additional radio certification provided installation instructions are followed and no modifications of the module are allowed.

## A.8.1 LABELING AND USER INFORMATION REQUIREMENTS

"Este produto esta homologado pela ANATEL, de acordo com os procedimentos regulamentados pela Resolucao 242/2000, e atende aos requisitos tecnicos aplicados".

Para maiores informacoes, consulte o site da ANATEL: [www.anatel.gov.br](http://www.anatel.gov.br)

For Homologation Validity refer to the Certification and Approval Management System - SCH, available on [www.anatel.gov.br](http://www.anatel.gov.br)

Modelo: BM64SPKS1MC1



**05784-19-08759**

"Este equipamento não tem direito à proteção contra interferência prejudicial e não pode causar interferência em sistemas devidamente autorizados".

Modelo: BM64SPKS1MC2



**03822-18-08759**

"Este equipamento não tem direito à proteção contra interferência prejudicial e não pode causar interferência em sistemas devidamente autorizados".

The End product (Host) manual must include the following statement:

For BM64SPKS1MC1:

Este producto contém a placa Modelo BM64SPKS1MC1 código de homologação ANATEL 05784-19-08759.

For BM64SPKS1MC2:

Este producto contém a placa Modelo BM64SPKS1MC2 código de homologação ANATEL 03822-18-08759.

## A.9 Other Regulatory Jurisdictions

- For information on the other countries jurisdictions covered, refer to the <http://www.microchip.com/design-centers/wireless-connectivity/certifications>.
- Should other regulatory jurisdiction certification be required by the customer, or the customer need to recertify the module for other reasons, contact Microchip for the required utilities and documentation.

# BM62/64

## APPENDIX B: REVISION HISTORY

### Revision A (May 2016)

This is the initial released version of this document.

### Revision B (December 2016)

This revision includes the following changes and minor updates to text and formatting, which were incorporated throughout the document.

**TABLE B-1: MAJOR SECTION UPDATES**

Section	Update Description
<a href="#">“Audio Codec”</a>	Updated the I <sup>2</sup> S digital audio applicability and SNR details of 20-bit DAC and 16-bit ADC.
<a href="#">“Compliance”</a>	Updated the certification information.
<a href="#">1.0“Device Overview”</a>	Added USB and BLE and updated the Customized voice prompt details in <a href="#">Table 1-1</a> . Updated <a href="#">Figure 1-4</a> and <a href="#">Table 1-2</a> with correct pin names for pins 11 and 12. Deleted the ROM details and updated <a href="#">Table 1-2</a> , <a href="#">Table 1-3</a> .
<a href="#">2.2“Codec”</a>	Added a note for internal codec support and addition of trailing zeros.
<a href="#">5.0“Application Information”</a>	Updated <a href="#">Figure 5-19</a> and <a href="#">Figure 5-21</a> .
<a href="#">8.0“Electrical Characteristics”</a>	Added the storage temperature details.
<a href="#">10.0“Ordering Information”</a>	Updated <a href="#">Table 10-1</a> with regulatory certification information.
<a href="#">Appendix A:“Certification Notices”</a>	Added Certification IDs and updated associated sections.

### Revision C (October 2017)

This revision includes the following changes and minor updates to text and formatting, which were incorporated throughout the document.

**TABLE C-1: MAJOR SECTION UPDATES**

Section	Update Description
<a href="#">“Compliance”</a>	Added Brazil certification information. Updated Canada certification information.
<a href="#">1.0“Device Overview”</a>	Updated <a href="#">Figure 1-1</a> , <a href="#">Figure 1-2</a> , and <a href="#">Figure 1-5</a> . Deleted <a href="#">Figure 1-3</a> and <a href="#">Figure 1-4</a> . Updated <a href="#">Table 1-1</a> . Updated pin description for pins ADAP_IN, BAT_IN and SYS_PWR in <a href="#">Table 1-2</a> and <a href="#">Table 1-3</a> .
<a href="#">10.0“Ordering Information”</a>	Updated <a href="#">Table 10-1</a> with Brazil and Canada regulatory certification information.
<a href="#">Appendix A:“Certification Notices”</a>	Updated the United States, Canada and Europe certification information. Updated KDB and ECC URL links. Added Brazil regulatory certification details.

## Revision D (March 2018)

This revision includes the following changes and minor updates to text and formatting, which were incorporated throughout the document.

**TABLE D-1: MAJOR SECTION UPDATES**

Section	Update Description
<a href="#">1.0“Device Overview”</a>	Updated pin type for LED pins in <a href="#">Table 1-2</a> and <a href="#">Table 1-3</a>
<a href="#">4.4“Under Voltage Protection (Software Dependent UVP)”</a>	Updated the section
<a href="#">5.0“Application Information”</a>	Added <a href="#">5.1 “Power Supply”</a> , <a href="#">5.2.1 “Device FW Upgrade (DFU)”</a> and <a href="#">5.2.1.1 “Enter BT Module/MCU DFU mode”</a> . Added <a href="#">Figure 5-1</a> , <a href="#">Figure 5-9</a> and <a href="#">Figure 5-10</a> . Updated <a href="#">Figure 5-4</a> , <a href="#">Figure 5-8</a> , <a href="#">Figure 5-20</a> and <a href="#">Table 5-1</a> .
<a href="#">8.0“Electrical Characteristics”</a>	Updated <a href="#">Table 8-2</a> .

## Revision E (September 2018)

This revision includes the following changes, which were incorporated throughout the document.

**TABLE E-1: MAJOR SECTION UPDATES**

Section	Update Description
Document	Updated Bluetooth version 4.2 to 5.0
<a href="#">A.8“Brazil”</a>	Updated with the certification for BM64SPKS1MC2 module
<a href="#">Figure 5-8</a>	<ul style="list-style-type: none"> <li>Updated with 2.7V information in figure.</li> <li>Updated figure footnotes.</li> </ul>

## Revision F (June 2020)

This revision includes the following changes, which were incorporated throughout the document.

**TABLE F-1: MAJOR SECTION UPDATES**

Section	Update Description
<a href="#">8.0 “Electrical Characteristics”</a>	Added <a href="#">Table 8-10</a> and <a href="#">Table 8-11</a> .
<a href="#">A.8“Brazil”</a>	Updated with the BM64SPKS1MC1 module certification details.



# BM62/64

## Revision G (April 2021)

This revision includes the following changes, which were incorporated throughout the document.

**TABLE G-1: MAJOR SECTION UPDATES**

Section	Update Description
<a href="#">1.0 “Device Overview”</a>	Updated <a href="#">Table 1-3</a> with the new terminologies. For more details, see the below note
<a href="#">5.3 “I2S Mode Application”</a>	Updated with the new terminologies. For more details, see the below note
<a href="#">8.1 “Timing Specifications”</a>	Updated with the new terminologies. For more details, see the below note
<a href="#">Appendix A: “Certification Notices”</a>	<ul style="list-style-type: none"><li>• Updated content</li><li>• Added <a href="#">A.1.4 “Approved Antennas”</a></li><li>• Added <a href="#">A.2.3 “Approved Antennas”</a></li><li>• Updated <a href="#">A.3 “Europe”</a></li></ul>

**Note 1:** *Microchip is aware that some terminologies used in the technical documents and existing software codes of this product are outdated and unsuitable. This document may use these new terminologies, which may or may not reflect on the source codes, software GUIs, and the documents referenced within this document. The following table shows the relevant terminology changes made in this document*

**TABLE 1: TERMINOLOGY RELATED CHANGES**

Old Terminology	New Terminology	
Master	Central	<a href="#">1.0 “Device Overview”</a> is updated with the new terminology
Slave	Peripheral	
I <sup>2</sup> S Master	I <sup>2</sup> S Host	<a href="#">5.3 “I2S Mode Application”</a> is updated with the new terminology
I <sup>2</sup> S Slave	I <sup>2</sup> S Client	
I <sup>2</sup> S Master	I <sup>2</sup> S Host	<a href="#">8.1 “Timing Specifications”</a> is updated with the new terminology
I <sup>2</sup> S Slave	I <sup>2</sup> S Client	



---

---

**Note the following details of the code protection feature on Microchip devices:**

- Microchip products meet the specifications contained in their particular Microchip Data Sheet.
- Microchip believes that its family of products is secure when used in the intended manner and under normal conditions.
- There are dishonest and possibly illegal methods being used in attempts to breach the code protection features of the Microchip devices. We believe that these methods require using the Microchip products in a manner outside the operating specifications contained in Microchip's Data Sheets. Attempts to breach these code protection features, most likely, cannot be accomplished without violating Microchip's intellectual property rights.
- Microchip is willing to work with any customer who is concerned about the integrity of its code.
- Neither Microchip nor any other semiconductor manufacturer can guarantee the security of its code. Code protection does not mean that we are guaranteeing the product is "unbreakable." Code protection is constantly evolving. We at Microchip are committed to continuously improving the code protection features of our products. Attempts to break Microchip's code protection feature may be a violation of the Digital Millennium Copyright Act. If such acts allow unauthorized access to your software or other copyrighted work, you may have a right to sue for relief under that Act.

---

Information contained in this publication is provided for the sole purpose of designing with and using Microchip products. Information regarding device applications and the like is provided only for your convenience and may be superseded by updates. It is your responsibility to ensure that your application meets with your specifications.

THIS INFORMATION IS PROVIDED BY MICROCHIP "AS IS". MICROCHIP MAKES NO REPRESENTATIONS OR WARRANTIES OF ANY KIND WHETHER EXPRESS OR IMPLIED, WRITTEN OR ORAL, STATUTORY OR OTHERWISE, RELATED TO THE INFORMATION INCLUDING BUT NOT LIMITED TO ANY IMPLIED WARRANTIES OF NON-INFRINGEMENT, MERCHANTABILITY, AND FITNESS FOR A PARTICULAR PURPOSE OR WARRANTIES RELATED TO ITS CONDITION, QUALITY, OR PERFORMANCE.

IN NO EVENT WILL MICROCHIP BE LIABLE FOR ANY INDIRECT, SPECIAL, PUNITIVE, INCIDENTAL OR CONSEQUENTIAL LOSS, DAMAGE, COST OR EXPENSE OF ANY KIND WHATSOEVER RELATED TO THE INFORMATION OR ITS USE, HOWEVER CAUSED, EVEN IF MICROCHIP HAS BEEN ADVISED OF THE POSSIBILITY OR THE DAMAGES ARE FORESEEABLE. TO THE FULLEST EXTENT ALLOWED BY LAW, MICROCHIP'S TOTAL LIABILITY ON ALL CLAIMS IN ANY WAY RELATED TO THE INFORMATION OR ITS USE WILL NOT EXCEED THE AMOUNT OF FEES, IF ANY, THAT YOU HAVE PAID DIRECTLY TO MICROCHIP FOR THE INFORMATION. Use of Microchip devices in life support and/or safety applications is entirely at the buyer's risk, and the buyer agrees to defend, indemnify and hold harmless Microchip from any and all damages, claims, suits, or expenses resulting from such use. No licenses are conveyed, implicitly or otherwise, under any Microchip intellectual property rights unless otherwise stated.

### Trademarks

The Microchip name and logo, the Microchip logo, Adaptec, AnyRate, AVR, AVR logo, AVR Freaks, BesTime, BitCloud, chipKIT, chipKIT logo, CryptoMemory, CryptoRF, dsPIC, FlashFlex, flexPWR, HELDO, IGL00, JukeBlox, KeeLoq, Klear, LANCheck, LinkMD, maXStylus, maXTouch, MediaLB, megaAVR, Microsemi, Microsemi logo, MOST, MOST logo, MPLAB, OptoLyzer, PackeTime, PIC, picoPower, PICSTART, PIC32 logo, PolarFire, Prochip Designer, QTouch, SAM-BA, SenGenuity, SpyNIC, SST, SST Logo, SuperFlash, Symmetricom, SyncServer, Tachyon, TimeSource, tinyAVR, UNI/O, Vectron, and XMEGA are registered trademarks of Microchip Technology Incorporated in the U.S.A. and other countries.

AgileSwitch, APT, ClockWorks, The Embedded Control Solutions Company, EtherSynch, FlashTec, Hyper Speed Control, HyperLight Load, IntelliMOS, Libero, motorBench, mTouch, Powermite 3, Precision Edge, ProASIC, ProASIC Plus, ProASIC Plus logo, Quiet-Wire, SmartFusion, SyncWorld, Temux, TimeCesium, TimeHub, TimePictra, TimeProvider, WinPath, and ZL are registered trademarks of Microchip Technology Incorporated in the U.S.A.

Adjacent Key Suppression, AKS, Analog-for-the-Digital Age, Any Capacitor, AnyIn, AnyOut, Augmented Switching, BlueSky, BodyCom, CodeGuard, CryptoAuthentication, CryptoAutomotive, CryptoCompanion, CryptoController, dsPICDEM, dsPICDEM.net, Dynamic Average Matching, DAM, ECAN, Espresso T1S, EtherGREEN, IdealBridge, In-Circuit Serial Programming, ICSP, INICnet, Intelligent Paralleling, Inter-Chip Connectivity, JitterBlocker, maxCrypto, maxView, memBrain, Mindi, MiWi, MPASM, MPF, MPLAB Certified logo, MPLIB, MPLINK, MultiTRAK, NetDetach, Omniscient Code Generation, PICDEM, PICDEM.net, PICkit, PICtail, PowerSmart, PureSilicon, QMatrix, REAL ICE, Ripple Blocker, RTAX, RTG4, SAM-ICE, Serial Quad I/O, simpleMAP, SimpliPHY, SmartBuffer, SMART-I.S., storClad, SQI, SuperSwitcher, SuperSwitcher II, Switchtec, SynchroPHY, Total Endurance, TSHARC, USBCheck, VariSense, VectorBlox, VeriPHY, ViewSpan, WiperLock, XpressConnect, and ZENA are trademarks of Microchip Technology Incorporated in the U.S.A. and other countries.

SQTP is a service mark of Microchip Technology Incorporated in the U.S.A.

The Adaptec logo, Frequency on Demand, Silicon Storage Technology, and Symmcom are registered trademarks of Microchip Technology Inc. in other countries.

GestIC is a registered trademark of Microchip Technology Germany II GmbH & Co. KG, a subsidiary of Microchip Technology Inc., in other countries.

All other trademarks mentioned herein are property of their respective companies.

© 2021, Microchip Technology Incorporated, All Rights Reserved.

ISBN: 978-1-5224-8061-7

For information regarding Microchip's Quality Management Systems, please visit [www.microchip.com/quality](http://www.microchip.com/quality).



# MICROCHIP

## Worldwide Sales and Service

### AMERICAS

**Corporate Office**  
2355 West Chandler Blvd.  
Chandler, AZ 85224-6199  
Tel: 480-792-7200  
Fax: 480-792-7277  
Technical Support:  
<http://www.microchip.com/support>  
Web Address:  
[www.microchip.com](http://www.microchip.com)

#### Atlanta

Duluth, GA  
Tel: 678-957-9614  
Fax: 678-957-1455

#### Austin, TX

Tel: 512-257-3370

#### Boston

Westborough, MA  
Tel: 774-760-0087  
Fax: 774-760-0088

#### Chicago

Itasca, IL  
Tel: 630-285-0071  
Fax: 630-285-0075

#### Dallas

Addison, TX  
Tel: 972-818-7423  
Fax: 972-818-2924

#### Detroit

Novi, MI  
Tel: 248-848-4000

#### Houston, TX

Tel: 281-894-5983

#### Indianapolis

Noblesville, IN  
Tel: 317-773-8323  
Fax: 317-773-5453  
Tel: 317-536-2380

#### Los Angeles

Mission Viejo, CA  
Tel: 949-462-9523  
Fax: 949-462-9608  
Tel: 951-273-7800

#### Raleigh, NC

Tel: 919-844-7510

#### New York, NY

Tel: 631-435-6000

#### San Jose, CA

Tel: 408-735-9110  
Tel: 408-436-4270

#### Canada - Toronto

Tel: 905-695-1980  
Fax: 905-695-2078

### ASIA/PACIFIC

**Australia - Sydney**  
Tel: 61-2-9868-6733

**China - Beijing**  
Tel: 86-10-8569-7000

**China - Chengdu**  
Tel: 86-28-8665-5511

**China - Chongqing**  
Tel: 86-23-8980-9588

**China - Dongguan**  
Tel: 86-769-8702-9880

**China - Guangzhou**  
Tel: 86-20-8755-8029

**China - Hangzhou**  
Tel: 86-571-8792-8115

**China - Hong Kong SAR**  
Tel: 852-2943-5100

**China - Nanjing**  
Tel: 86-25-8473-2460

**China - Qingdao**  
Tel: 86-532-8502-7355

**China - Shanghai**  
Tel: 86-21-3326-8000

**China - Shenyang**  
Tel: 86-24-2334-2829

**China - Shenzhen**  
Tel: 86-755-8864-2200

**China - Suzhou**  
Tel: 86-186-6233-1526

**China - Wuhan**  
Tel: 86-27-5980-5300

**China - Xian**  
Tel: 86-29-8833-7252

**China - Xiamen**  
Tel: 86-592-2388138

**China - Zhuhai**  
Tel: 86-756-3210040

### ASIA/PACIFIC

**India - Bangalore**  
Tel: 91-80-3090-4444

**India - New Delhi**  
Tel: 91-11-4160-8631

**India - Pune**  
Tel: 91-20-4121-0141

**Japan - Osaka**  
Tel: 81-6-6152-7160

**Japan - Tokyo**  
Tel: 81-3-6880-3770

**Korea - Daegu**  
Tel: 82-53-744-4301

**Korea - Seoul**  
Tel: 82-2-554-7200

**Malaysia - Kuala Lumpur**  
Tel: 60-3-7651-7906

**Malaysia - Penang**  
Tel: 60-4-227-8870

**Philippines - Manila**  
Tel: 63-2-634-9065

**Singapore**  
Tel: 65-6334-8870

**Taiwan - Hsin Chu**  
Tel: 886-3-577-8366

**Taiwan - Kaohsiung**  
Tel: 886-7-213-7830

**Taiwan - Taipei**  
Tel: 886-2-2508-8600

**Thailand - Bangkok**  
Tel: 66-2-694-1351

**Vietnam - Ho Chi Minh**  
Tel: 84-28-5448-2100

### EUROPE

**Austria - Wels**  
Tel: 43-7242-2244-39  
Fax: 43-7242-2244-393

**Denmark - Copenhagen**  
Tel: 45-4485-5910  
Fax: 45-4485-2829

**Finland - Espoo**  
Tel: 358-9-4520-820

**France - Paris**  
Tel: 33-1-69-53-63-20  
Fax: 33-1-69-30-90-79

**Germany - Garching**  
Tel: 49-8931-9700

**Germany - Haan**  
Tel: 49-2129-3766400

**Germany - Heilbronn**  
Tel: 49-7131-72400

**Germany - Karlsruhe**  
Tel: 49-721-625370

**Germany - Munich**  
Tel: 49-89-627-144-0  
Fax: 49-89-627-144-44

**Germany - Rosenheim**  
Tel: 49-8031-354-560

**Israel - Ra'anana**  
Tel: 972-9-744-7705

**Italy - Milan**  
Tel: 39-0331-742611  
Fax: 39-0331-466781

**Italy - Padova**  
Tel: 39-049-7625286

**Netherlands - Drunen**  
Tel: 31-416-690399  
Fax: 31-416-690340

**Norway - Trondheim**  
Tel: 47-7288-4388

**Poland - Warsaw**  
Tel: 48-22-3325737

**Romania - Bucharest**  
Tel: 40-21-407-87-50

**Spain - Madrid**  
Tel: 34-91-708-08-90  
Fax: 34-91-708-08-91

**Sweden - Gothenberg**  
Tel: 46-31-704-60-40

**Sweden - Stockholm**  
Tel: 46-8-5090-4654

**UK - Wokingham**  
Tel: 44-118-921-5800  
Fax: 44-118-921-5820

SYST-28PQGR961 - Data Sheet - BM62 / BM64 Datasheet Document Revision

Affected Catalog Part Numbers(CPN)

BM62SPKA1MC2-0001AA  
BM62SPKS1MC2-0001AA  
BM62SPKS1MC2-000CFG  
BM62SPKS1MC2-R002AA  
BM64SPKA1MC1-0001AA  
BM64SPKA1MC2-0001AA  
BM64SPKS1MC1-0001AA  
BM64SPKS1MC1-0003AA  
BM64SPKS1MC1-00M2AA  
BM64SPKS1MC1-H0M1AA  
BM64SPKS1MC1-M0M1AA  
BM64SPKS1MC1-Y001AA  
BM64SPKS1MC2-0001AA  
BM64SPKS1MC2-0002AA  
BM64SPKS1MC2-0003AA  
BM64SPKS1MC2-00M3AA  
BM64SPKS1MC2-A0M1AA  
BM64SPKS1MC2-H0M1AA  
BM64SPKS1MC2-T001BA  
BM64SPKS1MC2-Y001AA  
BM64SPKS1MC2-Y003AA  
BM64SPKS1MC2-Y004AA  
BM64SPKS1MC2-Y005AA  
BM64SPKS1MC2-Y007AA  
BM64SPKS1MC2-Y008AA  
BM64SPKS1MC2-Y0M2AA  
BM64SPKS1MC2-Y0M3AA