



Product Change Notification / LIAL-21DKJL279

Date:

27-Jan-2021

Product Category:

8-bit Microcontrollers, Analog to Digital Converters, Battery Management and Fuel Gauges - Battery Chargers, Digital Potentiometers, Digital to Analog Converters, Instrumentation Amplifier, Memory, Power Management - PWM Controllers, Temperature Sensors

PCN Type:

Manufacturing Change

Notification Subject:

CCB 4439.001 and 4439.002 Final Notice: Qualification of MMT as an additional assembly site for selected products available 8L DFN (3x3x0.9mm) and (2x3x0.9mm) packages.

Affected CPNs:

[LIAL-21DKJL279_Affected_CPN_01272021.pdf](#)

[LIAL-21DKJL279_Affected_CPN_01272021.csv](#)

Notification Text:

PCN Status:Final notification.

PCN Type: Manufacturing Change

Microchip Parts Affected:Please open one of the icons found in the Affected CPNs section above.

NOTE: For your convenience Microchip includes identical files in two formats (.pdf and .xls).

Description of Change: Qualification of MMT as an additional assembly site for selected products available 8L DFN (3x3x0.9mm and 2x3x0.9mm) packages.

Pre Change:

Assembled at NSEB using gold (Au) bond wire or palladium coated copper with gold flash (CuPdAu) bond wire, 8600 die attach material, EFTEC-64T lead frame or C194 lead frame material, Ag DAP surface prep or Bare Cu DAP surface prep and without lead lock lead frame

Post Change:

Assembled at NSEB using gold (Au) bond wire or palladium coated copper with gold flash (CuPdAu) bond wire, 8600 die attach material, EFTEC-64T lead frame or C194 lead frame material, Ag DAP surface prep or Bare Cu DAP surface prep and without lead lock lead frame

or Assembled at MMT using palladium coated copper with gold flash (CuPdAu) bond wire, 3280 die attach material, C194 lead frame material, Bare Cu DAP surface prep and with lead lock lead frame.

Pre and Post Change Summary:

	Pre Change		Post Change		
Assembly Site	UTAC Thai Limited (UTL-1) LTD. NSEB		UTAC Thai Limited (UTL-1) LTD. NSEB		Microchip Technology Thailand (Branch)/MMT
Wire material	Au	CuPdAu	Au	CuPdAu	CuPdAu
Die attach material	8600		8600		3280
Molding compound material	G700LTD		G700LTD		G700LTD
Lead frame material	EFTEC-64T	C194	EFTEC-64T	C194	C194
Lead Frame DAP Surface Prep	Ag	Bare Cu	Ag	Bare Cu	Bare Cu
Lead frame lead-lock	No		No		Yes
	See Pre and Post Change attachment for lead frame comparison.				

Impacts to Data Sheet: None

Change Impact:None

Reason for Change:To improve on-time delivery performance by qualifying MMT as an additional assembly site.

Change Implementation Status:In Progress

Estimated First Ship Date February 10, 2021 (date code: 2108)

NOTE: Please be advised that after the estimated first ship date customers may receive pre and post change parts.

Time Table Summary:

	January 2021					February 2021			
Workweek	01	02	03	04	05	06	07	08	09

Qual Report Availability					X				
Final PCN Issue Date					X				
Estimated Implementation Date								X	

Method to Identify Change: Traceability code.

Qualification Report Please open the attachments included with this PCN labeled as PCN_#_Qual_Report.

Revision History: January 27, 2021: Issued final notification. Attached the Qualification Report. Provided estimated first ship date to be on February 10, 2021.

The change described in this PCN does not alter Microchip’s current regulatory compliance regarding the material content of the applicable products.

Attachments:

[PCN_LIAL-21DKJL279_Qual_Report.pdf](#)
[PCN_LIAL-21DKJL279_Pre and Post Change Summary.pdf](#)

Please contact your local [Microchip sales office](#) with questions or concerns regarding this notification.

Terms and Conditions:

If you wish to receive Microchip PCNs via email please register for our PCN email service at our [PCN home page](#) select register then fill in the required fields. You will find instructions about registering for Microchips PCN email service in the [PCN FAQ](#) section.

If you wish to change your PCN profile, including opt out, please go to the [PCN home page](#) select login and sign into your myMicrochip account. Select a profile option from the left navigation bar and make the applicable selections.

**CCB 4439.001 and 4439.002
Pre and Post Change Summary
Lead Frame Comparison
PCN#: LIAL-21DKJL279**



A Leading Provider of Smart, Connected and Secure Embedded Control Solutions



SMART | CONNECTED | SECURE

Lead frame comparison

8L DFN (3x3x0.9mm)

Pre change

NSEB

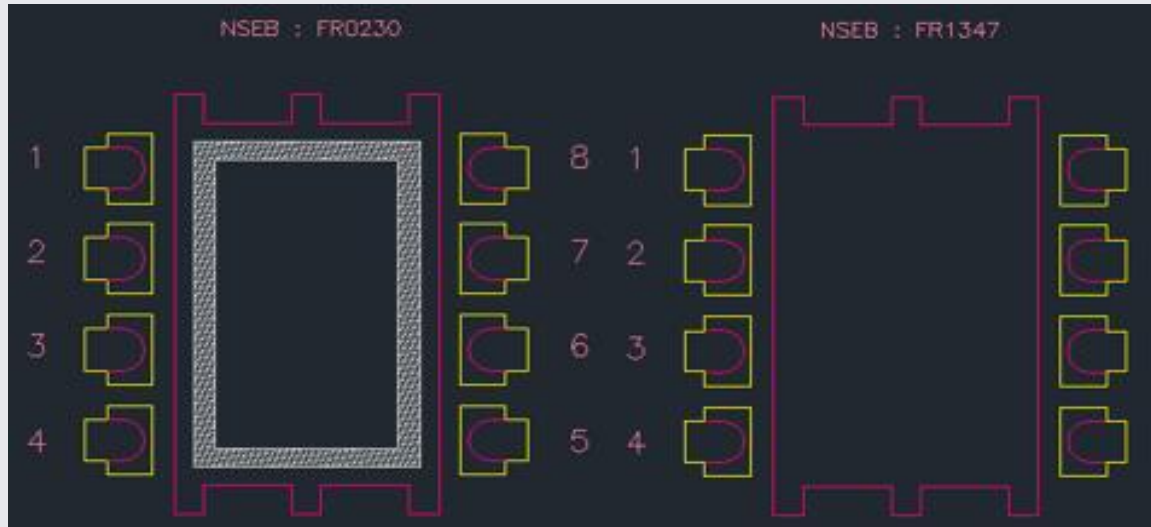

Lead frame lead-lock

No

Post Change

MMT

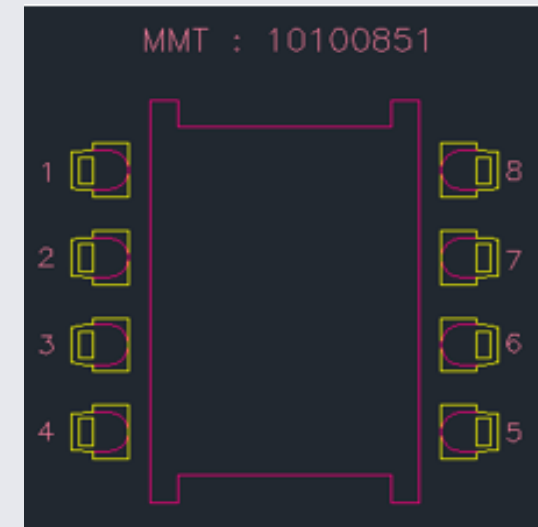

Lead frame lead-lock

Yes

Lead frame comparison

8L DFN (2x3x0.9mm)

Pre change

NSEB

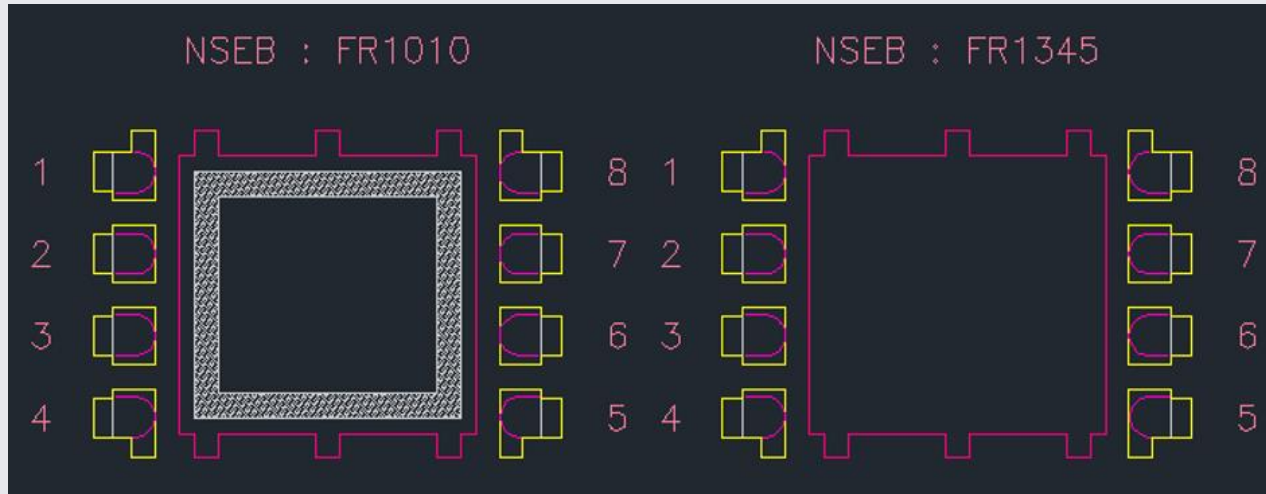

Lead frame lead-lock

No

Post Change

MMT

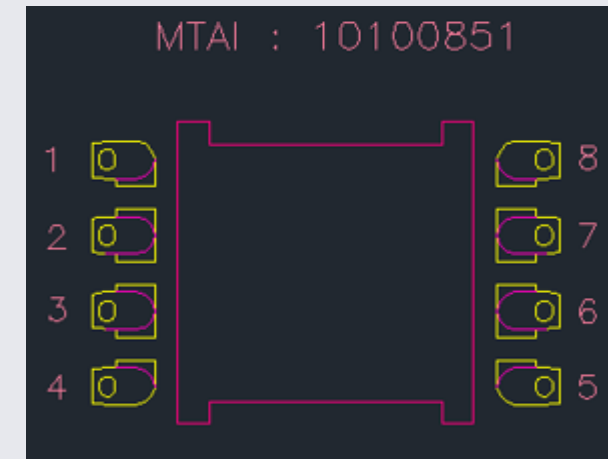

Lead frame lead-lock

Yes



MICROCHIP

QUALIFICATION REPORT SUMMARY
RELIABILITY LABORATORY

PCN: LIAL-21DKJL279

Date
January 07, 2021

Qualification of palladium coated copper with gold flash (CuPdAu) bond wire for selected products available in 8L DFN (4x4x0.9mm) package at MMT assembly site. The selected products available 8L DFN (3x3x0.9mm and 2x3x0.9mm) packages will qualify by similarity (QBS).

PACKAGE QUALIFICATION REPORT

Purpose Qualification of palladium coated copper with gold flash (CuPdAu) bond wire for selected products available in 8L DFN (4x4x0.9mm) package at MMT assembly site. The selected products available in 8L DFN (3x3x0.9mm and 2x3x0.9mm) packages will qualify by similarity (QBS).

CN ES349645
QUAL ID R2000836 Rev. A
MP CODE DE0244M8XAXF
Part No. PIC12F683-E/MD
Bonding No. BDM-002739 Rev. A
CCB No. 4439, 4439.001 and 4439.002

Package

Type 8L DFN
Package size 4x4x0.9 mm

Lead Frame

Paddle size 114 x 146 mils
Material A194
Surface Ag selective plated on paddle
Process Etched
Lead Lock Yes
Part Number 10100845

Material

Epoxy 3280
Wire CuPdAu
Mold Compound G700LTD
Plating Composition Matte Sn

PACKAGE QUALIFICATION REPORT

Manufacturing Information

Assembly Lot No.	Wafer Lot No.	Date Code
MMT-213001957.000	TMPE219226894.210	2043G35
MMT-218001958.000	TMPE219226894.210	2043G36
MMT-213001569.000	TMPE219226894.210	2043CYA

Result

Pass Fail _____

8L DFN (4x4x0.9 mm) assembled by MMT pass reliability test per QCI-39000.
This package was qualified the Moisture/Reflow Sensitivity Classification Level 1 at 260°C reflow temperature per IPC/JEDEC J-STD-020E standard.

PACKAGE QUALIFICATION REPORT

Test Number (Reference)	Test Condition	Standard/ Method	Qty. (Acc.)	Def/SS	Result	Remarks
<u>Precondition</u> <u>Prior Perform</u> <u>Reliability Tests</u> (At MSL Level 1)	Electrical Test: +25°C and 125°C System: J750	JESD22- A113	693(0)	693		Good Devices
	Bake 150°C, 24 hrs System: CHINEE	JIP/ IPC/JEDEC J-STD-020E		693		
	85°C/85%RH Moisture Soak 168 hrs. System: TABAI ESPEC Model PR-3SPH			693		
	3x Convection-Reflow 265°C max System: Vitronics Soltec MR1243			693		
	Electrical Test: +25°C and 125°C System: J750				0/693	Pass

PACKAGE QUALIFICATION REPORT

Test Number (Reference)	Test Condition	Standard/ Method	Qty. (Acc.)	Def/SS.	Result	Remarks
Temp Cycle	Stress Condition: -65°C to +150°C, 500 Cycles System: TABAI ESPEC TSA-70H Electrical Test: +125°C System: J750	JESD22-A104		231		Parts had been pre-conditioned at 260°C 77 units / lot
	Stress Condition: -65°C to +150°C, 1000 Cycles System: TABAI ESPEC TSA-70H Electrical Test: +125°C System: J750		231(0)	0/231	Pass	
	Bond Strength: Wire Pull (> 2.5 grams) Bond Shear (>15.00 grams)		15 (0)	0/15	Pass	
			15 (0)	0/15	Pass	
UNBIASED-HAST	Stress Condition: +130°C/85%RH, 96 hrs. System: HAST 6000X Electrical Test: +25°C System: J750	JESD22-A118		231		Parts had been pre-conditioned at 260°C 77 units / lot
	Stress Condition: +130°C/85%RH, 192 hrs. System: HAST 6000X Electrical Test: +25°C System: J750		231(0)	0/231	Pass	
			231(0)	0/231	Pass	
HAST	Stress Condition: +130°C/85%RH, 96 hrs. Bias Volt: 5.0 Volts System: HAST 6000X Electrical Test: +25°C and 125°C System: J750	JESD22-A110		231		Parts had been pre-conditioned at 260°C 77 units / lot
	Stress Condition: +130°C/85%RH, 192 hrs. Bias Volt: 5.0 Volts System: HAST 6000X Electrical Test: +25°C and 125°C System: J750		231(0)	0/231	Pass	
			231(0)	0/231	Pass	

PACKAGE QUALIFICATION REPORT

Test Number (Reference)	Test Condition	Standard/ Method	Qty. (Acc.)	Def/SS.	Result	Remarks
High Temperature Storage Life	Stress Condition: Bake 175°C, 504 hrs System: SHEL LAB	JESD22- A103		45		45 units
	Electrical Test: +25°C and 125°C System: J750		45(0)	0/45	Pass	
Wire sweep	Wire sweep Inspection 15 Wires / lot	-	45(0) Wires	0/45	Pass	
Bond Strength Data Assembly	Wire Pull (> 2.5 grams)	Mil. Std. 883-2011	30 (0) Wires	0/30	Pass	
	Bond Shear (>15.00 grams)	CDF-AEC- Q100-001	30 (0) bonds	0/30	Pass	

Affected Catalog Part Numbers(CPN)

PIC10F204-I/MC
PIC10F204T-I/MC
PIC10F206-E/MC
PIC10F206-I/MC
PIC10F206T-I/MC
PIC12F508-E/MC
PIC12F508-I/MC
PIC12F508T-I/MC
PIC12F509-E/MC
PIC12F509-I/MC
PIC12F509T-I/MC
25LC010AT-I/MC
25AA010AT-I/MC
25LC010AT-E/MC
25LC020AT-I/MC
25AA020AT-I/MC
25LC020AT-E/MC
25LC040AT-I/MC
25AA040AT-I/MC
25LC040AT-E/MC
MCP73831-2ACI/MC
MCP73831-2ATI/MC
MCP73831-2DCI/MC
MCP73831-3ACI/MC
MCP73831-4ADI/MC
MCP73831-5ACI/MC
MCP73831T-2ACI/MC
MCP73831T-2ATI/MC
MCP73831T-2DCI/MC
MCP73831T-3ACI/MC
MCP73831T-4ADI/MC
MCP73831T-5ACI/MC
MCP73832-2ACI/MC
MCP73832-2ATI/MC
MCP73832-2DCI/MC
MCP73832-3ACI/MC
MCP73832-4ADI/MC
MCP73832-5ACI/MC
MCP73832T-2ACI/MC
MCP73832T-2ATI/MC
MCP73832T-2DCI/MC
MCP73832T-3ACI/MC

MCP73832T-4ADI/MC
MCP73832T-5ACI/MC
MCP9805-BE/MC
MCP9805T-BE/MC
PIC10F220-E/MC
PIC10F220-I/MC
PIC10F220T-I/MC
PIC10F220T-E/MC
PIC10F222-I/MC
PIC10F222T-I/MC
MCP98242-BE/MC
MCP98242-BE/MCBA2
MCP4132-104E/MF
MCP4132-503E/MF
MCP4142-502E/MF
MCP4142-103E/MF
MCP4142-104E/MF
MCP4142-503E/MF
MCP4152-502E/MF
MCP4152-103E/MF
MCP4152-104E/MF
MCP4152-503E/MF
MCP4162-502E/MF
MCP4162-103E/MF
MCP4162-104E/MF
MCP4162-503E/MF
MCP4131T-502E/MF
MCP4131T-103E/MF
MCP4131T-104E/MF
MCP4131T-503E/MF
MCP4141T-502E/MF
MCP4141T-103E/MF
MCP4141T-104E/MF
MCP4141T-503E/MF
MCP4151T-502E/MF
MCP4151T-103E/MF
MCP4151T-104E/MF
MCP4151T-503E/MF
MCP4161T-502E/MF
MCP4161T-103E/MF
MCP4161T-104E/MF
MCP4161T-503E/MF
MCP4132T-502E/MF
MCP4132T-103E/MF
MCP4132T-104E/MF
MCP4132T-503E/MF
MCP4142T-502E/MF

MCP4142T-103E/MF
MCP4142T-104E/MF
MCP4142T-503E/MF
MCP4152T-502E/MF
MCP98242-CE/MC
MCP98242T-BE/MC
MCP98242T-BE/MCBA2
MCP98242T-BE/MCBA3
MCP98242T-BE/MCBAA
MCP98242T-BE/MCBAB
MCP98242T-BE/MCBAC
MCP98242T-CE/MC
PIC12F615-E/MF
PIC12F615-I/MF
PIC12F615T-I/MF
PIC12F615T-E/MF
PIC12HV615-E/MF
PIC12HV615-I/MF
PIC12HV615T-I/MF026
PIC12HV615T-I/MF027
PIC12HV615T-I/MF028
PIC12HV615T-I/MF030
PIC12HV615T-I/MF
PIC12F609-E/MF
PIC12F609-I/MF
PIC12HV609-E/MF
MCP9804-E/MC
MCP9804-E/MCBBB
MCP9804T-E/MC
MCP9804T-E/MCBBB
MCP9808T-E/MC
MCP3422A0-E/MC
MCP3426A0-E/MC
MCP3422A0T-E/MC
MCP3426A0T-E/MC
MCP3422A1-E/MC
MCP3426A1-E/MC
MCP3422A1T-E/MC
MCP3426A1T-E/MC
MCP3422A2-E/MC
MCP3426A2-E/MC
MCP3422A2T-E/MC
MCP3426A2T-E/MC
MCP3422A3-E/MC
MCP3426A3-E/MC
MCP3422A3T-E/MC
MCP3426A3T-E/MC

MCP3422A4-E/MC
MCP3426A4-E/MC
MCP3422A4T-E/MC
MCP3426A4T-E/MC
MCP3422A5-E/MC
93LC86CT-I/MC
93AA86CT-I/MC
MCP3426A7-E/MC
MCP3422A7T-E/MC
MCP3426A7T-E/MC
24LC64T-I/MC
24AA64T-I/MC
24LC08BT-I/MC
24AA08T-I/MC
24LC16B-E/MC
24LC16B-I/MC
24AA16-I/MC
24LC16BT-I/MC
24AA16T-I/MC
24LC16BT-E/MC
24LC01BT-I/MC
24AA01T-I/MC
24LC01BT-E/MC
24LC02BT-I/MC
24AA02T-I/MC
24LC04BT-I/MC
24AA04T-E/MC
24LC32AT-I/MC
24AA32AT-I/MC
24AA32AT-I/MCB27
24LC32AT-E/MC
93LC46AT-I/MC
93AA46AT-I/MC
93LC46BT-I/MC
93AA46BT-I/MC
93C46BT-I/MC
93C46AT-I/MC
93LC46CT-I/MC
93AA46CT-I/MC
93LC56CT-I/MC
93AA56CT-I/MC
93LC56AT-I/MC
93AA56AT-I/MC
93LC56BT-I/MC
93AA56BT-I/MC
93LC56CT-E/MC
93LC66CT-I/MC

93AA66CT-I/MC
93LC66AT-I/MC
93AA66AT-I/MC
93LC66BT-I/MC
93AA66BT-I/MC
93C46CT-I/MC
93C56CT-I/MC
93C56AT-I/MC
93C56BT-I/MC
93C66CT-I/MC
93C66AT-I/MC
93C66BT-I/MC
93LC76CT-I/MC
93AA76CT-I/MC
93C76CT-I/MC
93C86CT-I/MC
MCP4021T-202E/MC
MCP4021T-502E/MC
MCP4021T-103E/MC
MCP4021T-503E/MC
MCP4011T-202E/MC
MCP4011T-502E/MC
MCP4011T-103E/MC
MCP4011T-503E/MC
MCP4131-502E/MF
MCP4131-103E/MF
MCP4131-104E/MF
MCP4131-503E/MF
MCP4141-502E/MF
MCP4141-103E/MF
MCP4141-104E/MF
MCP4141-503E/MF
MCP4151-502E/MF
MCP4151-103E/MF
MCP4151-104E/MF
MCP4151-503E/MF
MCP4161-502E/MF
MCP4161-103E/MF
MCP4161-104E/MF
MCP4161-503E/MF
MCP4132-502E/MF
MCP4132-103E/MF
PIC12HV752-I/MF
MCP1632-AAE/MC
MCP1632-BAE/MC
MCP1632T-AAE/MC
MCP1632T-BAE/MC

MCP6N16-001E/MF
MCP6N16T-001E/MF
MCP6N16-010E/MF
MCP6N16T-010E/MF
MCP6N16-100E/MF
MCP6N16T-100E/MF
24LC08B-E/MC
24LC08B-I/MC
24AA08-I/MC
24LC08BT-E/MC
24LC32AT-I/MCA28
24FC64-I/MC
24FC64T-I/MC
24LC64T-E/MC
24LC04B-E/MC
24LC04B-I/MC
24AA04-I/MC
24AA04T-I/MC
24LC04BT-E/MC
MCP98243-BE/MC
MCP98243T-BE/MC
MCP98243T-BE/MCAA
MCP98243T-BE/MCAB
MCP9843-BE/MC
MCP9843T-BE/MC
MCP4801-E/MC
MCP4811-E/MC
MCP4821-E/MC
MCP4901-E/MC
MCP4911-E/MC
MCP4921-E/MC
MCP4801T-E/MC
MCP4811T-E/MC
MCP4821T-E/MC
MCP4901T-E/MC
MCP4911T-E/MC
MCP4921T-E/MC
PIC12F752-E/MF
PIC12F752-I/MF
PIC12F752T-I/MF
PIC12HV752-E/MF
MCP4152T-103E/MF
MCP4152T-104E/MF
MCP4152T-503E/MF
MCP4162T-502E/MF
MCP4162T-103E/MF
MCP4162T-104E/MF

MCP4162T-503E/MF
MCP4542-103PE/MF
MCP4562-103PE/MF
MCP4542T-103PE/MF
MCP4562T-103PE/MF
MCP4531T-502E/MF
MCP4531T-103E/MF
MCP4531T-104E/MF
MCP4531T-503E/MF
MCP4532T-502E/MF
MCP4532T-103E/MF
MCP4532T-104E/MF
MCP4532T-503E/MF
MCP4541T-502E/MF
MCP4541T-103E/MF
MCP4541T-104E/MF
MCP4541T-503E/MF
MCP4542T-502E/MF
MCP4542T-103E/MF
MCP4542T-104E/MF
MCP4542T-503E/MF
MCP4551T-502E/MF
MCP4551T-103E/MF
MCP4551T-104E/MF
MCP4551T-503E/MF
MCP4552T-502E/MF
MCP4552T-103E/MF
MCP4552T-104E/MF
MCP4552T-503E/MF
MCP4561T-502E/MF
MCP4561T-103E/MF
MCP4561T-104E/MF
MCP4561T-503E/MF
MCP4562T-502E/MF
MCP4562T-103E/MF
MCP4562T-104E/MF
MCP4562T-503E/MF
MCP4561T-503E/MFOPP
MCP4562T-104QE/MF
MCP4562T-503QE/MF
PIC12F510-E/MC
PIC12F510-I/MC
PIC12F510T-I/MC
PIC12F510T-E/MC
PIC12F519-E/MC
PIC12F519-I/MC
PIC12F519T-I/MC034

MCP3426A5-E/MC
MCP3422A5T-E/MC
MCP3426A5T-E/MC
MCP3422A6-E/MC
MCP3426A6-E/MC
MCP3422A6T-E/MC
MCP3426A6T-E/MC
MCP3422A7-E/MC
PIC12F519T-I/MC
PIC12F519T-E/MC046
PIC12F617-E/MF
PIC12F617-I/MF
PIC12F617T-I/MF
PIC12F617T-E/MF049
PIC12F617T-E/MF061
PIC12F617T-E/MF064
PIC10F200-E/MC
PIC10F200-I/MC
PIC10F200T-I/MC
PIC10F202-E/MC
PIC10F202-I/MC
PIC10F202T-I/MC

ably site for selected products available 8L DFN (3x3x0.9mm) and (2x3x0.9mm) packages.