

Not Recommended for New Design : PAN1761 Series Bluetooth Low Energy RF Modules

NRFND.PG 15.2.18.2020

2.18.2020

About This Notice:	The PAN1761 Series Wireless Connectivity RF Modules and Evaluation Kits are now Not Recommended for New Design by Panasonic due to the discontinuation of internal components .
Features:	Bluetooth Low energy 4.1 and NFC capable combo .
Effective Date :	Immediate
Affected Parts and/or Replacements :	See Attached .
Datasheet(s):	See Attached .
Notes:	

PAN1761

Bluetooth Low Energy & NFC Combo Module

Product Specification

Rev. 1.2

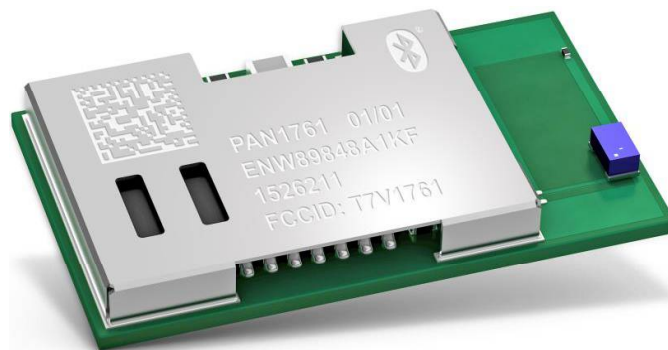

Overview

The PAN1761 is a short-range BLE and NFC single mode module used for the implementation of Bluetooth functionality into various electronic devices.

Features

- Small 15.6 mm x 8.7 mm x 1.9 mm SMD module
- Same form factor and pinout as PAN1026, PAN1760, and PAN1760A
- Bluetooth Low Energy (BLE) 4.1 compliant
- 512 kbit EEPROM memory
- Host mode
- Standard SIG BLE profiles as well as SPPoverBLE profiles available in the SDK
- UART, I2C & SPI interface, PWM output (3x), ADC (3x), 10 programmable I/O

NFC

- Almost zero power consumption in standby mode by using NFC wake up
- Dedicated Bluetooth partner selection by simple device approximation
- Support for true out-of-band Bluetooth pairing

Characteristics

- Receiver sensitivity -91 dBm typ.
- Output power 0 dBm maximum setting
- Power supply 1.8 V to 3.6 V single operation voltage
- Transmit power consumption @0dBm 5.8 mA
- Low Power 5 μ A Sleep mode
- NFC Forum Type 3 compliant NFC tag (external antenna)
- Operating temperature range -30 °C to +85 °C

Bluetooth

- GAP central and peripheral support for LE
- GATT, SMP, and SDB support for LE
- Support for Over-the-Air update
- Support for Scatternet/Mesh network
- Frequent changing of device address (improved privacy, reduced tracking ability)
- Larger packet sizes (more efficient application and network layer security)

Block Diagram

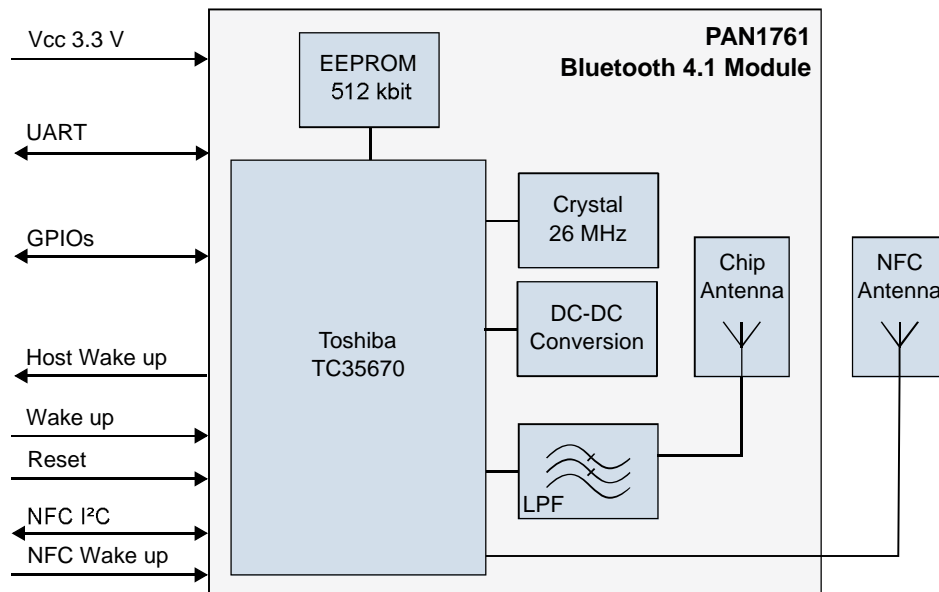

By purchase of any of the products described in this document the customer accepts the document's validity and declares their agreement and understanding of its contents and recommendations. Panasonic reserves the right to make changes as required at any time without notification. Please consult the most recently issued Product Specification before initiating or completing a design.

© Panasonic Industrial Devices Europe GmbH 2017.

This specification sheet is copyrighted. Reproduction of this document is permissible only if reproduction is without alteration and is accompanied by all associated warranties, conditions, limitations, and notices. Do not disclose it to a third party.

All rights reserved.

This Product Specification does not lodge the claim to be complete and free of mistakes.

Engineering Samples (ES)

If Engineering Samples are delivered to the customer, these samples have the status "Engineering Samples". This means that the design of this product is not yet concluded. Engineering Samples may be partially or fully functional, and they may differ from the published Product Specification.

Engineering Samples are not qualified and they are not to be used for reliability testing or series production.

Disclaimer

The customer acknowledges that samples may deviate from the Product Specification and may bear defects due to their status of development and the lack of qualification mentioned above.

Panasonic rejects any liability or product warranty for Engineering Samples. In particular, Panasonic disclaims liability for damages caused by:

- The use of the Engineering Sample other than for evaluation purposes, particularly the installation or integration in another product to be sold by the customer,
- Deviation or lapse in function of the Engineering Sample,
- Improper use of the Engineering Sample.

Panasonic Industrial Devices Europe GmbH disclaims any liability for consequential and incidental damages. In case of any queries regarding the Engineering Samples, please contact your local sales partner or the related product manager.

Table of Contents

1	About This Document	5
1.1	Purpose and Audience	5
1.2	Revision History.....	5
1.3	Use of Symbols	5
1.4	Related Documents	5
2	Overview	6
2.1	Block Diagram	7
2.2	Bluetooth IC.....	7
2.3	Pin Configuration	8
3	Detailed Description	11
3.1	Dimensions.....	11
3.2	Footprint	12
3.3	Packaging.....	13
3.4	Case Marking	16
4	Specification	17
4.1	Default Test Conditions	17
4.2	Absolute Maximum Ratings.....	17
4.3	Recommended Operating Conditions.....	18
4.4	Power Up Sequence.....	18
4.5	Current Consumption.....	18
4.6	Bluetooth RF Performance	19
4.7	Antenna Radiation Pattern.....	21
4.8	Reliability Tests	22
4.9	Recommended Soldering Profile	23
5	Cautions	24
5.1	Design Notes	24
5.2	Installation Notes	24
5.3	Usage Condition Notes.....	25
5.4	Storage Notes.....	25
5.5	Safety Cautions	25
5.6	Other Cautions	26
5.7	Life Support Policy.....	26
6	Regulatory and Certification Information	27
6.1	RoHS and REACH Declaration	27
6.2	Federal Communications Commission (FCC) for US	27
6.3	Industry Canada Certification	29
6.4	European Conformity According to RED (2014/53/EU)	32
7	Appendix	33
7.1	Ordering Information.....	33
7.2	Contact Details	34

1 About This Document



1.1 Purpose and Audience

This Product Specification provides details on the functional, operational, and electrical characteristics of the Panasonic PAN1761 module. It is intended for hardware design, application, and Original Equipment Manufacturers (OEM) engineers. The product is referred to as “the PAN1761” or “the module” within this document.

1.2 Revision History

Revision	Date	Modifications/Remarks
0.1	November 2015	1st preliminary version.
0.2	January 2016	PIN Table correction.
0.3	February 2016	Minor changes.
0.6	23.08.2016	Bluetooth 4.1
0.7	3.11.2016	Changes in power supply values and conditions during measurement of output power and sensitivity
1.0	January 2017	Final version
1.1	March 2017	Updated temperature range
1.2	July 2017	New document structure and layout

1.3 Use of Symbols

Symbol	Description
	<p>Note</p> <p>Indicates important information for the proper use of the product. Non-observance can lead to errors.</p>
	<p>Attention</p> <p>Indicates important notes that, if not observed, can put the product's functionality at risk.</p>
⇒ [chapter number] [chapter title]	<p>Cross reference</p> <p>Indicates cross references within the document.</p> <p>Example:</p> <p>Description of the symbols used in this document ⇒ 1.3 Use of Symbols.</p>

1.4 Related Documents

Please refer to the Panasonic website for related documents ⇒ [7.2.2 Product Information](#).

2 Overview

The PAN1761 is based on Toshiba's single chip TC35670 Bluetooth semiconductor device with embedded Toshiba Bluetooth 4.1 LE stack, GATT profile, and an NFC Forum Type 3 compliant NFC tag. Peak power consumption of only 5.8 mA in Tx mode allows advanced wireless functionalities in IoT, medical, and industrial applications without compromising battery life. Additionally, NFC allows products to wake up from zero standby power consumption to full Bluetooth operation. Highly secure Bluetooth connections are created using NFC to exchange link keys.

The PAN1761 can be operated in Host mode for very simple integration of Bluetooth connectivity into existing products. The PAN1761 and the PAN1026 share the same footprint. Only minor code changes are required when migrating from PAN1026. Previously developed software (Bluetooth Low Energy profiles and applications) can be easily migrated with a minimal effort.

FCC, IC, and CE approval are available.

Please refer to the Panasonic website for related documents [⇒ 7.2.2 Product Information](#).

Further information on the variants and versions [⇒ 7.1 Ordering Information](#).

2.1 Block Diagram

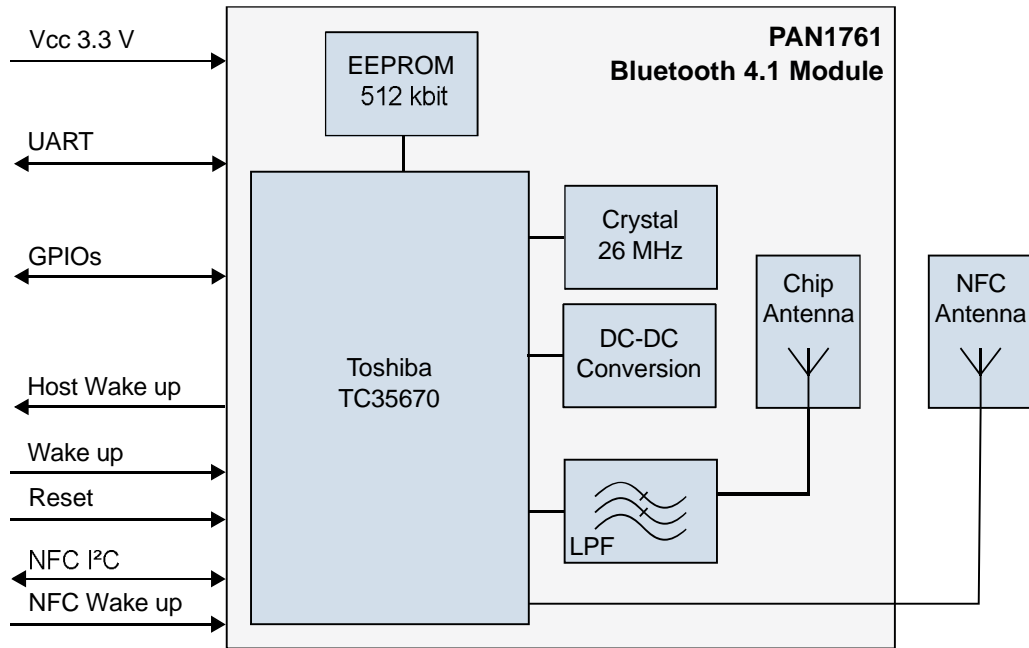

2.2 Bluetooth IC

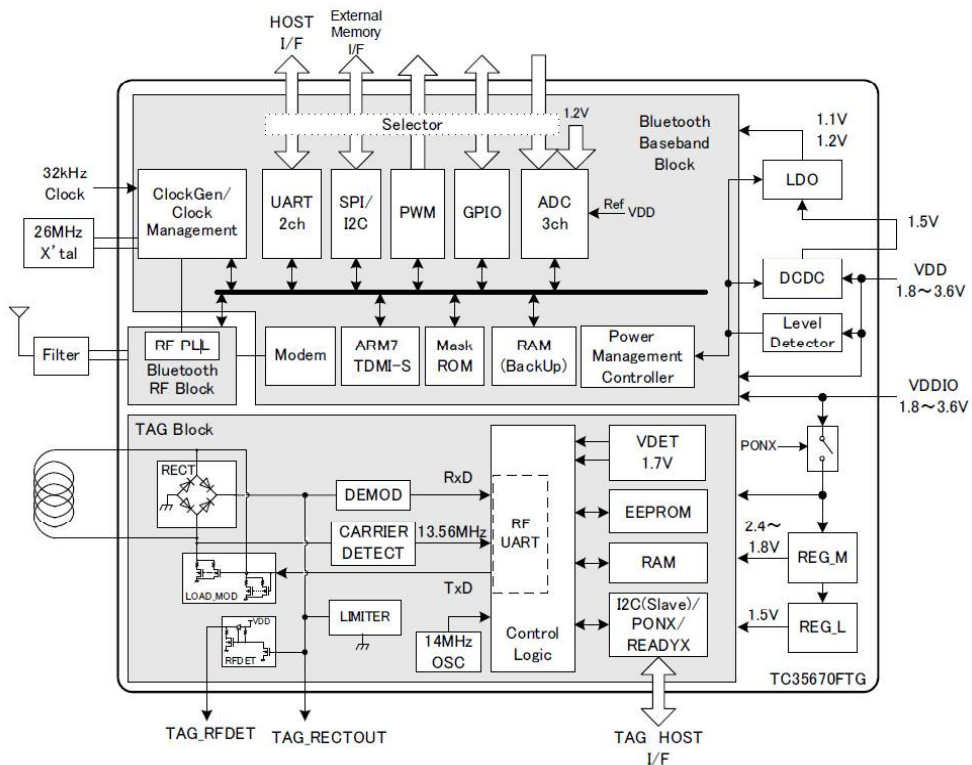

2.3 Pin Configuration

Pin Assignment

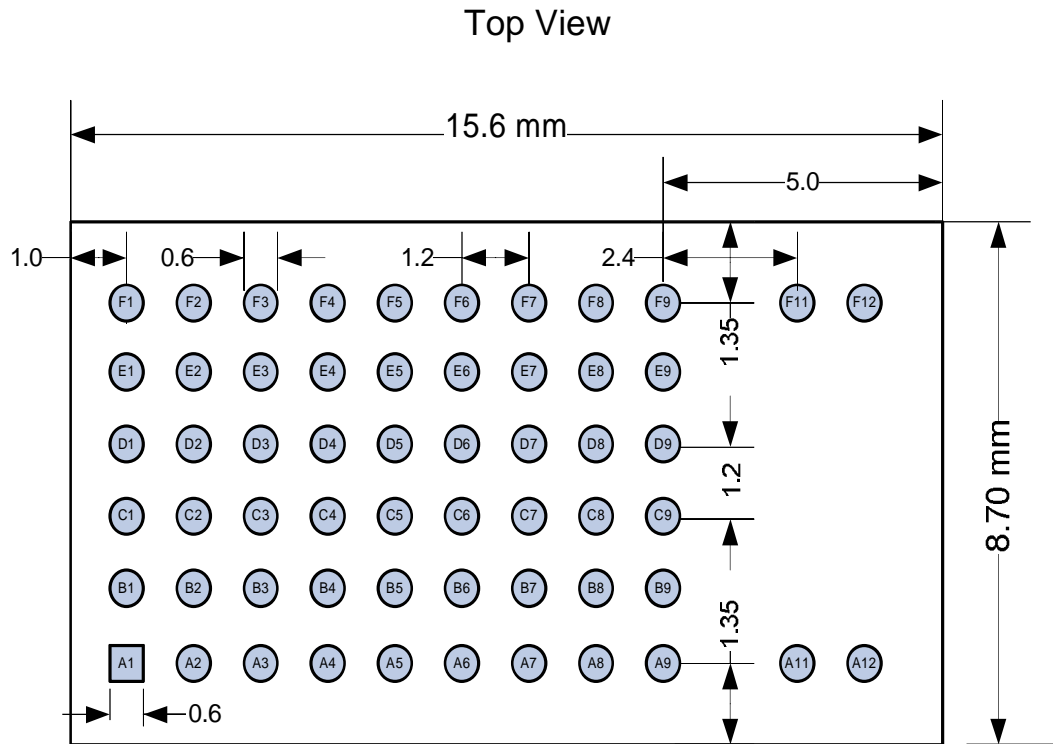

Pin Functions

No	Pin Name	GPIO No	Pin Type	Description
A1	GND		Ground pin	Connect to ground
A2	NC			Not connected
A3	Reset		Digital input	Reset, active-low
A4	VCC		Power	2 V – 3.6 V analog/digital power supply connection
A5	VCC		Power	2 V – 3.6 V analog/digital power supply connection
A6	VCC		Power	2 V – 3.6 V analog/digital power supply connection
A7	GND		Ground pin	Connect to ground
A8	NC			Not connected

No	Pin Name	GPIO No	Pin Type	Description
A9	GND			Connect to ground
A11	GND			Connect to ground
A12	GND			Connect to ground
B1	NC			Not connected
B2	TAG_L0		NFC_Antenna	
B3	TAG_SCL		NFC_I2C	
B4	NC			Not connected
B5	NC			Not connected
B6	NC			Not connected
B7	NC			Not connected
B8	NC			Not connected
B9	NC			Not connected
C1	NC			Not connected
C2	TAG_L1		NFC_Antenna	
C3	TAG_RFDET		Digital Out	
C4	NC			Not connected
C5	NC			Not connected
C6	TAG_READYX		Digital Out	
C7	TAG_SDA	PWM2	NFC_I2C	
C8	GND		Ground Pin	Connect to ground
C9	GND		Ground Pin	Connect to ground
D1	NC			Not connected
D2	NC			Not connected
D3	GPIO1	AIN0	Digital I/O	
D4	Wakeup	GPIO0	Digital I/O	
D5	NC			Not connected
D6	TAG_PONX		Digital In	
D7	GND		Ground Pin	Connect to ground
D8	GND		Ground Pin	Connect to ground
D9	NC			Not connected/placeholder for antenna

No	Pin Name	GPIO No	Pin Type	Description
E1	GPIO8	SDA	Digital I/O	Connected to internal EEPROM
E2	GPIO7	SCL	Digital I/O	Connected to internal EEPROM
E3	NC			Not connected
E4	NC			Not connected
E5	TAG_RECTOUT			
E6	UART_RXD	GPIO4	Digital In	
E7	GPIO2	PWM0/AIN1	Digital I/O	
E8	GND		Ground Pin	Connect to ground
E9	GND		Ground Pin	Connect to ground
F1	GND		Ground Pin	Connect to ground
F2	EEPROM_WP		Digital In	EEPROM write protect /active low
F3	NC			Not connected
F4	NC			Not connected
F5	GPIO6	UART_1-CTS/ UART2-RX	Digital In	Can be configured to UART2_RXD
F6	SLEEPXCLKIN		Clock	32.768 KHz sleep clock input
F7	UART_TXD	GPIO3	Digital Out	
F8	GPIO5	UART1_RT S/ UART2- TX	Digital I/O	Can be configured to UART2_TXD
F9	GND		Ground Pin	Connect to ground
F11	GND		Ground Pin	Connect to ground
F12	GND		Ground Pin	Connect to ground

3 Detailed Description

3.1 Dimensions



All dimensions are in millimeters.

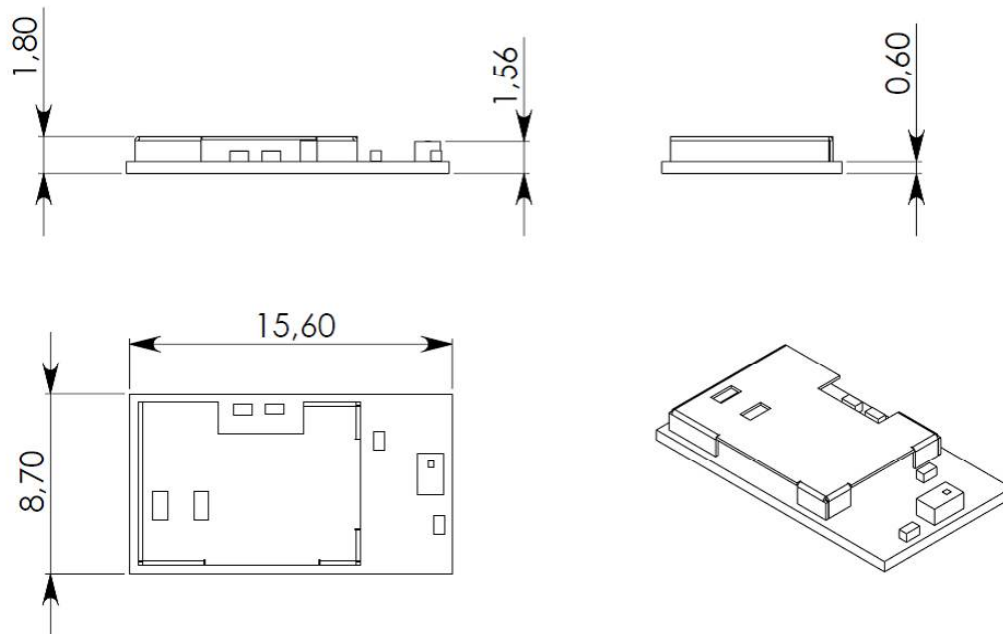

No.	Item	Dimension	Tolerance	Remark
1	Width	8.70	± 0.30	
2	Length	15.60	± 0.30	
3	Height	1.80	± 0.20	With case

3.2 Footprint



The outer dimensions have a tolerance of ± 0.3 mm.

Top View

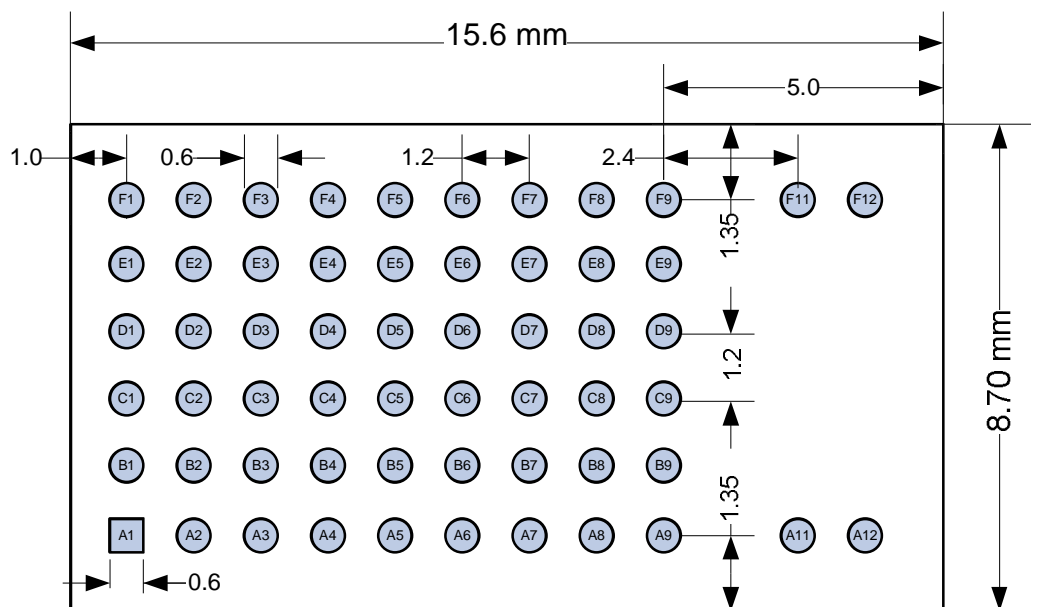

3.3 Packaging

The product is a mass production status product and will be delivered in the package described below.

3.3.1 Tape Dimensions

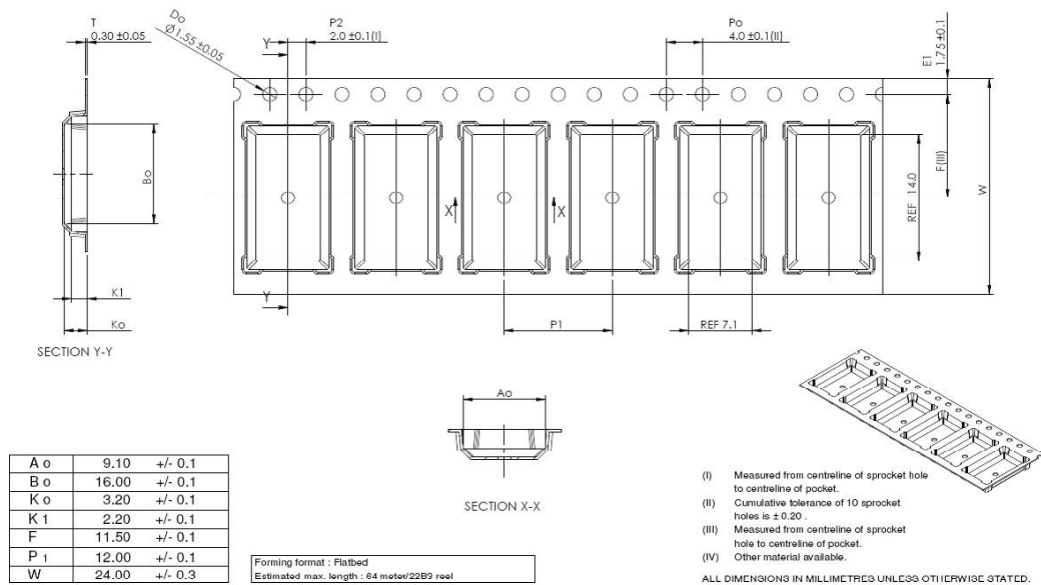

3.3.2 Packing in Tape

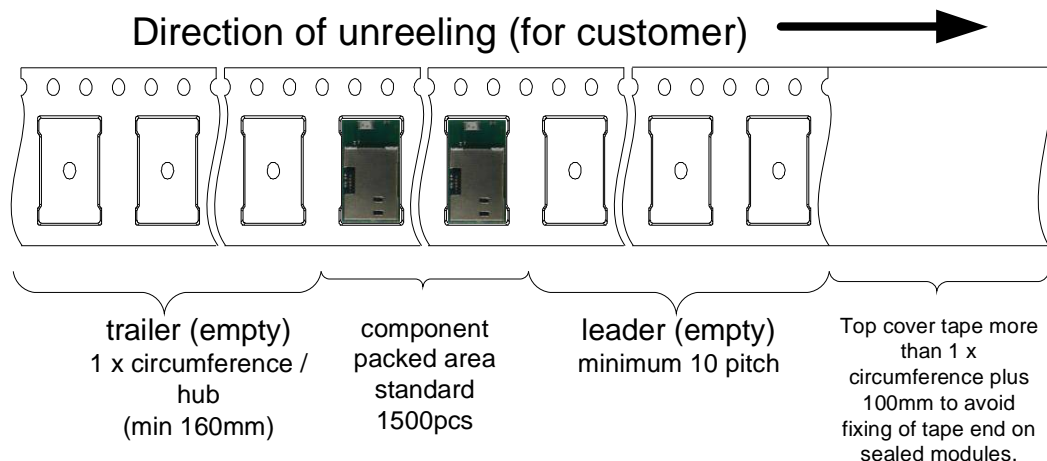

Empty spaces in the component packed area shall be less than two per reel and those spaces shall not be consecutive.

The top cover tape shall not be found on reel holes and it shall not stick out from the reel.

3.3.3 Component Direction

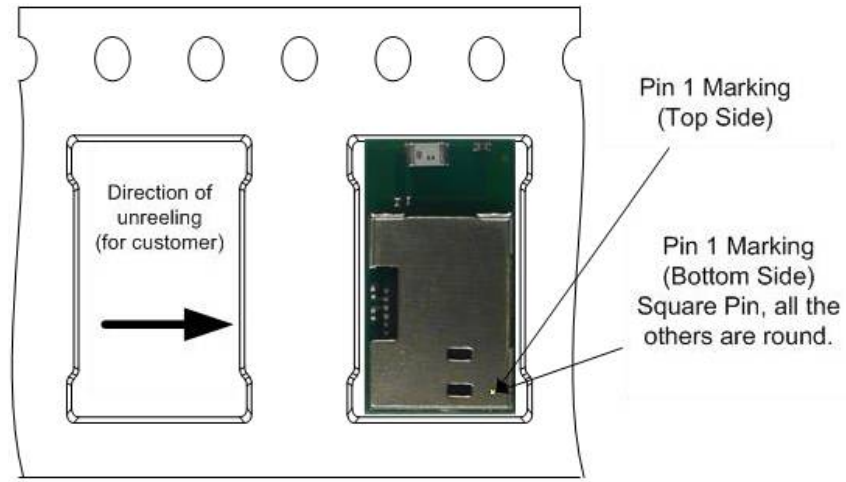

100730-PAN1720.vsd

3.3.4 Reel Dimension

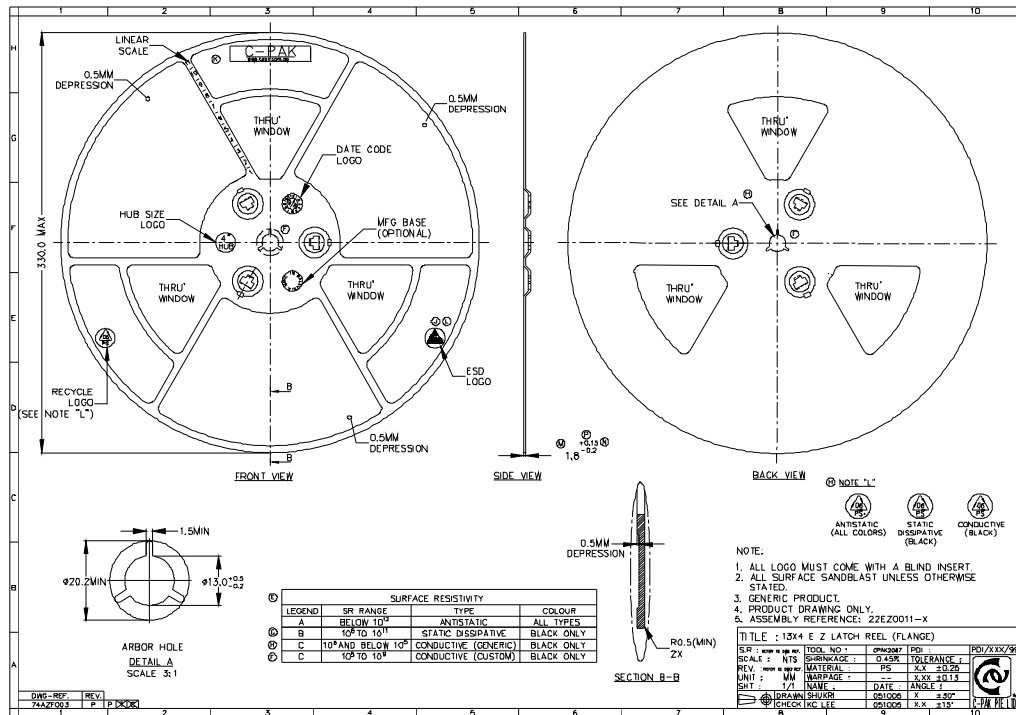

3.3.5 Package Label

Example



(1T)	Lot code
(1P)	Customer order number, if applicable
(2P)	Order number
(9D)	Date code
(Q)	Quantity
(HW/SW)	Hardware/software version

3.3.6 Total Package

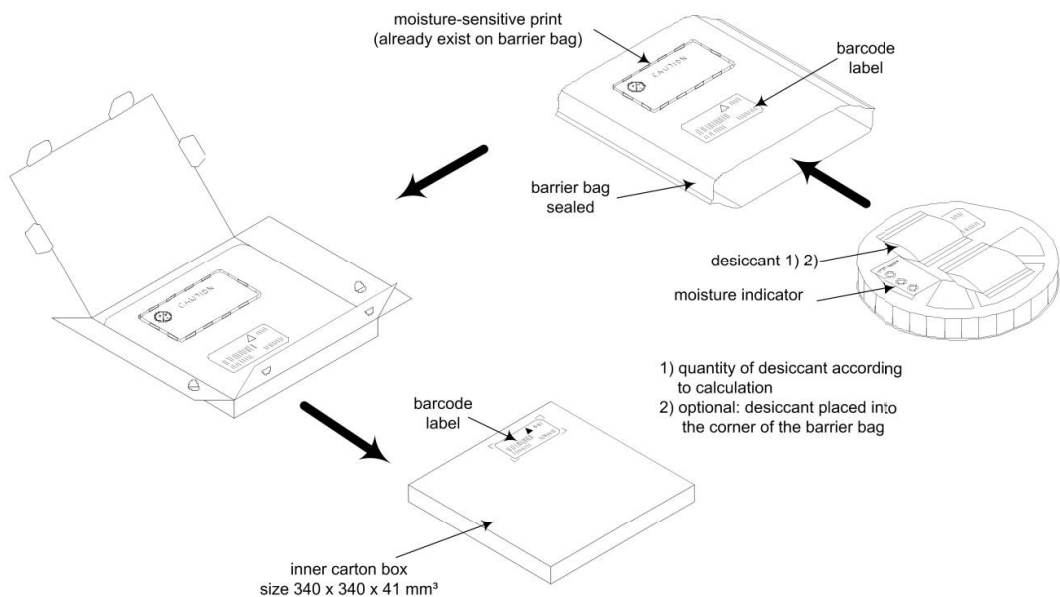

3.4 Case Marking

Example

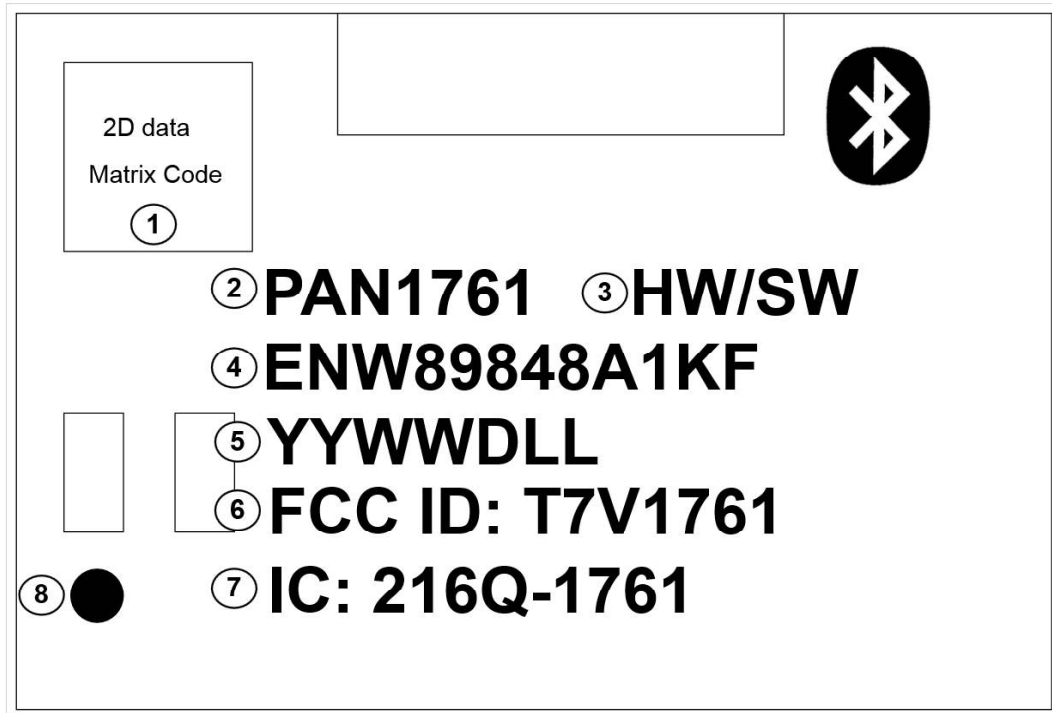

- 1 2D barcode, for internal usage only
- 2 Brand name
- 3 Hardware/software version
- 4 Order number
- 5 Lot code
- 6 FCC ID
- 7 IC ID
- 8 Marking for Pin 1

4 Specification



All specifications are over temperature and process, unless indicated otherwise.

4.1 Default Test Conditions



Temperature: 25 ± 10 °C
 Humidity: 40 to 85 % RH
 Supply Voltage: 3.3 V

4.2 Absolute Maximum Ratings



The maximum ratings may not be exceeded under any circumstances, not even momentarily or individually, as permanent damage to the module may result.

Parameter	Condition	Min.	Typ.	Max.	Units
Voltage on any digital pin		-0.3		VDD + 0.3	V
Operating ambient temperature range		-30		85	°C
Storage temperature range		-30		125	°C
Bluetooth RF inputs			10		dBm
ESD: All pads, according to human-body model, JEDEC STD 22, method A114 According to charged-device model, JEDEC STD 22, method C101			1000		V

4.3 Recommended Operating Conditions



The maximum ratings may not be exceeded under any circumstances, not even momentarily or individually, as permanent damage to the module may result.

Parameter	Condition	Min.	Typ.	Max.	Units
Power supply voltage		2.0	3.3	3.6	V
Maximum ambient operating temperature			-30	85	°C

4.4 Power Up Sequence

When the power is turned on, set reset signal to low (RESET=Low). After OSC is stable, release reset (RESET=High).

Crystal oscillator stabilizing time is about 2 msec, so define release time after sufficient evaluation.

When the power is turned off, set reset signal to low (RESET=Low).

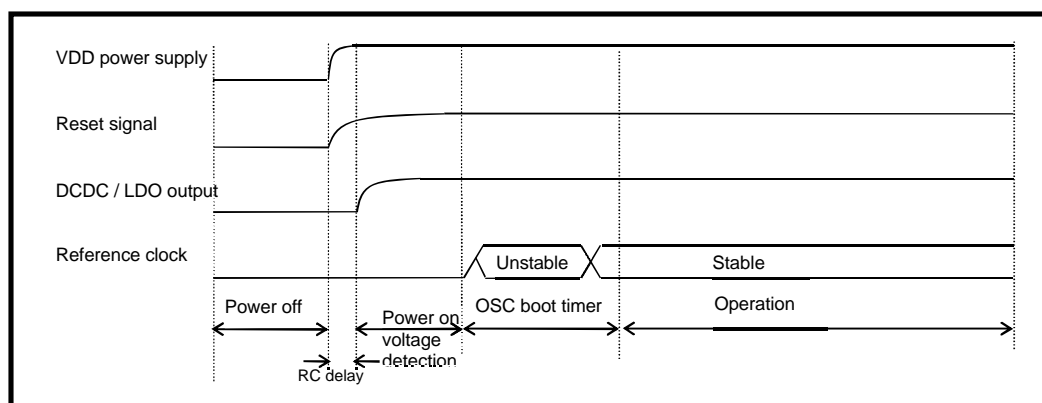

4.5 Current Consumption



The current consumption depends on the user scenario and on the setup and timing in the power modes.

Assume $V_{DD} = 3.3\text{ V}$, $T_{amb} = 25\text{ °C}$, if nothing else stated.

4.6 Bluetooth RF Performance

4.6.1 Bluetooth Characteristics

Parameter	Condition	Min.	Typ.	Max.	Units
Operation frequency range		2 402		2 480	MHz
Channel spacing			2		MHz
Output power	Maximum setting, measured at single ended 50 Ohm.		0		dBm
Sensitivity, High Gain mode	High-gain mode, measured at single ended 50 Ohm.		-90.0		dBm

4.6.2 NFC Tag Interface

PAN1761 has a built-in NFC Forum Type 3 Tag (NFC Tag) function.

Features of the PAN1761 NFC interface

- Built-in contactless IC card technology.
- Wireless interface: automatic detection of 212 kbps and 424 kbps transmission speed.
- I2C interface: maximum operational clock 400 kHz.
- Built-in EEPROM: general user area 1 520 bytes, protecting against defective data.
- Writing time: 5 ms (typ.), 1 bit error automatic correction, CRC automatic addition, and error detection of read data.
- Security: mutual authentication with Message Authentication Code (MAC), variety access attributes can be set. Writing prohibition, reading after authentication, writing after authentication, writing with MAC.

The technology refers to the following standards: JIS X 6319-4, ISO/IEC 18092

Basic technical characteristics

Item	Remarks
Data transmission format	Half duplex, synchronization
Carrier frequency	13.56 MHz
Data transmission speed	212,424 Kbit/s (automatic detection)
Modulation	ASK
Coding	Manchester
Bit order	MSBF

4.6.3 NFC Operational Sequence

If a wireless carrier is detected, TAG_RFDET pin outputs high level. If the wireless carrier disappears, TAG_RFDET pin turns back to low level due to pull-down resistance. Set VDDIO and VDD pin to output high (power supply). At Write without Encryption or Read without Encryption, if IDm stored in PAN1761 chip and iDm with command are consistent, TAG_READYX pin outputs high level. After that, during supply of internal power source, the high is kept. VDDIO and VDD pin need power supply for TAG_READYX pin to output high. By becoming high in TAG_READYX pin, HOST can get to know that wireless reader/writer accesses the module.

Sequence example of operation over the wireless TAG interface

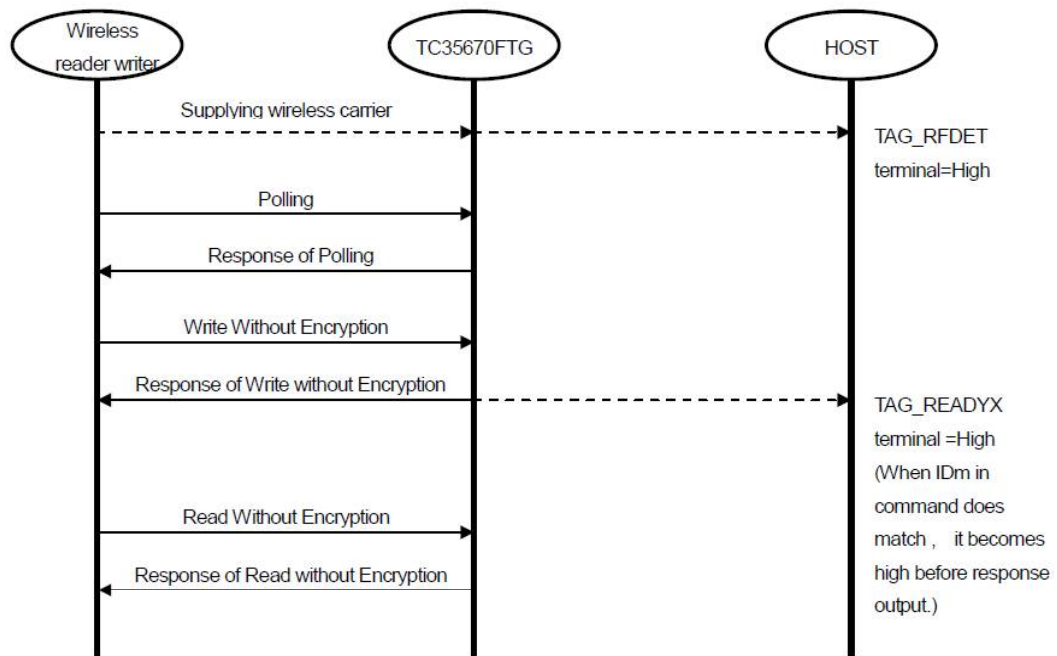

4.7 Antenna Radiation Pattern

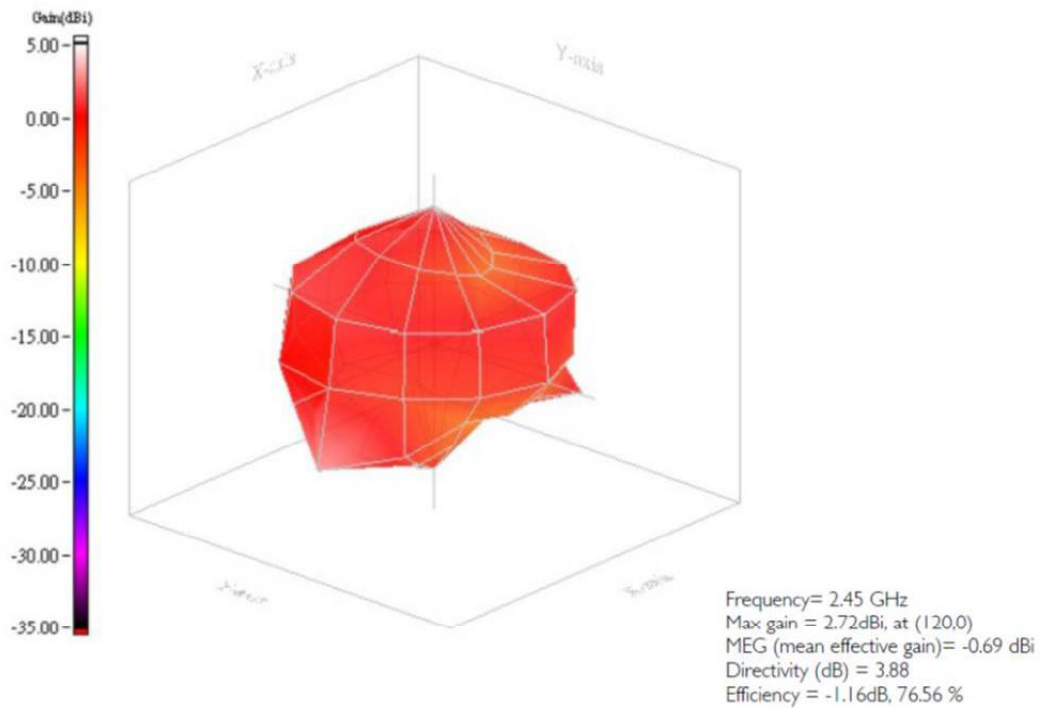
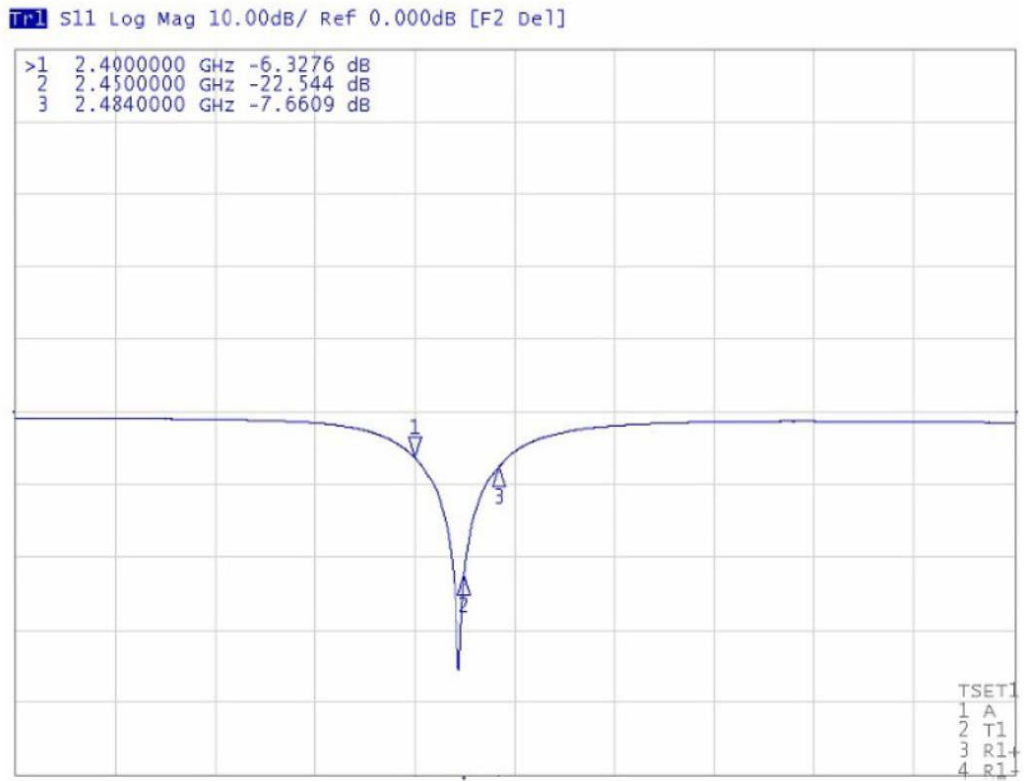

4.8 Reliability Tests

The measurement should be done after the test device has been exposed to room temperature and humidity for one hour.

No.	Item	Limit	Condition
1	Vibration test	Electrical parameter should be in specification	<ul style="list-style-type: none"> • Freq.: 10~50 Hz; Amplitude: 1.5 mm; 20 min./cycle, 1 hrs. each of XYZ axis • Freq.: 30~100 Hz, 6G; 20 min./cycle, 1 hrs. each of XYZ axis
2	Shock test	See above	Dropped onto hard wood from a height of 50 cm for 3 times
3	Heat cycle test	See above	-40 °C for 30 min. and +85 °C for 30 min.; each temperature 300 cycles
4	Moisture test	See above	+60 °C, 90 % RH, 300 h
5	Low temperature test	See above	-40 °C, 300 h
6	High temp. test	See above	+85 °C, 300 h

4.9 Recommended Soldering Profile



- Reflow permissible cycle: 2
- Opposite side reflow is prohibited due to module weight
- More than 75 percent of the soldering area shall be coated by solder
- The soldering profiles should be adhered to in order to prevent electrical or mechanical damage
- Soldering profile assumes lead-free soldering

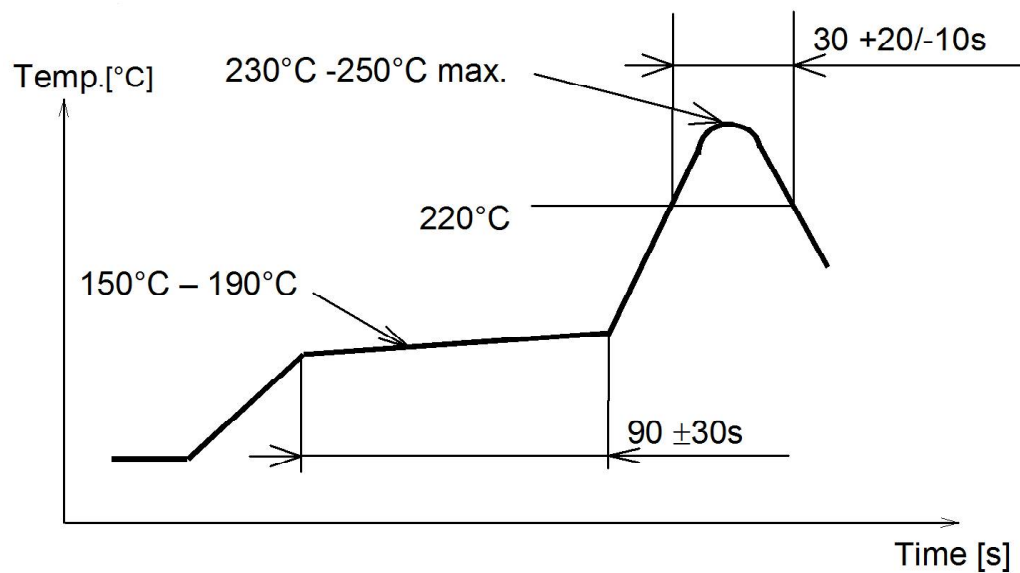

5 Cautions



Failure to follow the guidelines set forth in this document may result in degrading of the product's functions and damage to the product.

5.1 Design Notes

1. Follow the conditions written in this specification, especially the control signals of this module.
2. The supply voltage must be free of AC ripple voltage (for example from a battery or a low noise regulator output). For noisy supply voltages, provide a decoupling circuit (for example a ferrite in series connection and a bypass capacitor to ground of at least 47 μF directly at the module).
3. This product should not be mechanically stressed when installed.
4. Keep this product away from heat. Heat is the major cause of decreasing the life of these products.
5. Avoid assembly and use of the target equipment in conditions where the product's temperature may exceed the maximum tolerance.
6. The supply voltage should not be exceedingly high or reversed. It should not carry noise and/or spikes.
7. Keep this product away from other high frequency circuits.
8. Refer to the recommended pattern when designing a board.

5.2 Installation Notes

1. Reflow soldering is possible twice based on the conditions set forth in [⇨ 4.9 Recommended Soldering Profile](#). Set up the temperature at the soldering portion of this product according to this reflow profile.
2. Carefully position the products so that their heat will not burn into printed circuit boards or affect the other components that are susceptible to heat.
3. Carefully locate these products so that their temperatures will not increase due to the effects of heat generated by neighboring components.
4. If a vinyl-covered wire comes into contact with the products, then the cover will melt and generate toxic gas, damaging the insulation. Never allow contact between the cover and these products to occur.
5. This product should not be mechanically stressed or vibrated when reflowed.
6. To repair the board by hand soldering, follow the conditions set forth in this chapter.
7. Do not wash this product.
8. Pressing on parts of the metal cover or fastening objects to the metal will cause damage to the unit.

5.3 Usage Condition Notes

1. Take measures to protect the unit against static electricity.
If pulses or other transient loads (a large load applied in a short time) are applied to the products, check and evaluate their operation before assembly on the final products.
2. Do not use dropped products.
3. Do not touch, damage or soil the pins.
4. Follow the recommended condition ratings about the power supply applied to this product.
5. Electrode peeling strength: Do not add pressure of more than 4.9 N when soldered on PCB.
6. Pressing on parts of the metal cover or fastening objects to the metal cover will cause damage.
7. These products are intended for general purpose and standard use in general electronic equipment, such as home appliances, office equipment, information, and communication equipment.

5.4 Storage Notes

1. The module should not be stressed mechanically during storage.
2. Do not store these products in the following conditions or the performance characteristics of the product, such as RF performance will be adversely affected:
 - Storage in salty air or in an environment with a high concentration of corrosive gas, such as Cl₂, H₂S, NH₃, SO₂, or NO_x,
 - Storage in direct sunlight,
 - Storage in an environment where the temperature may be outside the range of 5 °C to 35 °C, or where the humidity may be outside the 45 to 85 percent range,
 - Storage of the products for more than one year after the date of delivery storage period: Please check the adhesive strength of the embossed tape and soldering after 6 months of storage.
3. Keep this product away from water, poisonous gas, and corrosive gas.
4. This product should not be stressed or shocked when transported.
5. Follow the specification when stacking packed crates (max. 10).

5.5 Safety Cautions

These specifications are intended to preserve the quality assurance of products and individual components.

Before use, check and evaluate the operation when mounted on your products. Abide by these specifications without deviation when using the products. These products may short-circuit. If electrical shocks, smoke, fire, and/or accidents involving human life are anticipated when a short circuit occurs, provide the following failsafe functions as a minimum:

1. Ensure the safety of the whole system by installing a protection circuit and a protection device.
2. Ensure the safety of the whole system by installing a redundant circuit or another system to prevent a single fault causing an unsafe status.

5.6 Other Cautions

1. Do not use the products for other purposes than those listed.
2. Be sure to provide an appropriate fail-safe function on your product to prevent any additional damage that may be caused by the abnormal function or the failure of the product.
3. This product has been manufactured without any ozone chemical controlled under the Montreal Protocol.
4. These products are not intended for uses other than under the special conditions shown below. Before using these products under such special conditions, carefully check their performance and reliability under the said special conditions to determine whether or not they can be used in such a manner:
 - In liquid, such as water, salt water, oil, alkali, or organic solvent, or in places where liquid may splash,
 - In direct sunlight, outdoors, or in a dusty environment,
 - In an environment where condensation occurs,
 - In an environment with a high concentration of harmful gas (e. g. salty air, HCl, Cl₂, SO₂, H₂S, NH₃, and NO_x).
5. If an abnormal voltage is applied due to a problem occurring in other components or circuits, replace these products with new products because they may not be able to provide normal performance even if their electronic characteristics and appearances appear satisfactory.
6. When you have any question or uncertainty, contact Panasonic.

5.7 Life Support Policy

This Panasonic Industrial Devices Europe GmbH product is not designed for use in life support appliances, devices, or systems where malfunction can reasonably be expected to result in a significant personal injury to the user, or as a critical component in any life support device or system whose failure to perform can be reasonably expected to cause the failure of the life support device or system, or to affect its safety or effectiveness.

Panasonic customers using or selling these products for use in such applications do so at their own risk and agree to fully indemnify Panasonic Industrial Devices Europe GmbH for any damages resulting.

6 Regulatory and Certification Information

6.1 RoHS and REACH Declaration

The latest declaration of environmental compatibility (Restriction of Hazardous Substances, RoHS and Registration, Evaluation, Authorisation, and Restriction of Chemicals, REACH) for supplied products can be found on the Panasonic website in the “Downloads” section of the respective product ⇒ [7.2.2 Product Information](#).

6.2 Federal Communications Commission (FCC) for US

6.2.1 FCC Notice



The PAN1761 including the antennas, which are listed in ⇒ [6.2.5 Approved Antenna List](#), complies with Part 15 of the FCC Rules.

The device meets the requirements for modular transmitter approval as detailed in FCC public Notice DA00-1407. The transmitter operation is subject to the following two conditions:

1. This device may not cause harmful interference, and
2. This device must accept any interference received, including interference that may cause undesired operation.

6.2.2 Caution



The FCC requires the user to be notified that any changes or modifications made to this device that are not expressly approved by Panasonic Industrial Devices Europe GmbH may void the user's authority to operate the equipment.



This equipment has been tested and found to comply with the limits for a Class B digital device, pursuant to Part 15 of the FCC Rules.

These limits are designed to provide reasonable protection against harmful interference in a residential installation. This equipment generates uses and can radiate radio frequency energy and, if not installed and used in accordance with the instructions, may cause harmful interference to radio communications.

However, there is no guarantee that interference will not occur in a particular installation. If this equipment does cause harmful interference to radio or television reception, which can be determined by turning the equipment off and on, the user is encouraged to try to correct the interference by one or more of the following measures:

- Reorient or relocate the receiving antenna.
- Increase the separation between the equipment and receiver.
- Connect the equipment into an outlet on a circuit different from that to which the receiver is connected.
- Consult the dealer or an experienced radio/TV technician for help

6.2.3 Label Requirements



The OEM must ensure that FCC labelling requirements are met. This includes a clearly visible label on the outside of the OEM enclosure specifying the appropriate Panasonic FCC identifier for this product as well as the FCC Notice above.

The FCC identifier is **FCC ID: T7V1761**.

This FCC identifier is valid for the PAN1761. The end product must in any case be labelled on the exterior with:

"Contains FCC ID: T7V1761"

6.2.4 Antenna Warning

This antenna warning refers to the test device with the model number PAN1761 → [Chapter 7.1 Ordering Information](#)

The device is tested with a standard SMA connector and with the antenna listed below. When integrated into the OEM's product, these fixed antennas require installation preventing end users from replacing them with non-approved antennas. Any antenna not in the following table must be tested to comply with FCC Section 15.203 for unique antenna connectors and with Section 15.247 for emissions. The FCC identifier for the device with the antenna listed in → [6.2.5 Approved Antenna List](#) is the same (**FCC ID: T7V1761**).

6.2.5 Approved Antenna List

Item	Part Number	Manufacturer	Frequency Band	Type	Gain (dBi)
1	LDA212G3110K	Murata	2.4 GHz	Chip antenna	+0.9
2	ANT2012	Yageo	2.4GHz	Chip-Antenna	+0.9

6.2.6 RF Exposure



To comply with FCC RF Exposure requirements, the OEM must ensure that only antennas from the Approved Antenna List are installed → [6.2.5 Approved Antenna List](#).

The preceding statement must be included as a CAUTION statement in manuals for products operating with the approved antennas in the previous table to alert users on FCC RF Exposure compliance.

Any notification to the end user of installation or removal instructions about the integrated radio module is not allowed.

The radiated output power of the PAN1761 with a mounted ceramic antenna (**FCC ID: T7V1761**) is below the FCC radio frequency exposure limits. Nevertheless, the PAN1761 shall be used in such a manner that the potential for human contact during normal operation is minimized.

End users may not be provided with the module installation instructions. OEM integrators and end users must be provided with transmitter operating conditions for satisfying RF exposure compliance.

6.3 Industry Canada Certification

English

The PAN1761 is licensed to meet the regulatory requirements of Industry Canada (IC).

License ID: **IC: 216Q-1761**

Manufacturers of mobile, fixed or portable devices incorporating this module are advised to clarify any regulatory questions and ensure compliance for SAR and/or RF exposure limits. Users can obtain Canadian information on RF exposure and compliance from www.ic.gc.ca.

This device has been designed to operate with the antennas listed in → [6.2.5 Approved Antenna List](#), having a maximum gain of +0.9 dBi. Antennas not included in this list or having a gain greater than +0.9 dBi are strictly prohibited for use with this device. The required antenna impedance is 50 ohms. The antenna used for this transmitter must not be co-located or operating in conjunction with any other antenna or transmitter.

Due to the model size, the IC identifier is displayed in the installation instruction only and it cannot be displayed on the module's label due to the limited size.

French

PAN1761 est garanti conforme aux dispositions réglementaires d'Industry Canada (IC).

License: **IC: 216Q-1761**

Il est recommandé aux fabricants d'appareils fixes, mobiles ou portables de consulter la réglementation en vigueur et de vérifier la conformité de leurs produits relativement aux limites d'exposition aux rayonnements radiofréquence ainsi qu'au débit d'absorption spécifique maximum autorisé.

Des informations pour les utilisateurs sur la réglementation Canadienne concernant l'exposition aux rayonnements RF sont disponibles sur le site www.ic.gc.ca.

Ce produit a été développé pour fonctionner spécifiquement avec les antennes listées dans le tableau ⇒ [6.2.5 Approved Antenna List](#), présentant un gain maximum de 0.9 dBi. Des antennes autres que celles listées ici, ou présentant un gain supérieur à 0.9 dBi ne doivent en aucune circonstance être utilisées en combinaison avec ce produit. L'impédance des antennes compatibles est 50 Ohm. L'antenne utilisée avec ce produit ne doit ni être située à proximité d'une autre antenne ou d'un autre émetteur, ni être utilisée conjointement avec une autre antenne ou un autre émetteur.

En raison de la taille du produit, l'identifiant IC est fourni dans le manuel d'installation.

6.3.1 IC Notice**English**

The device PAN1761 (⇒ [7.1 Ordering Information](#)), including the antennas (⇒ [6.2.5 Approved Antenna List](#)), complies with Canada RSS-GEN Rules. The device meets the requirements for modular transmitter approval as detailed in RSS-Gen.

Operation is subject to the following two conditions:

1. This device may not cause harmful interference, and
2. This device must accept any interference received, including interference that may cause undesired operation.

French

Le présent appareil PAN1761 (⇒ [7.1 Ordering Information](#)), les antennes y compris (⇒ [6.2.5 Approved Antenna List](#)), est conforme aux CNR-Gen d'Industrie Canada applicables aux appareils radio exempts de licence.

L'exploitation est autorisée aux deux conditions suivantes :

1. l'appareil ne doit pas produire de brouillage, et
2. l'utilisateur de l'appareil doit accepter tout brouillage radioélectrique subi, même si le brouillage est susceptible d'en compromettre le fonctionnement.

6.3.2 Labeling Requirements

English



Labeling Requirements

The OEM must ensure that IC labelling requirements are met. This includes a clearly visible label on the outside of the OEM enclosure specifying the appropriate Panasonic IC identifier for this product as well as the IC Notice above.

The IC identifier is:

IC: 216Q-1761

This IC identifier is valid for all PAN1761 modules ⇒ [7.1 Ordering Information](#). In any case, the end product must be labelled on the exterior with:

"Contains IC: 216Q-1761".

French



Obligations d'étiquetage

Les fabricants d'équipements d'origine (FEO) – en anglais Original Equipment Manufacturer (OEM) – doivent s'assurer que les obligations d'étiquetage IC du produit final sont remplies. Ces obligations incluent une étiquette clairement visible à l'extérieur de l'emballage externe, comportant l'identifiant IC du module Panasonic inclus, ainsi que la notification ci-dessus.

L'identifiant IC est:

IC: 216Q-1761

Cet identifiant est valide pour tous les modules PAN1761 ⇒ [7.1 Ordering Information](#). Dans tous les cas les produits finaux doivent indiquer sur leur emballage externe la mention suivante:

"Contient IC: 216Q-1761".

6.4 European Conformity According to RED (2014/53/EU)

All modules described in this Product Specification comply with the standards according to the following LVD (2014/35/EU), EMC-D (2014/30/EU) together with the RED (2014/53/EU) articles:

3.1a Safety/Health:	EN62368-1:2014 EN62311:2008
3.1b EMC:	EN 301 489-1 V2.1.1:2017-02 EN 301 489-17 V3.1.1:2017-02
3.2 Radio:	EN 300 328 V2.1.1:2016-11

As a result of the conformity assessment procedure described in the 2014/53/EU Directive, the end customer equipment should be labelled as follows:



PAN1761 in the specified reference design can be used in all countries of the European Economic Area (Member States of the EU, European Free Trade Association States [Iceland, Liechtenstein, Norway]), Monaco, San Marino, Andorra and Turkey.

7 Appendix

7.1 Ordering Information

Variants and Versions

Order Number	Brand Name	Description	MOQ ¹
ENW89848A1KF ²	PAN1761	PAN1761 Bluetooth Low Energy & NFC Combo Module	1 500

¹ Abbreviation for Minimum Order Quantity (MOQ). The default MOQ for mass production is 1 500 pieces, fewer only on customer demand. Samples for evaluation can be delivered at any quantity via the distribution channels.

² Samples are available on customer demand.

7.2 Contact Details

7.2.1 Contact Us

Please contact your local Panasonic Sales office for details on additional product options and services:

For Panasonic Sales assistance in the **EU**, visit

<https://eu.industrial.panasonic.com/about-us/contact-us>

Email: wireless@eu.panasonic.com

For Panasonic Sales assistance in **North America**, visit the Panasonic Sales & Support Tool to find assistance near you at

<https://na.industrial.panasonic.com/distributors>

Please visit the **Panasonic Wireless Technical Forum** to submit a question at

<https://forum.na.industrial.panasonic.com>

7.2.2 Product Information

Please refer to the Panasonic Wireless Connectivity website for further information on our products and related documents:

For complete Panasonic product details in the **EU**, visit

<http://pideu.panasonic.de/products/wireless-modules.html>

For complete Panasonic product details in **North America**, visit

<http://www.panasonic.com/rfmodules>

Panasonic NRFND.PG15.2.18.2020 Affected Parts

NRFND		Recommended Replacements	
PAN1761	ENW-89848A1KF	PAN1780	ENW-89854A1KF
PAN1761 Kit	ENW89848AVKF	PAN1780 Kit	ENW89854AWKF